

MAX

PHOTONICS

Fiber Laser Cutting & Welding Source



SUPER SONIC

SUPER SONIC HOUSE, Plot No. C-10/5-6, Soma Kanji Estate-2, (SK-2),
Near Sosyo Circle, Opp. Sanidev Temple, Udhna Magdalla Road,
Surat (Gujarat) India - 395007 | www.supersonicgroup.in
For Enquiry Contact : +91 261 2634263, 95128 51510
e-mail : supersonichouse02@hotmail.com

MFSC

1000X~1500X

Single Module CW Fiber Laser



Product Feature



Up to 12KW Output From CW Single Module Series

Better beam quality vs. multi module lasers
Greatly improved efficiency



Excellent Material Processing Performance

High speed in thin sheet cutting
Strong capability in thick material processing



Compact Design, Maintenance Free

Highly integrated system with modular design
Easy maintenance significantly reduce TCO



Smaller Size with Higher Stability

>60% reduction in volume
Higher flexibility when integrated in to system



High Level Vertical Integration

All key components are designed and produced in house
Strict quality control, high consistency and reliability

MAX PHOTONICS

MFSC 1000X~1500X Fiber Laser Specifications

Models	MFSC-1000X	MFSC-1500X
OPTICAL SPECIFICATIONS		
Nominal Power	1000W	1500W
Mode of Operation	CW/Modulated	
Polarization	Random	
Power Tunability	10 to 100%	
Wavelength	1080 ± 10 nm	
Power Stability(1h)	±1 %	
Laser Beam Quality, BPP	1.0 to 2.0 mm x mrad(50um QBH)	
	3.0 to 4.0 mm x mrad(100um QBH)	
Modulation Frequency	≤ 20kHz	
Red Guide Laser Power	200-1000 μW (Class 2)	
FIBER DELIVERY SYSTEM		
Interface	QBH(LOC)	
Length	15m standard, other lengths optional	
Diameter	50 (25) μm	50 (35) μm
Bending Radius	min.150mm	
ELECTRICAL RATINGS		
Supply Voltage	220VAC (-15% to +10%) Single-phase	
OTHER SPECIFICATIONS		
Operating Temperature	+10 to +40°C	
Storage Temperature	-10 to +60°C	
Humidity	10 to 85%	
Cooling Method	Water Cooling	
Cooling Medium	Distilled water/ Glycol Antifreeze	
Dimension	482.6*550*133 (W*D*H)	
Weight	32(±2)kg	36(±2) kg

Mechanical Specifications (mm)

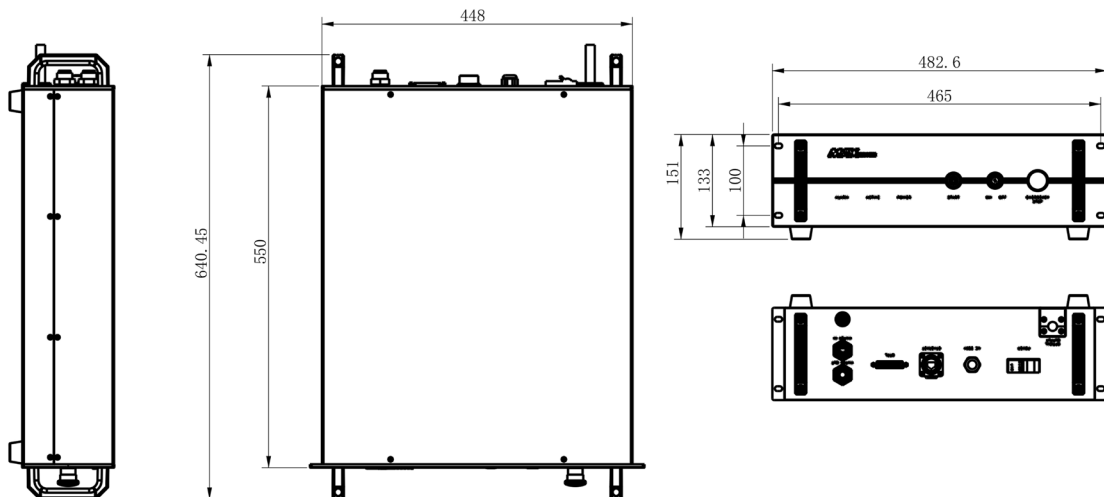

Maxphotonics Co.,Ltd.

Address: Maxphotonics Industrial Park, 3rd Furong Road,
Furong Industrial Area, Shajing, Bao'an, Shenzhen, China.518125
E-Mail: sales@maxphotonics.com <http://en.maxphotonics.com>

MAX PHOTONICS

MFSC 2000X

Single Module CW Fiber Laser



Product Feature



Up to 12KW Output From CW Single Module Series

Better beam quality vs. multi module lasers
Greatly improved efficiency



Excellent Material Processing Performance

High speed in thin sheet cutting
Strong capability in thick material processing



Compact Design, Maintenance Free

Highly integrated system with modular design
Easy maintenance significantly reduce TCO



Smaller Size with Higher Stability

>60% reduction in volume
Higher flexibility when integrated in to system



High Level Vertical Integration

All key components are designed and produced in house
Strict quality control, high consistency and reliability

MAX PHOTONICS

MFSC 2000X Fiber Laser Specifications

Models	MFSC-2000X
OPTICAL SPECIFICATIONS	
Nominal Power	2000W
Mode of Operation	CW/Modulated
Polarization	Random
Power Tunability	10 to 100 %
Wavelength	1080 ± 10 nm
Power Stability(1h)	±1 %
Laser Beam Quality, BPP	1.0 to 2.0 mm x mrad(50um QBH)
	< 1 mm x mrad(30um QBH)
Modulation Frequency	≤ 5 kHz
Red Guide Laser Power	200-1000 μW (Class 2)
FIBER DELIVERY SYSTEM	
Interface	QBH (LOC)
Length	15 m standard, other lengths optional
Diameter	50(100/200) μm
Bending Radius	min.150mm
ELECTRICAL RATINGS	
Supply Voltage	220VAC (-15% to +10%) 3-phase
OTHER SPECIFICATIONS	
Operating Temperature	+10 to +40 °C
Storage Temperature	-10 to +60 °C
Humidity	10 to 85 %
Cooling Method	Water Cooling
Cooling Medium	Distilled water/ Glycol Antifreeze
Dimension	482.6*550*133 (W*D*H)
Weight	42(±2) kg

Mechanical Specifications (mm)

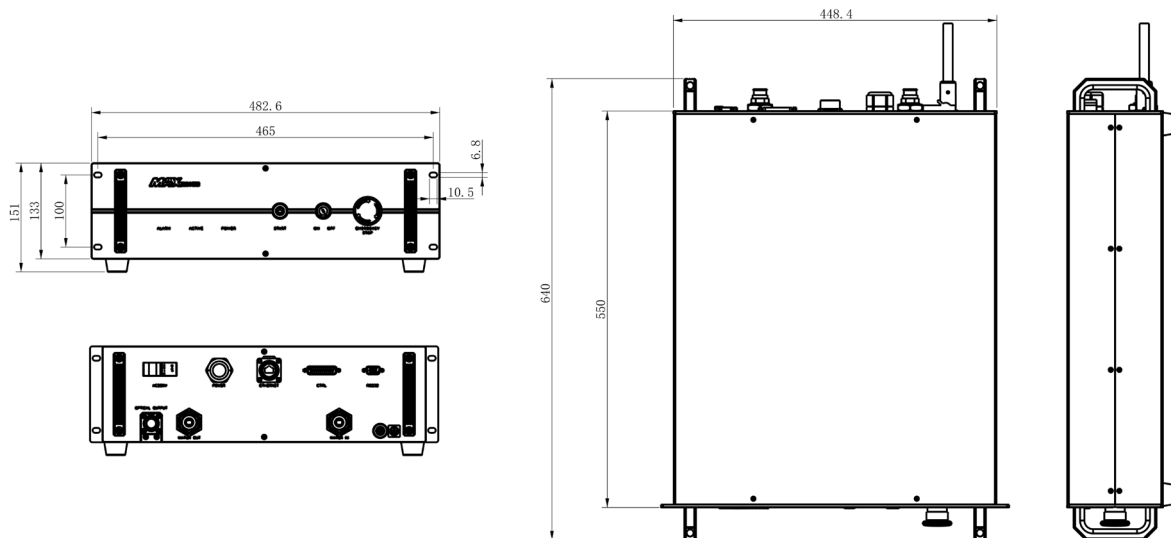

Maxphotonics Co., Ltd.

Address: Maxphotonics Industrial Park, 3rd Furong Road,
Furong Industrial Area, Shajing, Bao'an, Shenzhen, China.518125
E-Mail: sales@maxphotonics.com <http://en.maxphotonics.com>

MAX PHOTONICS

MFSC

3000X~4000X

Single Module CW Fiber Laser



Product Feature



Up to 12KW Output From CW Single Module Series

Better beam quality vs. multi module lasers
Greatly improved efficiency



Excellent Material Processing Performance

High speed in thin sheet cutting
Strong capability in thick material processing



Compact Design, Maintenance Free

Highly integrated system with modular design
Easy maintenance significantly reduce TCO



Smaller Size with Higher Stability

>60% reduction in volume
Higher flexibility when integrated in to system



High Level Vertical Integration

All key components are designed and produced in house
Strict quality control, high consistency and reliability

MAX PHOTONICS

MFSC 3000X~4000X Fiber Laser Specifications

Models	MFSC-3000X	MFSC-4000X
OPTICAL SPECIFICATIONS		
Nominal Power	3000W	4000W
Mode of Operation	CW/Modulated	
Polarization	Random	
Power Tunability	10 to 100 %	
Wavelength	1080 ± 10 nm	
Power Stability(1h)	±1 %	
Laser Beam Quality, BPP	1.0 to 2.0 mm x mrad(50um QBH)	
	3.0 to 4.0 mm x mrad(100um QBH)	
Modulation Frequency	≤ 5 kHz	
Red Guide Laser Power	200-1000 μW (Class 2)	
FIBER DELIVERY SYSTEM		
Interface	QBH (LOC)	
Length	20 m standard, other lengths optional	
Diameter	50(100/200) μm	
Bending Radius	min.150mm	
ELECTRICAL RATINGS		
Supply Voltage	400VAC (-15% to +10%) 3-phase	
OTHER SPECIFICATIONS		
Operating Temperature	+10 to +40 °C	
Storage Temperature	-10 to +60 °C	
Humidity	10 to 85 %	
Cooling Method	Water Cooling	
Cooling Medium	Distilled water/ Glycol Antifreeze	
Dimension	482.6*850*172 (W*D*H)	
Weight	70(±3) kg	80(±3) kg

Mechanical Specifications (mm)

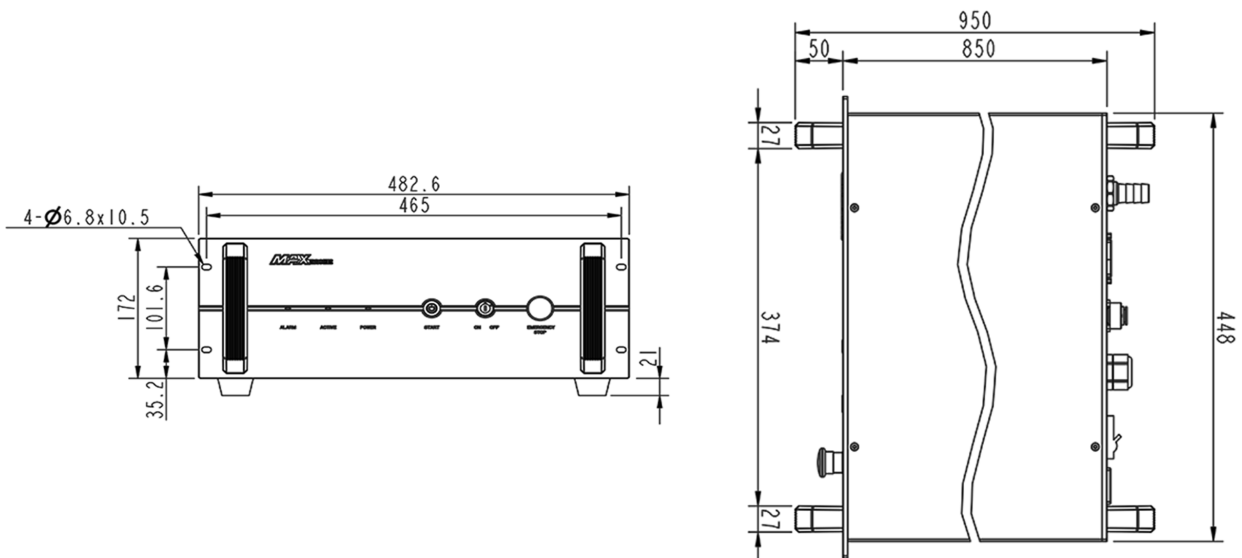

Maxphotonics Co.,Ltd.

Address: Maxphotonics Industrial Park, 3rd Furong Road,
Furong Industrial Area, Shajing, Bao'an, Shenzhen, China.518125
E-Mail: sales@maxphotonics.com <http://en.maxphotonics.com>

MAX PHOTONICS

MFSC

6000M(G4)

Single-Module CW Fiber Laser



PRODUCT FEATURE



High Power with Great Beam Quality

High power density with flat-head distribution
High wall-plug efficiency



Even Energy Distribution

Less splash during cutting and welding



Excellent Material Processing Performance

High speed in thin sheet cutting
Strong capability in thick material processing



Compact Design, Maintenance Free

Highly integrated system with modular design
High stability and easy maintenance significantly reduce TCO



Best Choice for Cutting and Welding

Widely used in hardware processing, automobile, shipping, construction machinery, medical industries and more.



QBH

MAX PHOTONICS

MFSC 6000M SINGLE MODULE CW FIBER LASER SPECIFICATIONS

Model	MFSC-6000M
OPTICAL SPECIFICATIONS	
Nominal Power	6000W
Mode of Operation	CW/Modulated
Polarization	Random
BPP(mm x mrad)	3.0-4.0(@100um Fiber Core)
Wavelength(nm)	1080 ± 10
Spectrum Width(3dB)(nm)	4 to 7
Power Tunability(%)	10 to 100
Power Instability(%): 1h	± 1
Modulation Frequency(kHz)	≤ 5
Red Guide Laser Power(μW)	min. 200
FIBER DELIVERY SYSTEM	
Interface	QBH(LOC)
Length(m)	20
Diameter(μm)	100, 150 or 200
Bending Radius(mm)	≥ 200
ELECTRICAL RATINGS	
Supply Voltage(VAC)	360-440 VAC 3-phase 50/60Hz
OTHER SPECIFICATIONS	
Operating Temperature(°C)	10 to 40
Storage Temperature(°C)	-10 to 60
Humidity(%)	10 to 80
Cooling Method(°C)	Water-cooling
Cooling Medium	Pure water (above 0° C)/Glycol antifreeze (below 0° C)
Dimension(mm)	400*900*550(excluding casters/warning lights, etc.)
Weight(kg)	147 ± 5

MECHANICAL SPECIFICATIONS (mm)

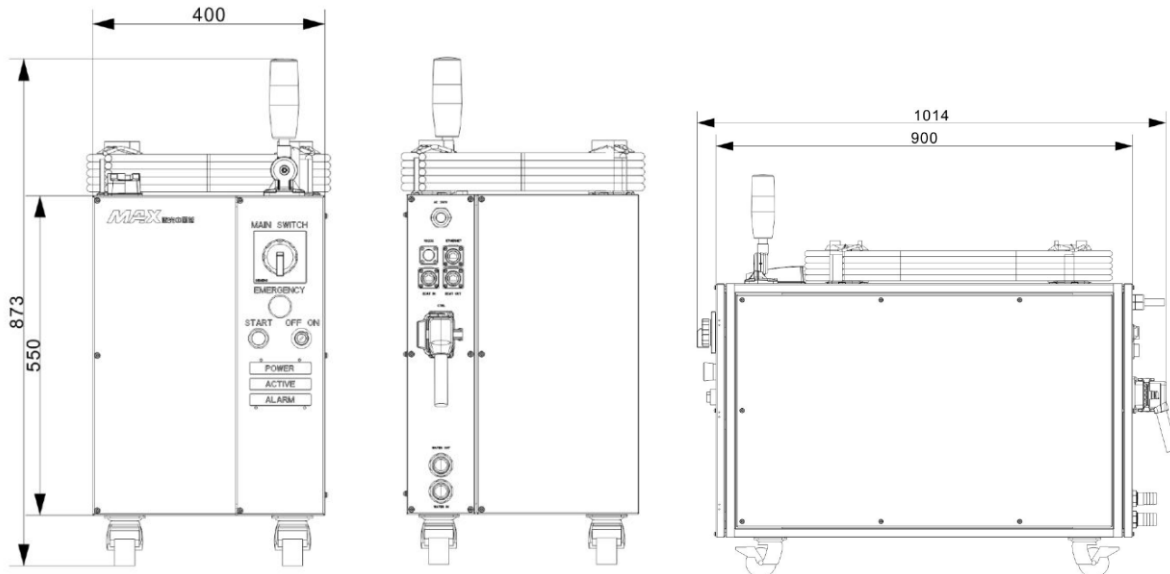

Maxphotonics Co.,Ltd.

Address: Maxphotonics Industrial Park, 3rd Furong Road,
Furong Industrial Area, Shajing, Bao'an, Shenzhen, China.518125 E-
Mail: sales@maxphotonics.com <http://en.maxphotonics.com>

MAX PHOTONICS

The picture and the technical parameter are just for your reference. Please be subject to the actual products if anything different or updated.

MFSC

12000M

Single Module CW Fiber Laser



PRODUCT FEATURE



High Power with Great Beam Quality

High power density with flat-head distribution
High wall-plug efficiency



Even Energy Distribution

Less splash during cutting and welding



Excellent Material Processing Performance

High speed in thin sheet cutting
Strong capability in thick material processing



Compact Design, Maintenance Free

Highly integrated system with modular design
High stability and easy maintenance significantly reduce TCO



Best Choice for Cutting and Welding

Widely used in hardware processing, automobile, shipping, construction machinery, medical industries and more.



LOE

MFSC 12000M SINGLE MODULE CW FIBER LASER SPECIFICATIONS

Model	MFSC-12000M
OPTICAL SPECIFICATIONS	
Nominal Power	12000W
Mode of Operation	CW/Modulated
Polarization	Random
BPP(mm x mrad)	3.0-4.0 (@100um fiber core)
Wavelength(nm)	1080 ± 10
Spectrum Width(3dB)(nm)	5 to 7
Power Tunability(%)	10 to 100
Power Instability(%): 1 hr	± 1
Modulation Frequency(kHz)	≤ 5
Red Guide Laser Power(μW)	min. 200
FIBER DELIVERY SYSTEM	
Interface	LOE
Length(m)	25
Diameter(μm)	50, 100, 150 or 200
Bending Radius(mm)	≥ 200
ELECTRICAL RATINGS	
Supply Voltage(VAC)	360-440 VAC 3-phase 50/60Hz
OTHER SPECIFICATIONS	
Operating Temperature(°C)	10 to 40
Storage Temperature(°C)	-10 to 60
Humidity(%)	10 to 80
Cooling Method(°C)	Water-cooling
Cooling Medium	Pure water (above 0° C)/Glycol antifreeze (below 0° C)
Dimension(mm)	480*950*780(excluding casters/warning lights, etc.)
Weight(kg)	290 ± 10

MECHANICAL SPECIFICATIONS (mm)

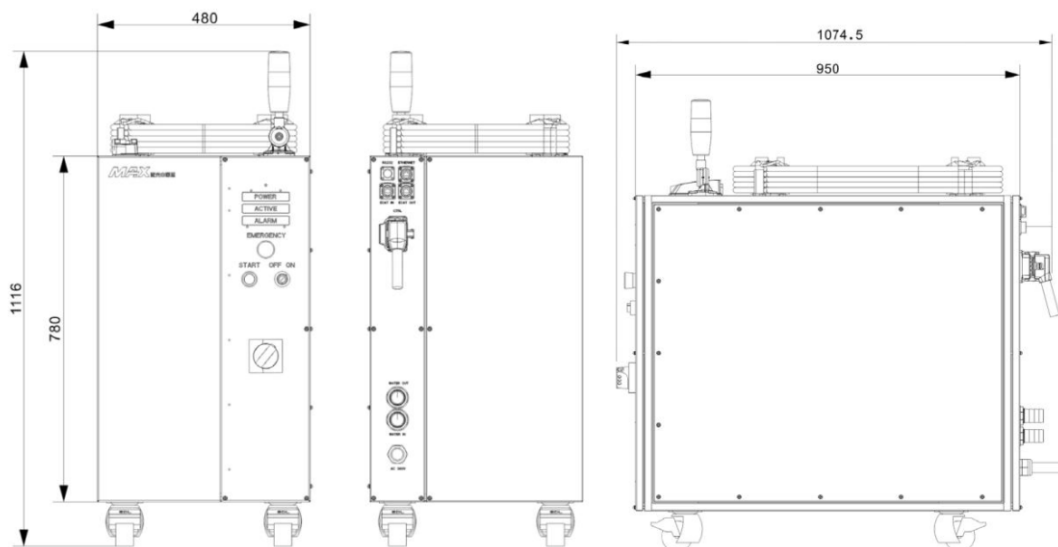

Maxphotonics Co.,Ltd.

Address: Maxphotonics Industrial Park, 3rd Furong Road,
Furong Industrial Area, Shajing, Bao'an, Shenzhen, China.518125
E-Mail: sales@maxphotonics.com <http://en.maxphotonics.com>

MAX PHOTONICS

The picture and the technical parameter are just for your reference. Please be subject to the actual products if anything different or updated.