

GROWING TOGETHER

MIMY

High Precision planetary Reducers



SUPER SONIC HOUSE, Plot No. C-10/5-6, Soma Kanji Estate-2, (SK-2),
Near Sosyo Circle, Opp. Sanidev Temple, Udhna Magdalla Road,
Surat (Gujarat) India - 395007 | www.supersonicgroup.in
For Enquiry Contact : +91 261 2634263, 95124 51510
e-mail : supersonichouse06@gmail.com

目录 CONTENTS

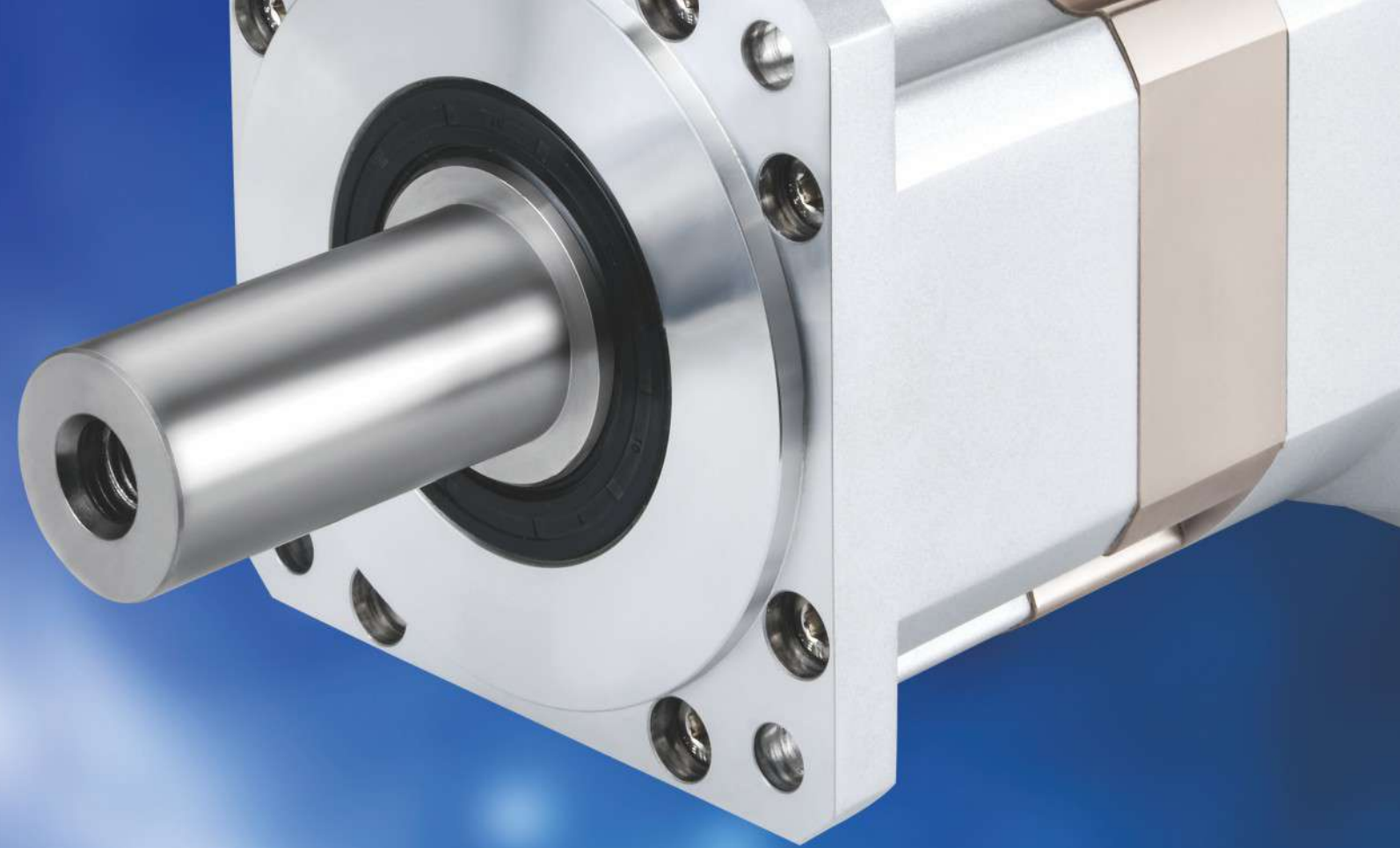

PLF
Page 13



PLE
Page 23



PLEK
Page 69



VLF
Page 77



PLFS
Page 79



ZPLF
Page 33



ZPLE
Page 41



PLFK
Page 56



PLS
Page 86



PLX
Page 93



ZPT
Page 108

Product features

产品特点

精密行星齿轮减速机是我公司自主研发的新一代实用性产品，具有以下一些主要特点

Precision planetary gear reducer is a new generation of practical products independently developed by our company, which has the following main characteristics



低噪音
Low noise
低于65db。
below 65db.



高输入转速
High input speed
可达5000RPM。
Up to 5000RPM.



低间隙
Low Backlash
单级可达3弧分内，双级可达5弧分内。
One stage within 3 arc minutes, Two stage with 5 arcmin.



高扭矩
High torque
比一般行星减速机扭矩高。
Higher than conventional planetary gearbox.



高效率
High efficiency
单段式在97%以上，双段式在95%以上。
One stage is exceed 97%, Two stage is exceed 95%.



高稳定性
High stability
采用高强度合金钢材，整个齿轮经硬化处理，非只有表面硬化，确保使用寿命及长期使用仍保持最初的精密度。
Using high-strength steel alloy material .Not just hardening on gear surface, but hardening entire gear to insure the gear life time and maintain high accuracy.

Product application

产品用途

精密行星齿轮减速机被广泛应用于以下领域
Precision planetary gear reducer is widely used in the following fields

- 01 航空航天、军事产业。
Aerospace, military industries.
- 02 医疗卫生、电子信息技术产业。
Medical health care, electronic information technology industry.
- 03 工业机器人、生产自动化、数控机床制造产业。
Industrial robot, production automation, CNC machine tool manufacturing industry.
- 04 汽车制造、纺织、印刷、食品、冶金、环保工程、仓储物流等产业。
Motor, textile, printing, food, metallurgical, environmental protection engineering, warehouse and logistics industry.

Description Reducer

减速机订货说明

减速机型号说明

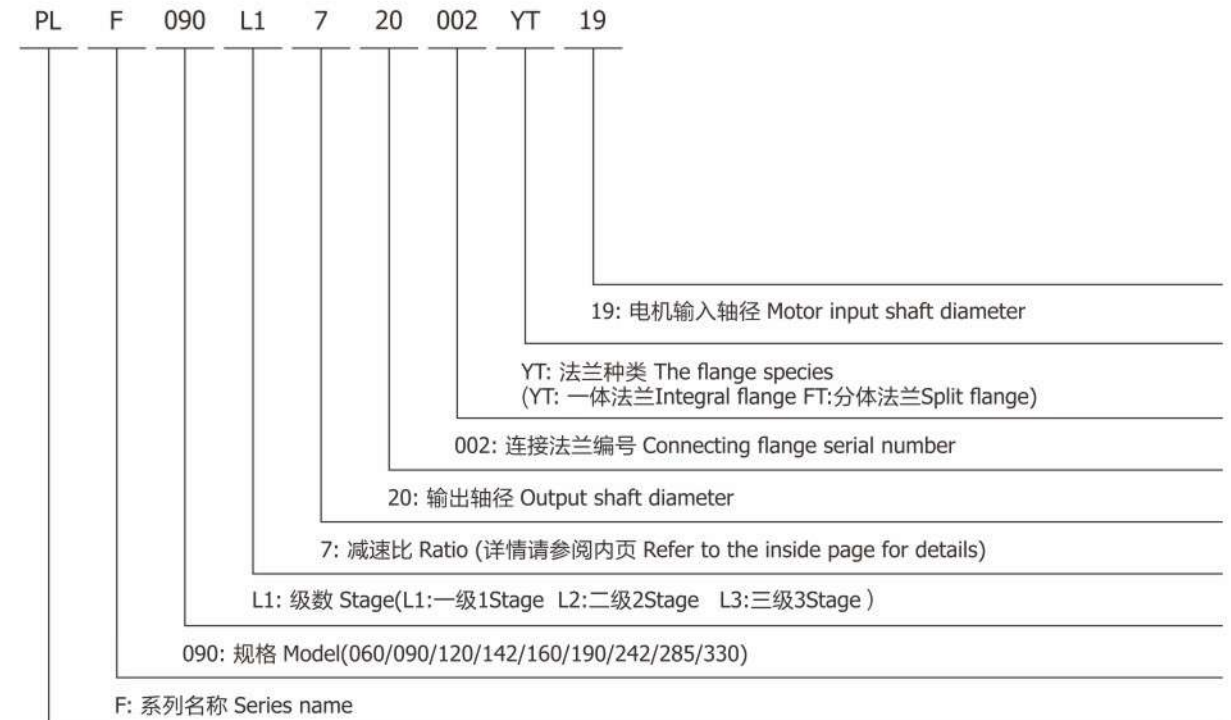

PL: PL减速机的名称 Model name for PL reducer

电机输出安装尺寸说明

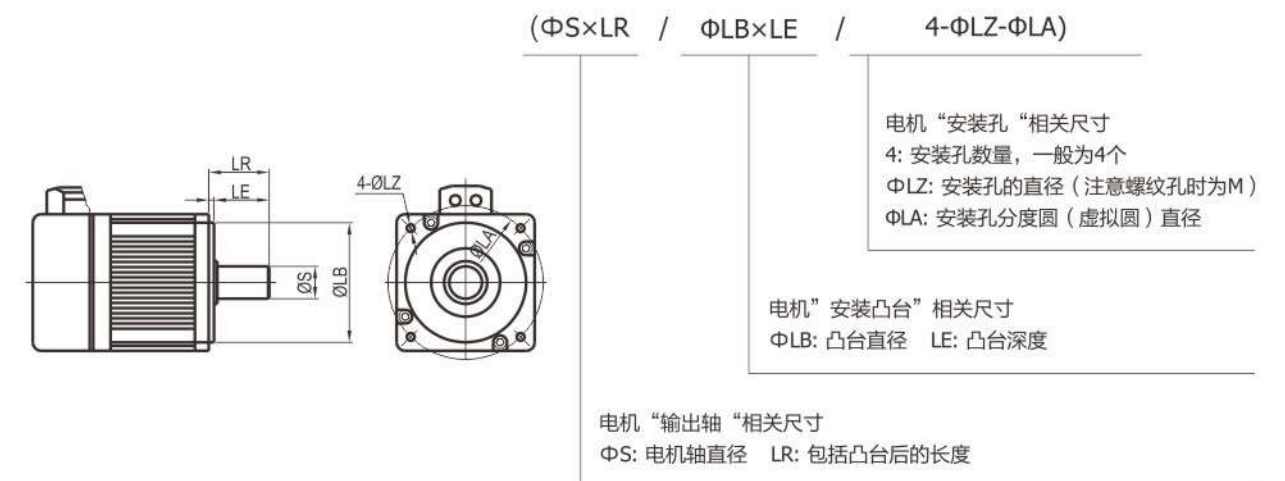

- ✓ PLF060
- ✓ PLF080
- ✓ PLF090
- ✓ PLF120
- ✓ PLF160

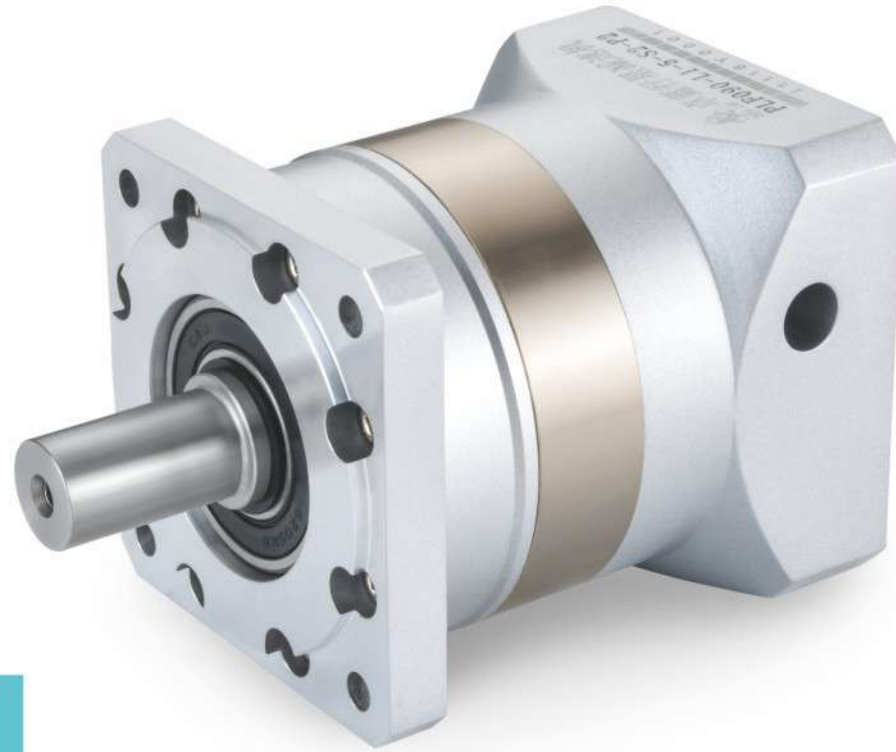

PLF Series

PLF系列减速机核心特性

The Core Characteristics of PLF Series Reducer

- 1 采用直齿齿轮传动，经渗碳淬火处理，齿向齿廓修形处理，确保运行平稳，噪音小；
- 2 结构简单，可大批量生产，且交货期快性价比高；
- 3 减速机种类齐全，可以满足市场上绝大多数减速机的配合。

- 1 Adopt straight tooth gear transmission, through carburizing and quenching treatment, tooth profile modification treatment, ensure smooth operation, low noise.
- 2 Simple structure, mass production, and fast delivery time and high cost performance.
- 3 Reducer has a complete range, which can meet the needs of most reducer in the market.

减速机性能资料

Gear box performance information

型号 Model	单位 Unit	PLF060	PLF080	PLF090	PLF120	PLF160	减速比 Ratio	Stage
额定输出扭矩 Rated output torque	N·m	16.5	60	60	148	310	3	1
		27	86	86	222	605	4	
		27	94.5	94.5	235	420	5	
		19.5	64	64	158	(270)	7(8)	
		8.5	39.5	39.5	93	-	10	
			96	96	250	680	12	
			96	96	250	-	15	2
		30	96	96	250	680	16	
		30	96	96	250	680	20	
		33	105.5	105.5	264	460	25	
		30	96	96	250	(680)	28(32)	
		33	105.5	105.5	264	-	35	
		30	96	96	250	460	40	3
		33	105.5	105.5	264	(310)	50(64)	
		21.5	71.5	71.5	177	-	70	
		37.5	120	120	310	900	64	
		37.5	120	120	310	900	80	
		37.5	120	120	310	900	100	
		41.0	132.5	132.5	329	580	125	
		37.5	120	120	310	(580)	140(160)	
41.0	132.5	132.5	329	-	175			
37.5	120	120	310	580	200			
41.0	132.5	132.5	329	(900)	250(256)			
37.5	120	120	310	(580)	280(320)			
41.0	132.5	132.5	329	(400)	350(512)			
故障停滞扭矩 Emergency stop torque	N·m	2倍额定输出扭矩 2 times Rated output torque						
额定输入转速 Norminal input speed	rmp	3000	3000	3000	2000	2000		
最大输入转速 Maximum input speed	rmp	6000	6000	6000	3500	3500		
最大径向力 Maximum radial force	N	170	1020	1020	2230	3200		
最大轴向力 Maximum axial force	N	120	850	850	1550	3000		
效率 Efficiency	%	Single [97%]			Double [95%]			
平均寿命 Average lifetime	h	20000						
重量 Weight	kg	1.4	3.7	4.7	6.9	19	1	
		1.6	4.2	5.3	8.9	25	2	
		1.8	4.7	5.9	11.2	31	3	

减速机性能资料 Gear box performance information

型号 Model	单位 Unit	PLF060	PLF080	PLF090	PLF120	PLF160	减速比 Ratio	Stage	
转动惯量 Moment of inertia	kgcm ²	0.107	0.4	0.4	1.65	4.31	3	1	
		0.094	0.309	0.309	1.22	5.15	4		
		0.092	0.291	0.291	1.15	4.93	5		
		0.091	0.285	0.285	1.13	(4.84)	7(8)		
		0.091	0.283	0.283	1.11	-	10		
		0.4	0.4	1.65	6.31	12	2		
		0.309	0.309	1.65	-	15			
		0.094	0.291	0.291	1.22	5.15		16	
		0.092	0.291	0.291	1.15	4.93		20	
		0.092	0.291	0.291	1.15	4.93		25	
		0.091	0.285	0.285	1.13	(4.84)		28(32)	
		0.091	0.285	0.285	1.13	-		35	
		0.091	0.2835	0.2835	1.11	4.84		40	
		0.091	0.283	0.283	1.11	(4.84)		50(64)	
		0.091	0.283	0.283	1.11	-		70	
		0.092	0.291	0.291	1.15	4.93	64	3	
		0.092	0.291	0.291	1.15	4.93	80		
		0.092	0.291	0.291	1.15	4.93	100		
		0.092	0.291	0.291	1.15	4.84	125		
		0.091	0.291	0.291	1.13	(4.84)	140(160)		
0.091	0.291	0.291	1.13	-	175				
0.091	0.283	0.283	1.11	4.84	200				
0.091	0.283	0.283	1.11	(4.84)	250(256)				
0.091	0.283	0.283	1.11	(4.84)	280(320)				
0.091	0.283	0.283	1.11	(4.84)	350(512)				
噪音 Noise	dB	60	65	65	68	70			
润滑 Lubricating		合成油脂润滑 Synthetic grease lubrication							
防护等级 levels of protection		IP65							

外形尺寸图表 Outline dimensional

PLF-060-L1

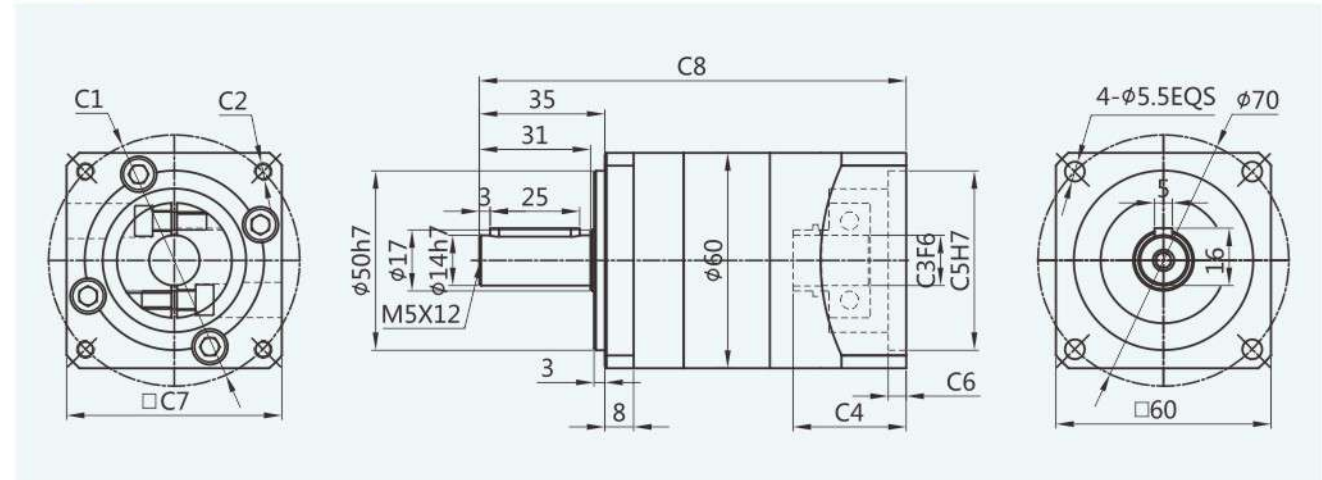

适配电机输入接口尺寸(左端为输入尺寸)
Adapter motor input interface size (The left end is the input size)

尺寸 Size	C1	C2	C3	C4	C5	C6	C7	C8
PLF-060-L1	□47.14	4-M4	Φ8	31.5	Φ38.1	5.0	60	119
	Φ46	4-M4	Φ8	31.5	Φ30	5.0	60	119
	Φ45	4-M3	Φ8	31.5	Φ30	5.0	60	119
	Φ70	4-M4/4-M5	Φ14	31.5	Φ50	5.0	60	119

PLF-060-L2

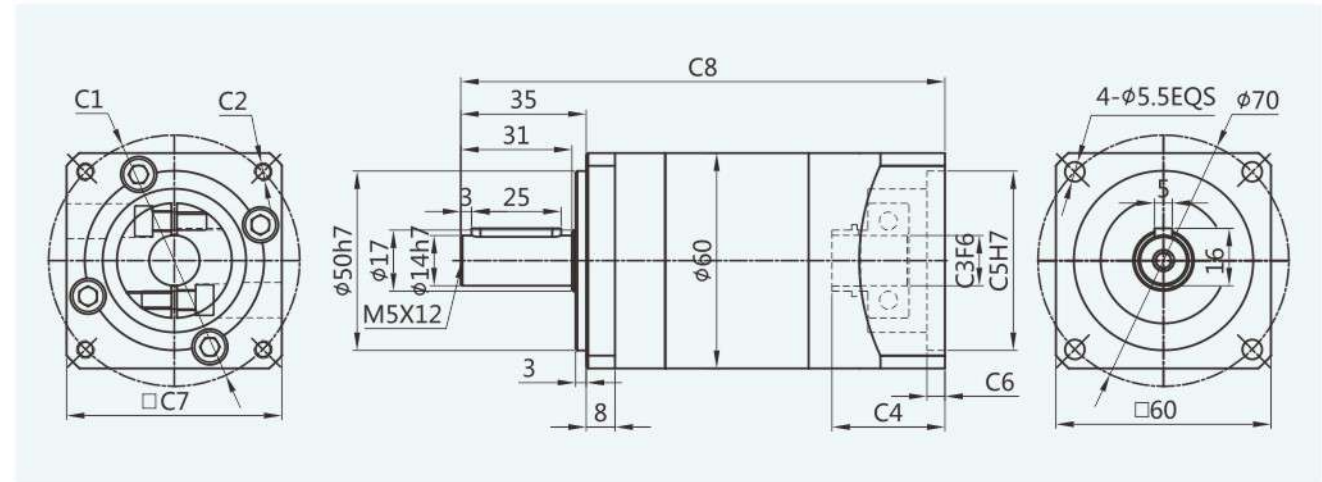

适配电机输入接口尺寸(左端为输入尺寸)
Adapter motor input interface size (The left end is the input size)

尺寸 Size	C1	C2	C3	C4	C5	C6	C7	C8
PLF-060-L2	□47.14	4-M4	Φ8	31.5	Φ38.1	5.0	60	135
	Φ46	4-M4	Φ8	31.5	Φ30	5.0	60	135
	Φ45	4-M3	Φ8	31.5	Φ30	5.0	60	135
	Φ70	4-M4/4-M5	Φ14	31.5	Φ50	5.0	60	135

外形尺寸图表
Outline dimensional

PLF-060-L3

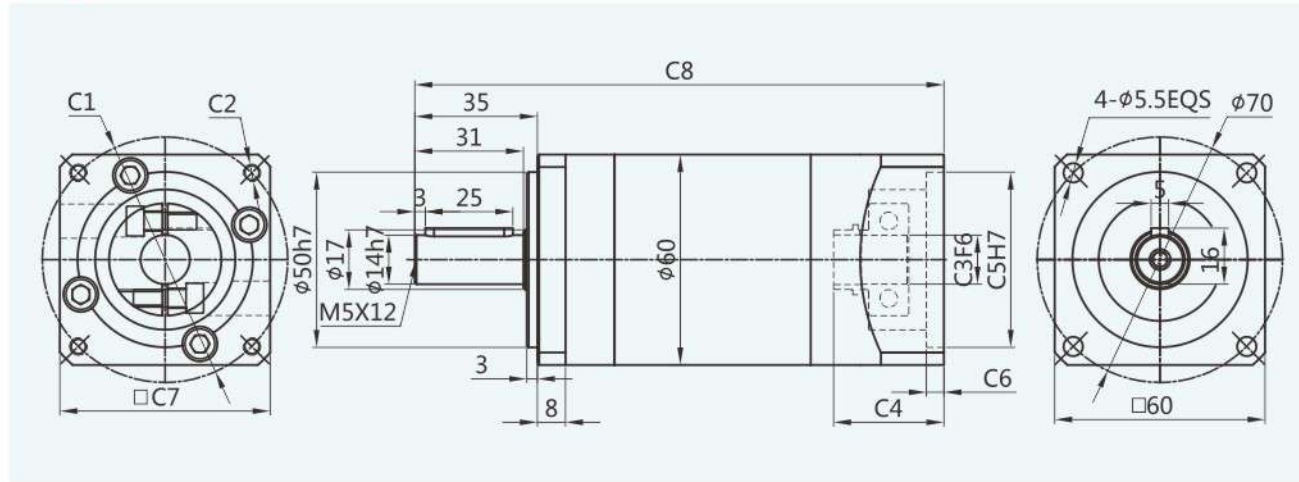

适配电机输入接口尺寸(左端为输入尺寸)
Adapter motor input interface size (The left end is the input size)

尺寸 Size	C1	C2	C3	C4	C5	C6	C7	C8
PLF-060-L3	□47.14	4-M4	Φ8	31.5	Φ38.1	5.0	60	151
	Φ46	4-M4	Φ8	31.5	Φ30	5.0	60	151
	Φ45	4-M3	Φ8	31.5	Φ30	5.0	60	151
	Φ70	4-M4/4-M5	Φ14	31.5	Φ50	5.0	60	151

PLF-080-L1

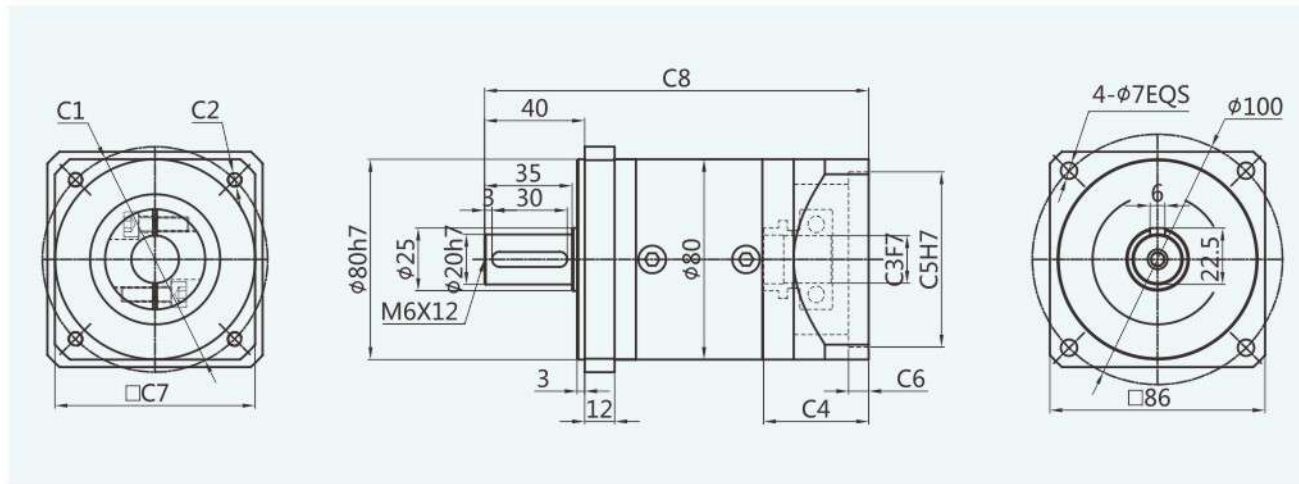

适配电机输入接口尺寸(左端为输入尺寸)
Adapter motor input interface size (The left end is the input size)

尺寸 Size	C1	C2	C3	C4	C5	C6	C7	C8
PLF-080-L1	Φ70	4-M4/4-M5	Φ14	42	Φ50	8.0	80	153
	□69.6	4-M6	Φ14	42	Φ73	8.0	80	153
	Φ90	4-M5/4-M6	Φ19	42	Φ70	8.0	80	153

外形尺寸图表
Outline dimensional

PLF-080-L2

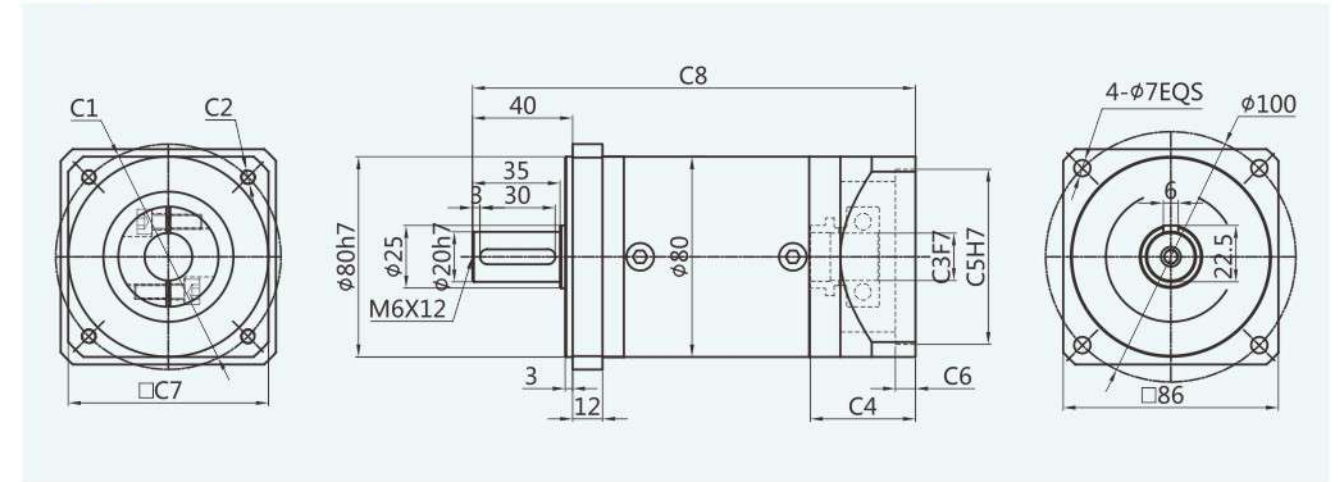

适配电机输入接口尺寸(左端为输入尺寸)
Adapter motor input interface size (The left end is the input size)

尺寸 Size	C1	C2	C3	C4	C5	C6	C7	C8
PLF-080-L2	Φ70	4-M4/4-M5	Φ14	42	Φ50	8.0	80	176.5
	□69.6	4-M6	Φ14	42	Φ73	8.0	80	176.5
	Φ90	4-M5/4-M6	Φ19	42	Φ70	8.0	80	176.5

PLF-090-L1

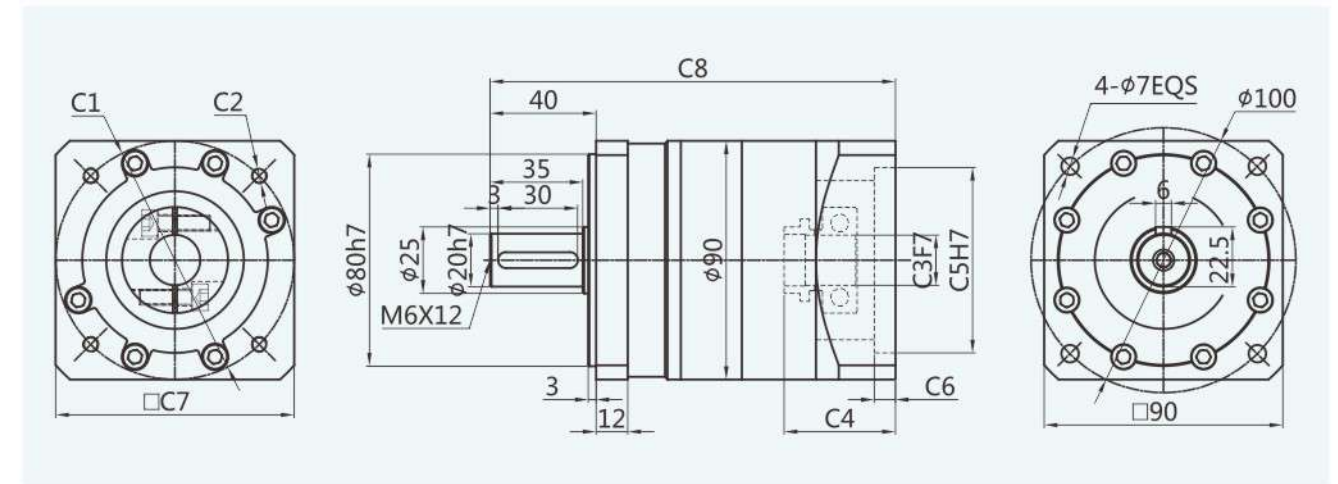

适配电机输入接口尺寸(左端为输入尺寸)
Adapter motor input interface size (The left end is the input size)

尺寸 Size	C1	C2	C3	C4	C5	C6	C7	C8
PLF-090-L1	Φ70	4-M4/4-M5	Φ14	42	Φ50	8.0	90	153
	□69.6	4-M6	Φ14	42	Φ73	8.0	90	153
	Φ90	4-M5/4-M6	Φ19	42	Φ70	8.0	90	153

外形尺寸图表
Outline dimensional

PLF-090-L2

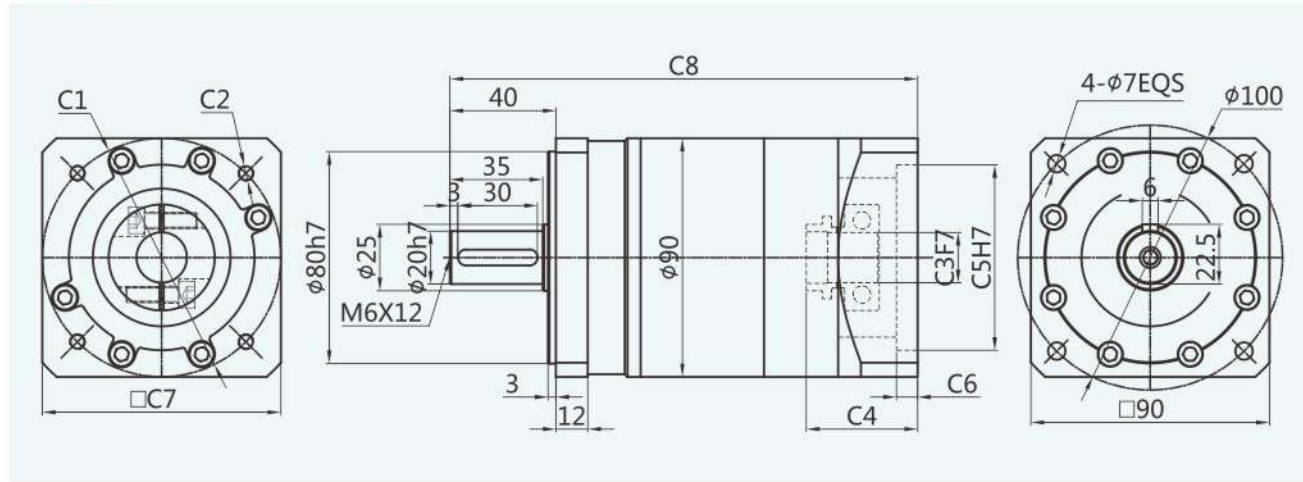

适配电机输入接口尺寸(左端为输入尺寸)
Adapter motor input interface size (The left end is the input size)

尺寸 Size	C1	C2	C3	C4	C5	C6	C7	C8
PLF-090-L2	φ70	4-M4/4-M5	φ14	42	φ50	8.0	90	176.5
	□69.6	4-M6	φ14	42	φ73	8.0	90	176.5
	φ90	4-M5/4-M6	φ19	42	φ70	8.0	90	176.5

PLF-090-L3

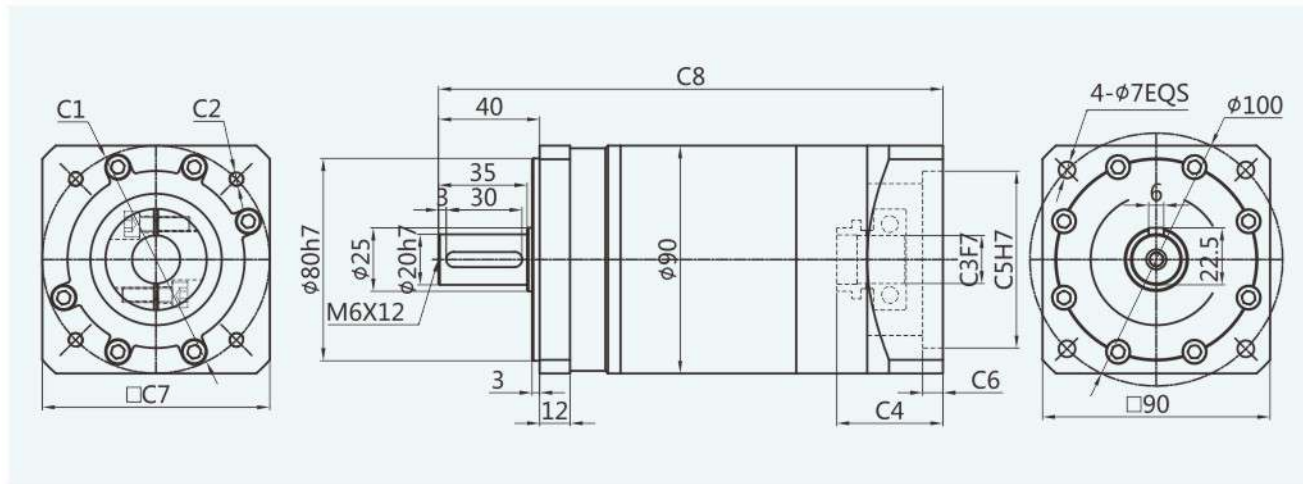

适配电机输入接口尺寸(左端为输入尺寸)
Adapter motor input interface size (The left end is the input size)

尺寸 Size	C1	C2	C3	C4	C5	C6	C7	C8
PLF-090-L3	φ70	4-M4/4-M5	φ14	42	φ50	8.0	90	199.5
	69.6	4-M6	φ14	42	φ73	8.0	90	199.5
	φ90	4-M5/4-M6	φ19	42	φ70	8.0	90	199.5

外形尺寸图表
Outline dimensional

PLF-120-L1

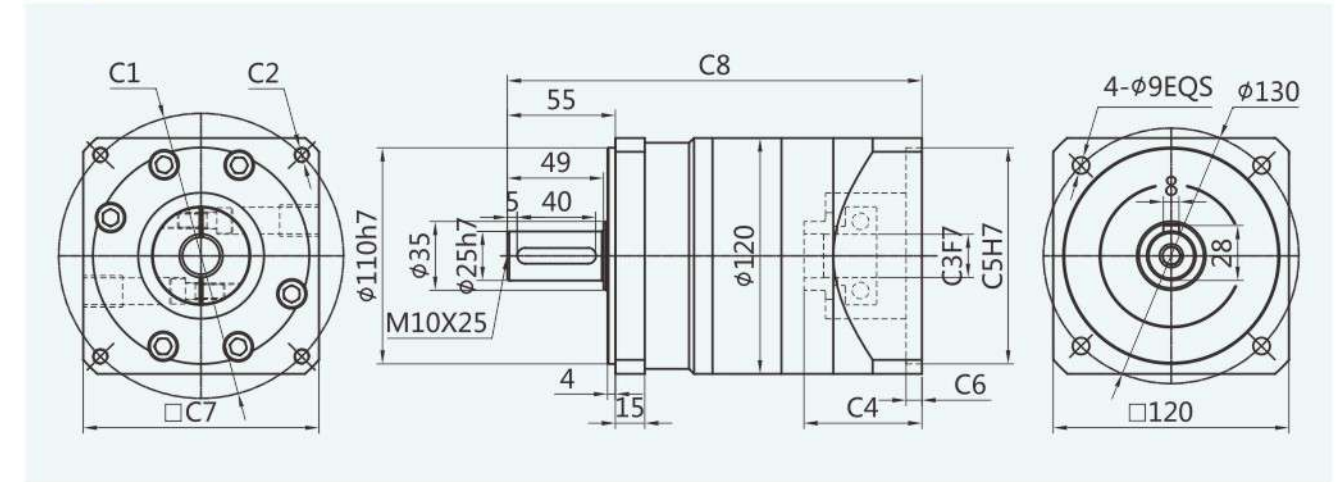

适配电机输入接口尺寸(左端为输入尺寸)
Adapter motor input interface size (The left end is the input size)

尺寸 Size	C1	C2	C3	C4	C5	C6	C7	C8
PLF-120-L1	φ90	4-M5/4-M6	φ19	47	φ70	8	90	200
	φ115	4-M8	φ19/φ22	60	φ95	8	130	211
	φ130	4-M8	φ19/φ22	60	φ95	8	130	211
	φ145	4-M8	φ19/φ22/φ24	60	φ110	8	180	211

PLF-120-L2

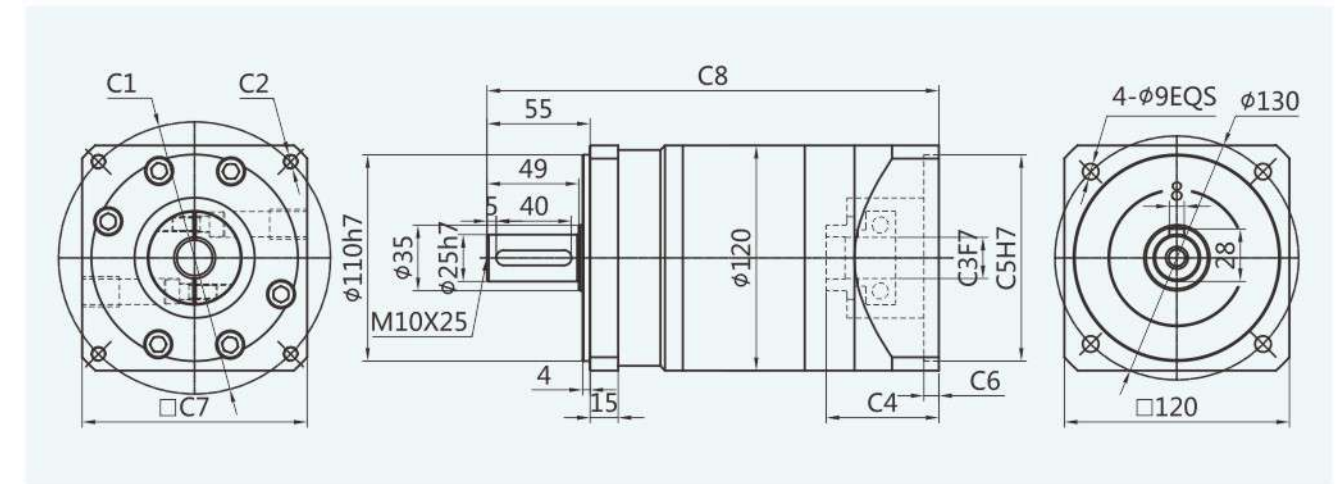

适配电机输入接口尺寸(左端为输入尺寸)
Adapter motor input interface size (The left end is the input size)

尺寸 Size	C1	C2	C3	C4	C5	C6	C7	C8
PLF-120-L2	φ90	4-M5/4-M6	φ19	47	φ70	8	90	230
	φ115	4-M8	φ19/φ22	60	φ95	8	130	241
	φ130	4-M8	φ19/φ22	60	φ95	8	130	241
	φ145	4-M8	φ19/φ22/φ24	60	φ110	8	180	241

外形尺寸图表
Outline dimensional

PLF-120-L3

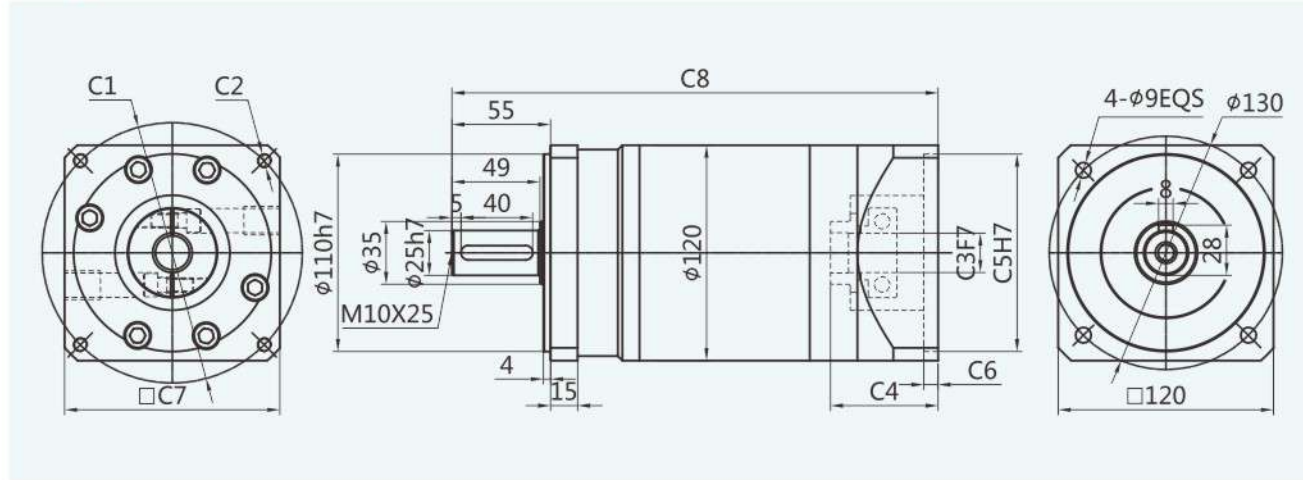

适配电机输入接口尺寸(左端为输入尺寸)
Adapter motor input interface size (The left end is the input size)

尺寸 Size	C1	C2	C3	C4	C5	C6	C7	C8
PLF-120-L3	Φ90	4-M5/4-M6	Φ19	47	Φ70	8	90	260
	Φ115	4-M8	Φ19/Φ22	60	Φ95	8	130	271
	Φ130	4-M8	Φ19/Φ22	60	Φ95	8	130	271
	Φ145	4-M8	Φ19/Φ22/Φ24	60	Φ110	8	180	271

PLF-160-L1

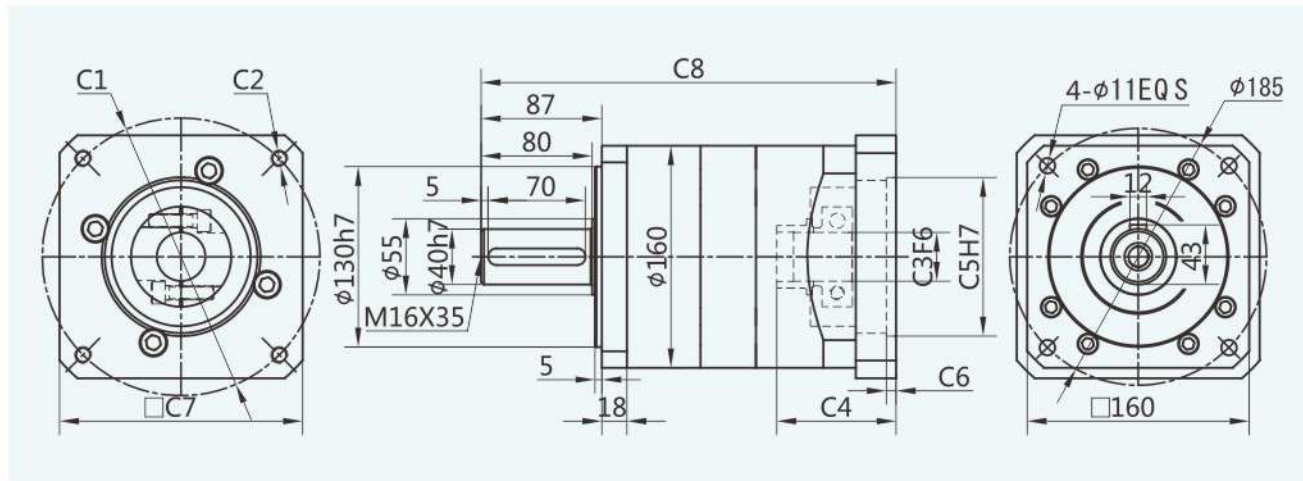

适配电机输入接口尺寸(左端为输入尺寸)
Adapter motor input interface size (The left end is the input size)

尺寸 Size	C1	C2	C3	C4	C5	C6	C7	C8
PLF-160-L1	Φ130	4-M8	Φ22	62	Φ95	7	142	275
	Φ145	4-M8	Φ22/Φ24	62	Φ110	7	142	275
	Φ165	4-M10	Φ32	62	Φ130	7	142	275
	Φ200	4-M12	Φ35	86	Φ114.3	7	175	299
	Φ200	4-M12	Φ35	117	Φ114.3	7	175	330
	Φ215	4-M12	Φ38/Φ42	86	Φ180	7	190	299

外形尺寸图表
Outline dimensional

PLF-160-L2

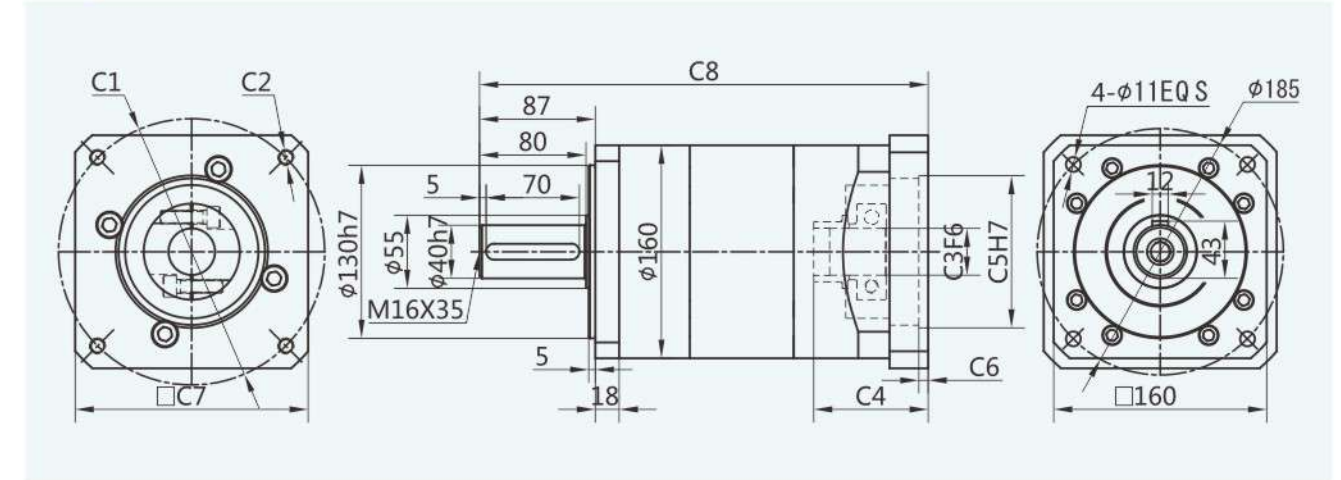

适配电机输入接口尺寸(左端为输入尺寸)
Adapter motor input interface size (The left end is the input size)

尺寸 Size	C1	C2	C3	C4	C5	C6	C7	C8
PLF-160-L2	Φ130	4-M8	Φ22	62	Φ95	7	142	313
	Φ145	4-M8	Φ22/Φ24	62	Φ110	7	142	313
	Φ165	4-M10	Φ32	62	Φ130	7	142	313
	Φ200	4-M12	Φ35	86	Φ114.3	7	175	337
	Φ200	4-M12	Φ35	117	Φ114.3	7	175	368
	Φ215	4-M12	Φ38/Φ42	86	Φ180	7	190	337

PLF-160-L3

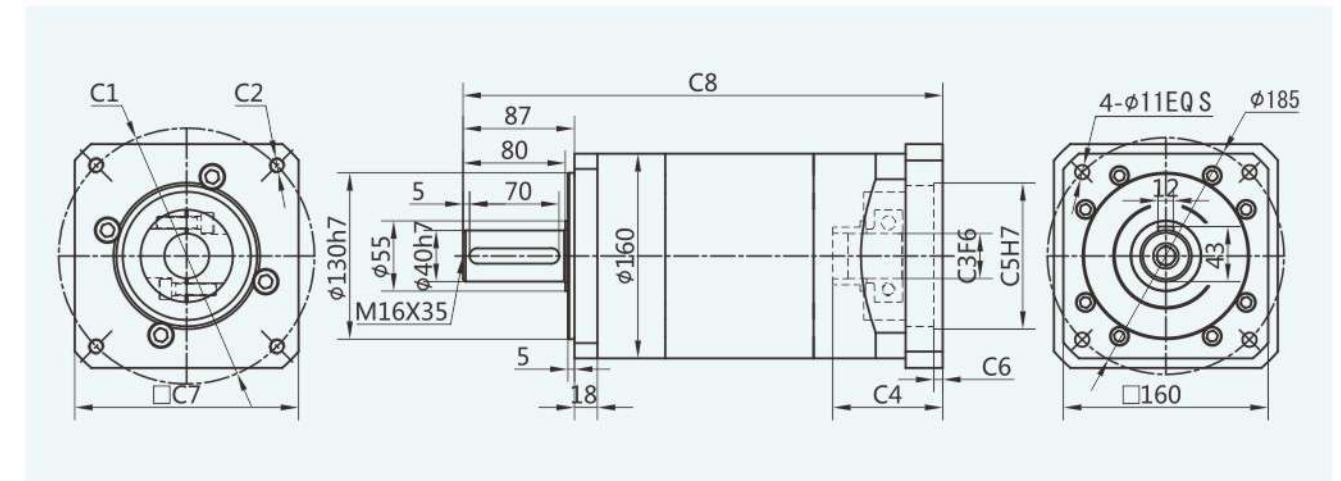

适配电机输入接口尺寸(左端为输入尺寸)
Adapter motor input interface size (The left end is the input size)

尺寸 Size	C1	C2	C3	C4	C5	C6	C7	C8
PLF-160-L3	Φ130	4-M8	Φ22	62	Φ95	7	142	351
	Φ145	4-M8	Φ22/Φ24	62	Φ110	7	142	351
	Φ165	4-M10	Φ32	62	Φ130	7	142	351
	Φ200	4-M12	Φ35	86	Φ114.3	7	175	375
	Φ200	4-M12	Φ35	117	Φ114.3	7	175	406
	Φ215	4-M12	Φ38/Φ42	86	Φ180	7	190	375

- ✓ PLE060
- ✓ PLE080
- ✓ PLE090
- ✓ PLE120
- ✓ PLE160



PLE Series

PLE系列减速机核心特性

The Core Characteristics of PLE Series Reducer

- 1 采用直齿齿轮传动，经渗碳淬火处理，齿向齿廓修形处理，确保运行平稳，噪音小；
- 2 结构简单，可大批量生产，且交货期快性价比高；
- 3 减速机种类齐全，可以满足市场上绝大多数减速机的配合。

- 1 Adopt straight tooth gear transmission, through carburizing and quenching treatment, tooth profile modification treatment, ensure smooth operation, low noise.
- 2 Simple structure, mass production, and fast delivery time and high cost performance.
- 3 Reducer has a complete range, which can meet the needs of most reducer in the market.

减速机性能资料

Gear box performance information

型号 Model	单位 Unit	PLE060	PLE080	PLE090	PLE120	PLE160	减速比 Ratio	Stage	
额定输出扭矩 Rated output torque	N·m	16.5	60	60	148	310	3	1	
		27	86	86	222	605	4		
		27	94.5	94.5	235	420	5		
		19.5	64	64	158	(270)	7(8)		
		8.5	39.5	39.5	93	-	10		
			96	96	250	680	12		
			96	96	250	-	15	2	
		30	96	96	250	680	16		
		30	96	96	250	680	20		
		33	105.5	105.5	264	460	25		
		30	96	96	250	(680)	28(32)		
		33	105.5	105.5	264	-	35		
			30	96	96	250	460	40	3
			33	105.5	105.5	264	(310)	50(64)	
			21.5	71.5	71.5	177	-	70	
			37.5	120	120	310	900	64	
			37.5	120	120	310	900	80	
			37.5	120	120	310	900	100	
			41.0	132.5	132.5	329	580	125	
			37.5	120	120	310	(580)	140(160)	
	41.0	132.5	132.5	329	-	175			
	37.5	120	120	310	580	200			
	41.0	132.5	132.5	329	(900)	250(256)			
	37.5	120	120	310	(580)	280(320)			
	41.0	132.5	132.5	329	(400)	350(512)			
故障停滞扭矩 Emergency stop torque	N·m	2倍额定输出扭矩 2 times Rated output torque							
额定输入转速 Nominal input speed	rmp	3000	3000	3000	2000	2000			
最大输入转速 Maximum input speed	rmp	6000	6000	6000	3500	3500			
最大径向力 Maximum radial force	N	170	1020	1020	2230	3200			
最大轴向力 Maximum axial force	N	120	850	850	1550	3000			
效率 Efficiency	%	Single [97%]			Double [95%]				
平均寿命 Average lifetime	h	20000							
重量 Weight	kg	1.4	3.7	4.7	6.9	19	1		
		1.6	4.2	5.3	8.9	25	2		
		1.8	4.7	5.9	11.2	31	3		

减速机性能资料 Gear box performance information

型号 Model	单位 Unit	PLE060	PLE080	PLE090	PLE120	PLE160	减速比 Ratio	Stage
转动惯量 Moment of inertia	kgcm ²	0.107	0.4	0.4	1.65	4.13	3	1
		0.094	0.309	0.309	1.22	5.15	4	
		0.092	0.291	0.291	1.15	4.93	5	
		0.091	0.285	0.285	1.13	(4.84)	7(8)	
		0.091	0.283	0.283	1.11	-	10	
		0.4	0.4	1.65	6.13	12	2	
		0.309	0.309	1.65	-	15		
		0.094	0.291	0.291	1.22	5.15		16
		0.092	0.291	0.291	1.15	4.93		20
		0.092	0.291	0.291	1.15	4.93		25
		0.091	0.285	0.285	1.13	(4.84)		28(32)
		0.091	0.285	0.285	1.13	-		35
		0.091	0.2835	0.2835	1.11	4.84		40
		0.091	0.283	0.283	1.11	-		50
		0.091	0.283	0.283	1.11	(4.84)		70(64)
		0.092	0.291	0.291	1.15	4.93	64	3
		0.092	0.291	0.291	1.15	4.93	80	
		0.092	0.291	0.291	1.15	4.93	100	
		0.092	0.291	0.291	1.15	4.84	125	
		0.091	0.291	0.291	1.13	(4.84)	140(160)	
		0.091	0.291	0.291	1.13	-	175	
		0.091	0.283	0.283	1.11	4.84	200	
		0.091	0.283	0.283	1.11	(4.84)	250(256)	
		0.091	0.283	0.283	1.11	(4.84)	280(320)	
0.091	0.283	0.283	1.11	(4.84)	350(512)			
噪音 Noise	dB	60	65	65	68	70		
润滑 Lubricating		合成油脂润滑 Synthetic grease lubrication						
防护等级 levels of protection		IP65						

外形尺寸图表 Outline dimensional

PLE-060-L1

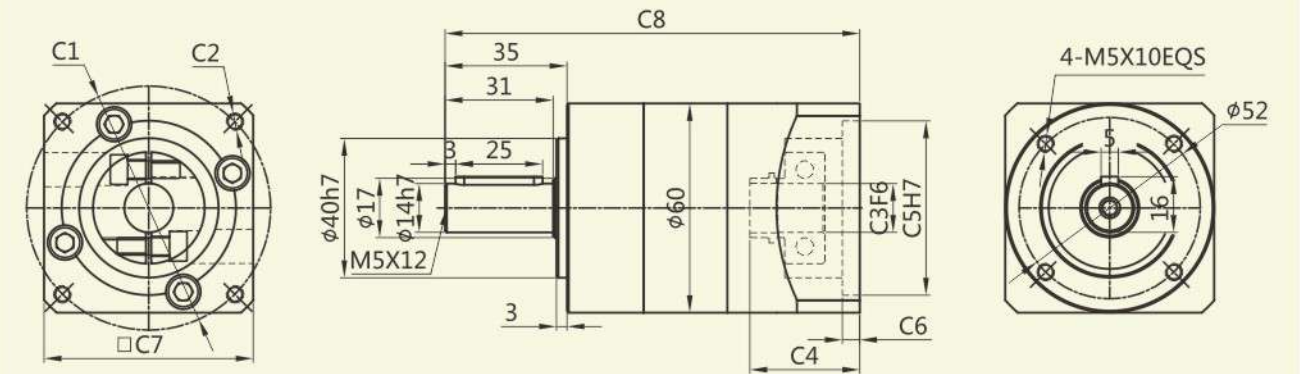

适配电机输入接口尺寸(左端为输入尺寸)
Adapter motor input interface size (The left end is the input size)

尺寸 Size	C1	C2	C3	C4	C5	C6	C7	C8
PLE-060-L1	$\square 47.14$	4-M4	$\phi 8$	31.5	$\phi 38.1$	5.0	60	119
	$\phi 46$	4-M4	$\phi 8$	31.5	$\phi 30$	5.0	60	119
	$\phi 45$	4-M3	$\phi 8$	31.5	$\phi 30$	5.0	60	119
	$\phi 70$	4-M4/4-M5	$\phi 14$	31.5	$\phi 50$	5.0	60	119

PLE-060-L2

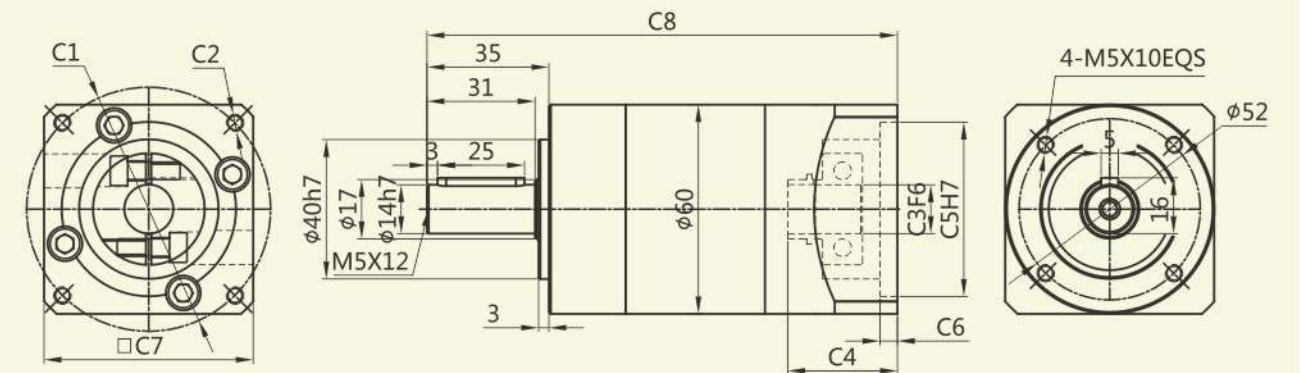

适配电机输入接口尺寸(左端为输入尺寸)
Adapter motor input interface size (The left end is the input size)

尺寸 Size	C1	C2	C3	C4	C5	C6	C7	C8
PLE-060-L2	$\square 47.14$	4-M4	$\phi 8$	31.5	$\phi 38.1$	5.0	60	135
	$\phi 46$	4-M4	$\phi 8$	31.5	$\phi 30$	5.0	60	135
	$\phi 45$	4-M3	$\phi 8$	31.5	$\phi 30$	5.0	60	135
	$\phi 70$	4-M4/4-M5	$\phi 14$	31.5	$\phi 50$	5.0	60	135

外形尺寸图表
Outline dimensional

PLE-060-L3

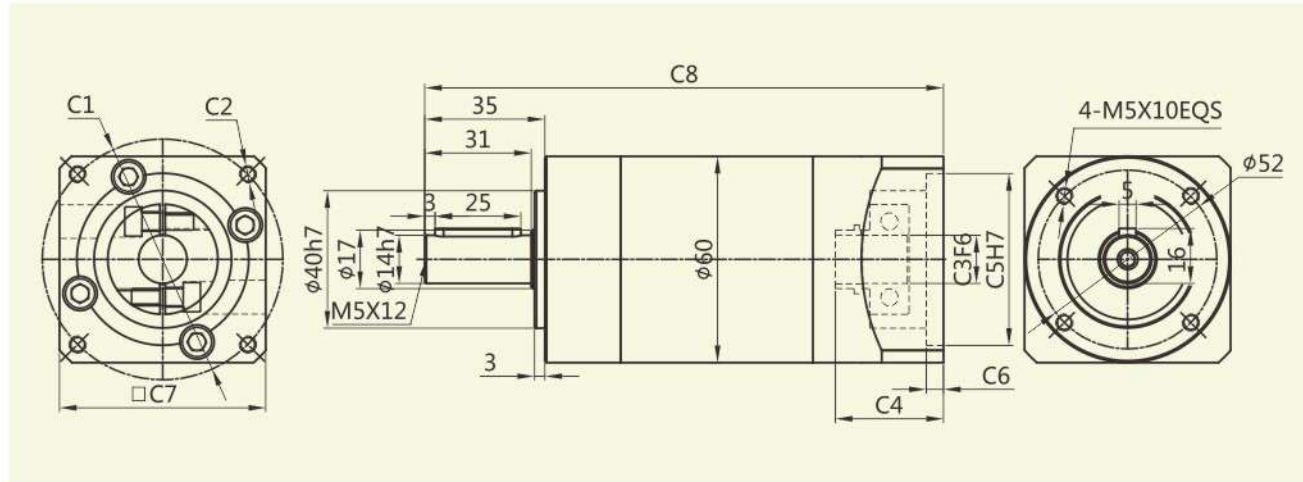

适配电机输入接口尺寸(左端为输入尺寸)
Adapter motor input interface size (The left end is the input size)

尺寸 Size	C1	C2	C3	C4	C5	C6	C7	C8
PLE-060-L3	□47.14	4-M4	Φ8	31.5	Φ38.1	5.0	60	151
	Φ46	4-M4	Φ8	31.5	Φ30	5.0	60	151
	Φ45	4-M3	Φ8	31.5	Φ30	5.0	60	151
	Φ70	4-M4/4-M5	Φ14	31.5	Φ50	5.0	60	151

PLE-080-L1

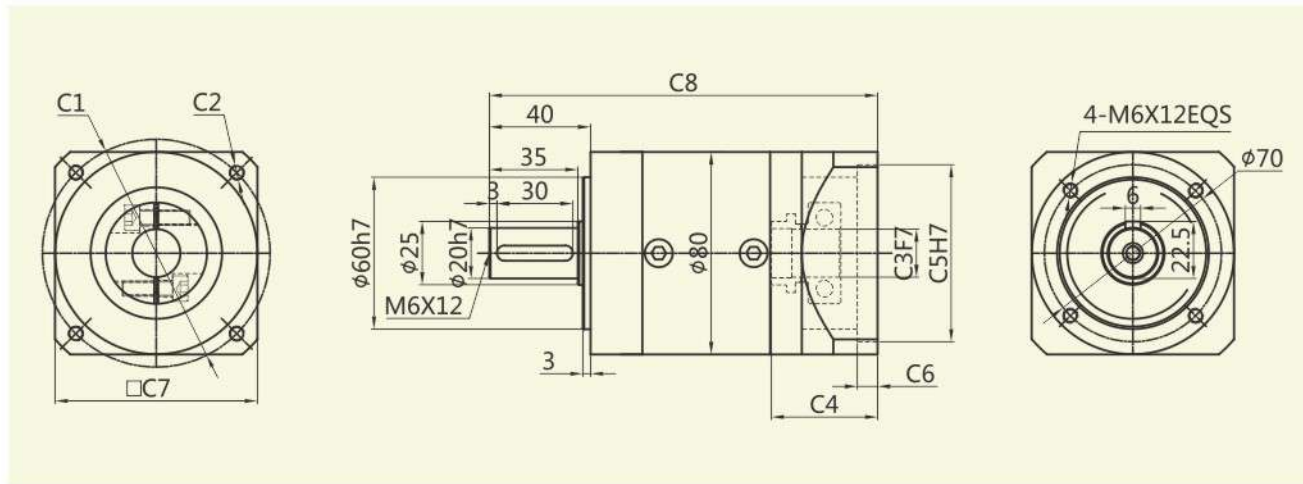

适配电机输入接口尺寸(左端为输入尺寸)
Adapter motor input interface size (The left end is the input size)

尺寸 Size	C1	C2	C3	C4	C5	C6	C7	C8
PLE-080-L1	Φ70	4-M4/4-M5	Φ14	42	Φ50	8.0	80	153
	69.6	4-M6	Φ14	42	Φ73	8.0	80	153
	Φ90	4-M5/4-M6	Φ19	42	Φ70	8.0	80	153

外形尺寸图表
Outline dimensional

PLE-080-L2

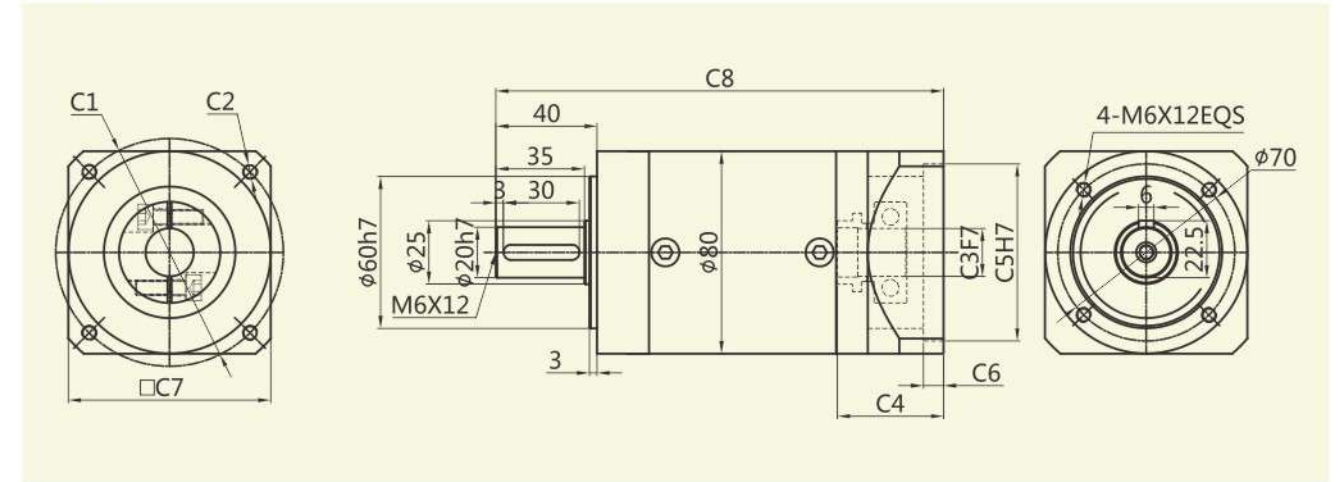

适配电机输入接口尺寸(左端为输入尺寸)
Adapter motor input interface size (The left end is the input size)

尺寸 Size	C1	C2	C3	C4	C5	C6	C7	C8
PLE-080-L2	Φ70	4-M4/4-M5	Φ14	42	Φ50	8.0	80	176.5
	69.6	4-M6	Φ14	42	Φ73	8.0	80	176.5
	Φ90	4-M5/4-M6	Φ19	42	Φ70	8.0	80	176.5

PLE-090-L1

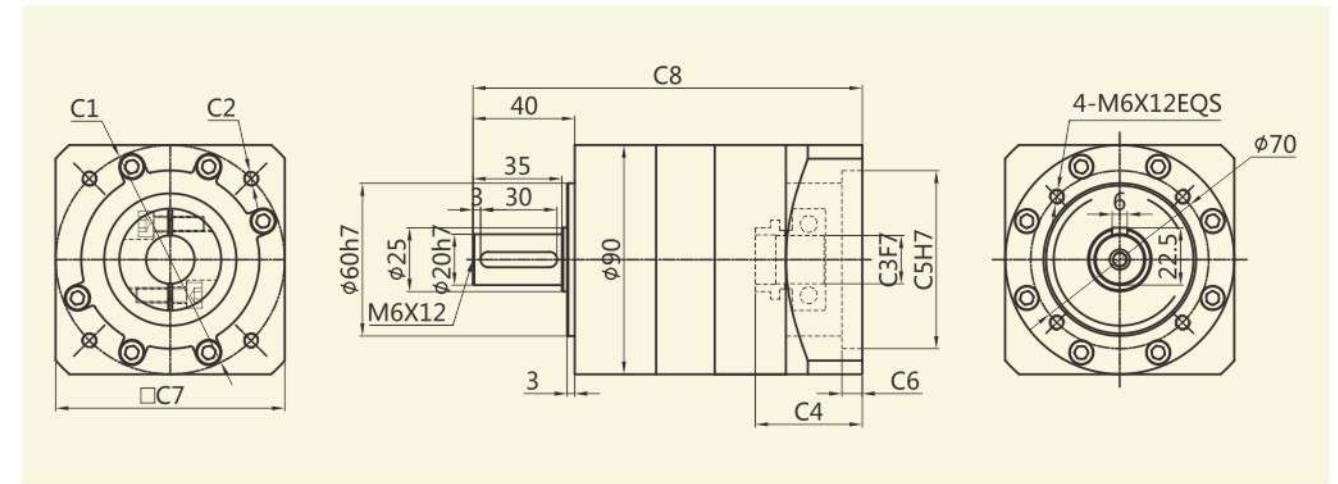

适配电机输入接口尺寸(左端为输入尺寸)
Adapter motor input interface size (The left end is the input size)

尺寸 Size	C1	C2	C3	C4	C5	C6	C7	C8
PLE-090-L1	Φ70	4-M4/4-M5	Φ14	42	Φ50	8.0	90	153
	69.6	4-M6	Φ14	42	Φ73	8.0	90	153
	Φ90	4-M5/4-M6	Φ19	42	Φ70	8.0	90	153

外形尺寸图表

Outline dimensional

PLE-090-L2

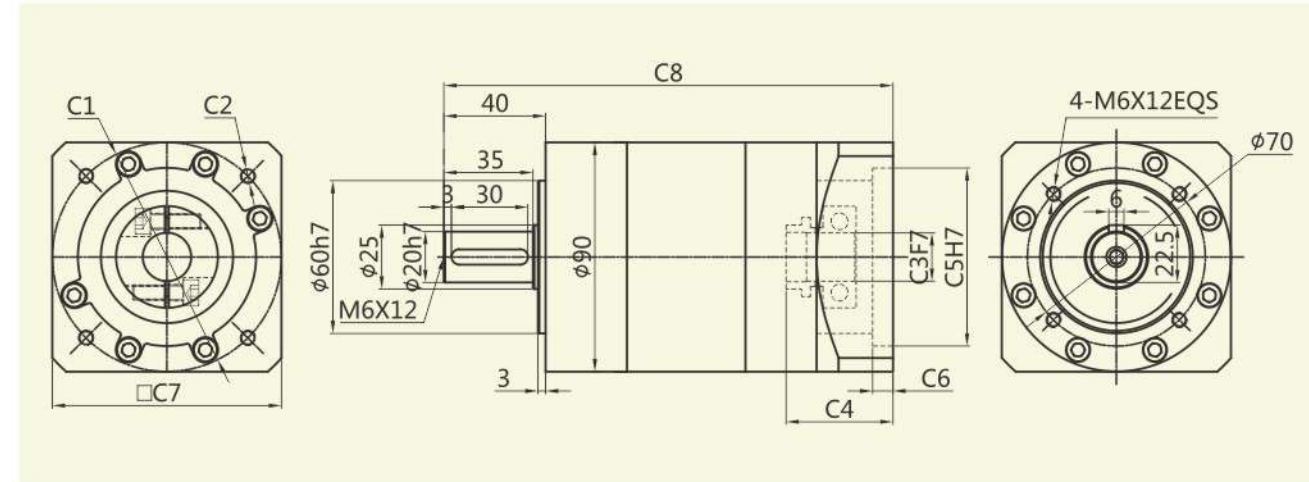

适配电机输入接口尺寸(左端为输入尺寸)
Adapter motor input interface size (The left end is the input size)

尺寸 Size	C1	C2	C3	C4	C5	C6	C7	C8
PLE-090-L2	$\phi 70$	4-M4/4-M5	$\phi 14$	42	$\phi 50$	8.0	90	176.5
	69.6	4-M6	$\phi 14$	42	$\phi 73$	8.0	90	176.5
	$\phi 90$	4-M5/4-M6	$\phi 19$	42	$\phi 70$	8.0	90	176.5

PLE-090-L3

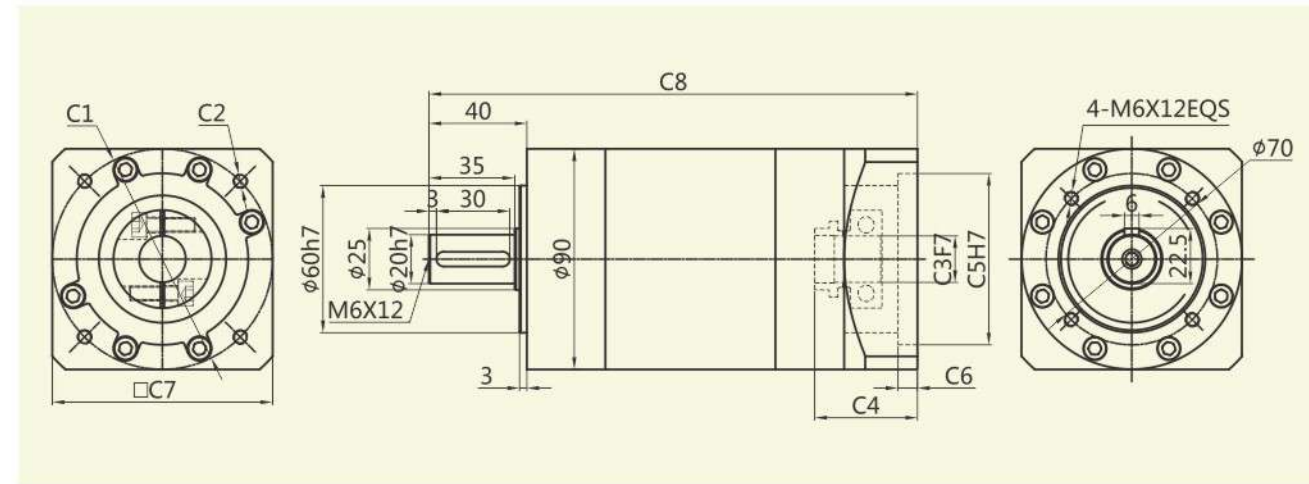

适配电机输入接口尺寸(左端为输入尺寸)
Adapter motor input interface size (The left end is the input size)

尺寸 Size	C1	C2	C3	C4	C5	C6	C7	C8
PLE-090-L3	$\phi 70$	4-M4/4-M5	$\phi 14$	42	$\phi 50$	8.0	90	199.5
	69.6	4-M6	$\phi 14$	42	$\phi 73$	8.0	90	199.5
	$\phi 90$	4-M5/4-M6	$\phi 19$	42	$\phi 70$	8.0	90	199.5

外形尺寸图表

Outline dimensional

PLE-120-L1

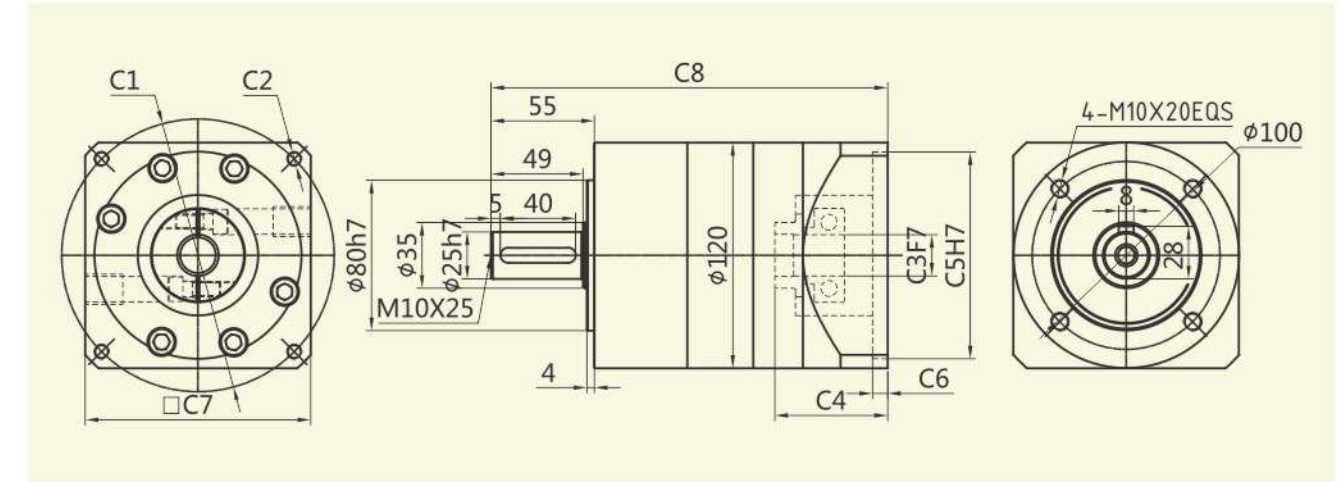

适配电机输入接口尺寸(左端为输入尺寸)
Adapter motor input interface size (The left end is the input size)

尺寸 Size	C1	C2	C3	C4	C5	C6	C7	C8
PLE-120-L1	$\phi 90$	4-M5/4-M6	$\phi 19$	47	$\phi 70$	8	90	200
	$\phi 115$	4-M8	$\phi 19/\phi 22$	60	$\phi 95$	8	130	211
	$\phi 130$	4-M8	$\phi 19/\phi 22$	60	$\phi 95$	8	130	211
	$\phi 145$	4-M8	$\phi 19/\phi 22/\phi 24$	60	$\phi 110$	8	180	211

PLE-120-L2

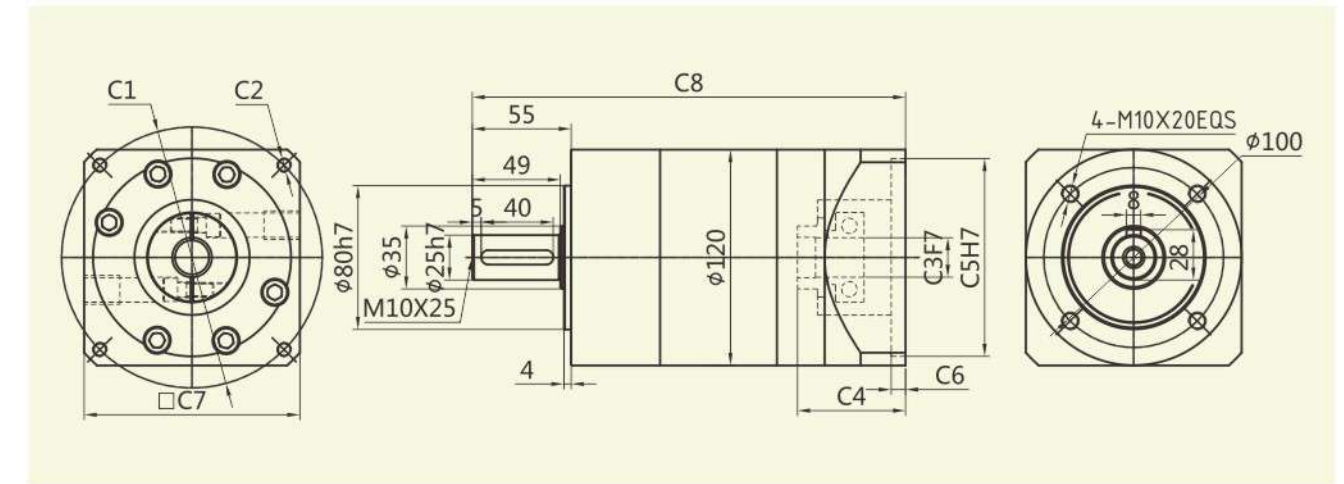

适配电机输入接口尺寸(左端为输入尺寸)
Adapter motor input interface size (The left end is the input size)

尺寸 Size	C1	C2	C3	C4	C5	C6	C7	C8
PLE-120-L2	$\phi 90$	4-M5/4-M6	$\phi 19$	47	$\phi 70$	8	90	230
	$\phi 115$	4-M8	$\phi 19/\phi 22$	60	$\phi 95$	8	130	241
	$\phi 130$	4-M8	$\phi 19/\phi 22$	60	$\phi 95$	8	130	241
	$\phi 145$	4-M8	$\phi 19/\phi 22/\phi 24$	60	$\phi 110$	8	180	241

外形尺寸图表
Outline dimensional

PLE-120-L3

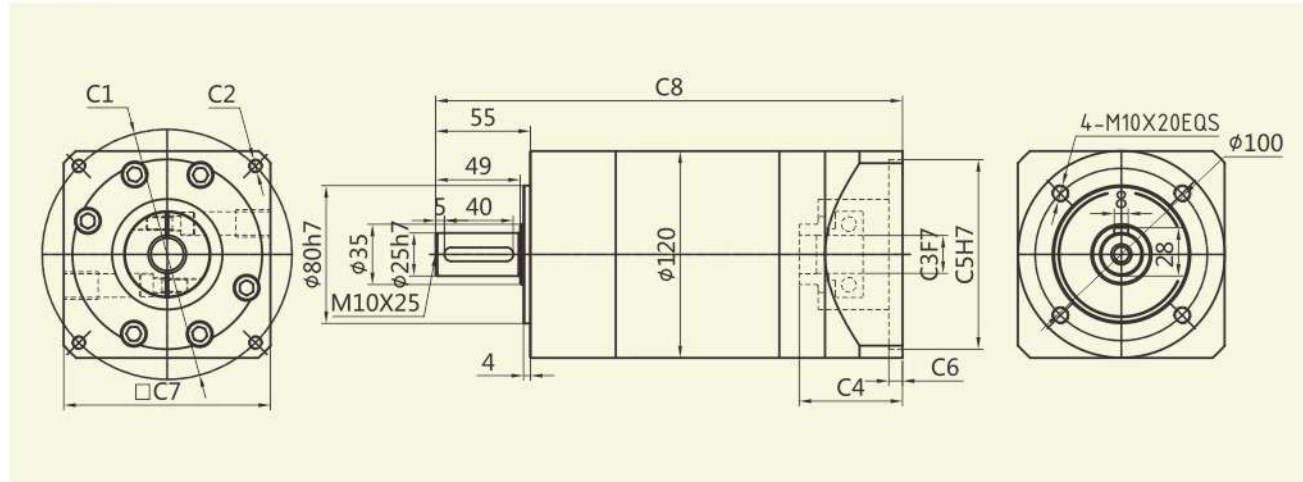

适配电机输入接口尺寸(左端为输入尺寸)
Adapter motor input interface size (The left end is the input size)

尺寸 Size	C1	C2	C3	C4	C5	C6	C7	C8
PLE-120-L3	$\phi 90$	4-M5/4-M6	$\phi 19$	47	$\phi 70$	8	90	260
	$\phi 115$	4-M8	$\phi 19/\phi 22$	60	$\phi 95$	8	130	271
	$\phi 130$	4-M8	$\phi 19/\phi 22$	60	$\phi 95$	8	130	271
	$\phi 145$	4-M8	$\phi 19/\phi 22/\phi 24$	60	$\phi 110$	8	180	271

PLE-160-L1

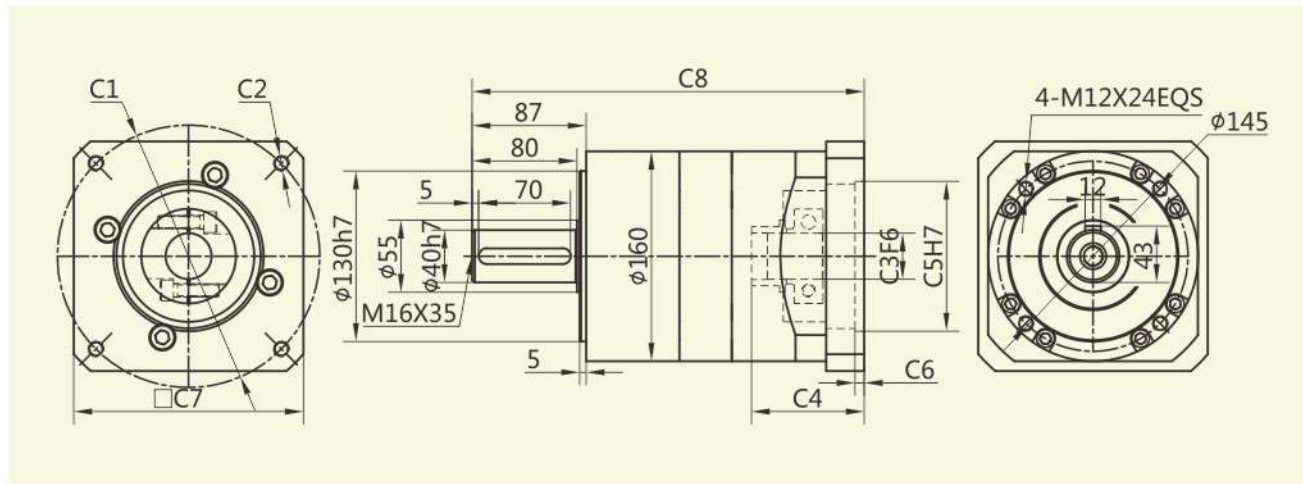

适配电机输入接口尺寸(左端为输入尺寸)
Adapter motor input interface size (The left end is the input size)

尺寸 Size	C1	C2	C3	C4	C5	C6	C7	C8
PLE-160-L1	$\phi 130$	4-M8	$\phi 22$	62	$\phi 95$	7	142	275
	$\phi 145$	4-M8	$\phi 22/\phi 24$	62	$\phi 110$	7	142	275
	$\phi 165$	4-M10	$\phi 32$	62	$\phi 130$	7	142	275
	$\phi 200$	4-M12	$\phi 35$	86	$\phi 114.3$	7	175	299
	$\phi 200$	4-M12	$\phi 35$	117	$\phi 114.3$	7	175	330
	$\phi 215$	4-M12	$\phi 38/\phi 42$	86	$\phi 180$	7	190	299

外形尺寸图表
Outline dimensional

PLE-160-L2

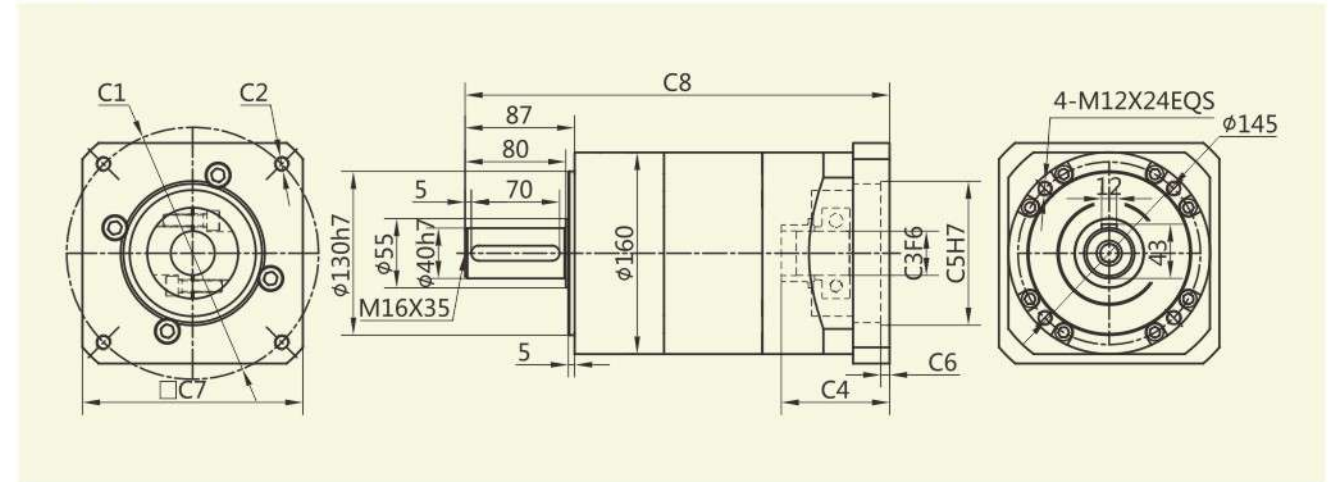

适配电机输入接口尺寸(左端为输入尺寸)
Adapter motor input interface size (The left end is the input size)

尺寸 Size	C1	C2	C3	C4	C5	C6	C7	C8
PLE-160-L2	$\phi 130$	4-M8	$\phi 22$	62	$\phi 95$	7	142	313
	$\phi 145$	4-M8	$\phi 22/\phi 24$	62	$\phi 110$	7	142	313
	$\phi 165$	4-M10	$\phi 32$	62	$\phi 130$	7	142	313
	$\phi 200$	4-M12	$\phi 35$	86	$\phi 114.3$	7	175	337
	$\phi 200$	4-M12	$\phi 35$	117	$\phi 114.3$	7	175	368
	$\phi 215$	4-M12	$\phi 38/\phi 42$	86	$\phi 180$	7	190	337

PLE-160-L3

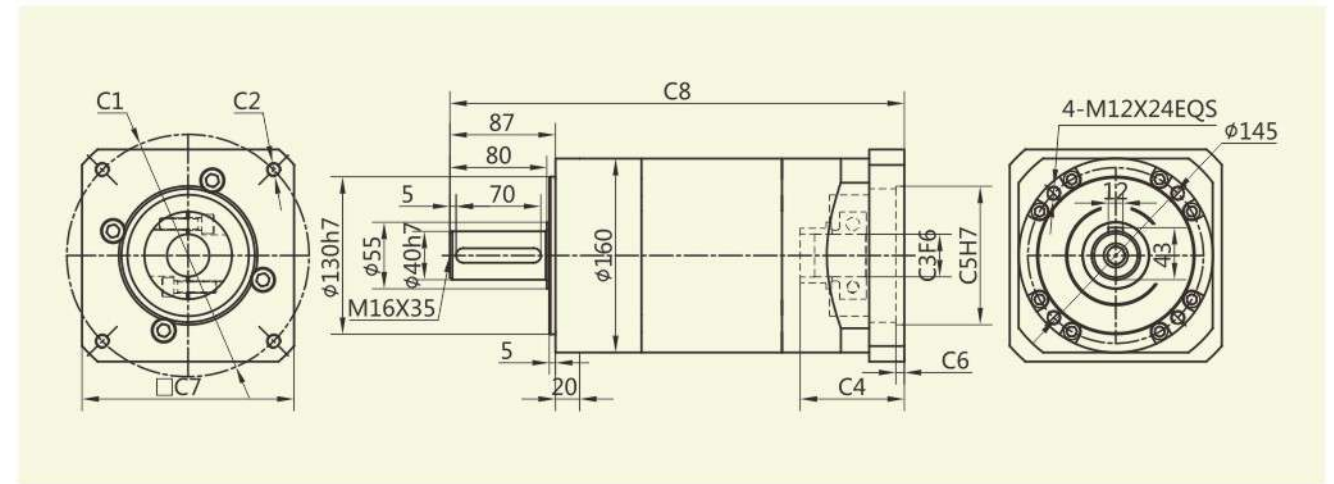

适配电机输入接口尺寸(左端为输入尺寸)
Adapter motor input interface size (The left end is the input size)

尺寸 Size	C1	C2	C3	C4	C5	C6	C7	C8
PLE-160-L3	$\phi 130$	4-M8	$\phi 22$	62	$\phi 95$	7	142	351
	$\phi 145$	4-M8	$\phi 22/\phi 24$	62	$\phi 110$	7	142	351
	$\phi 165$	4-M10	$\phi 32$	62	$\phi 130$	7	142	351
	$\phi 200$	4-M12	$\phi 35$	86	$\phi 114.3$	7	175	375
	$\phi 200$	4-M12	$\phi 35$	117	$\phi 114.3$	7	175	406
	$\phi 215$	4-M12	$\phi 38/\phi 42$	86	$\phi 180$	7	190	375

- ✓ ZPLF060
- ✓ ZPLF090
- ✓ ZPLF120



ZPLF

Series

ZPLF系列减速机核心特性

The Core Characteristics of ZPLF Series Reducer

- 1 采用直齿齿轮传动，经渗碳淬火处理，齿向齿廓修形处理，确保运行平稳，噪音小；
- 2 结构简单，可大批量生产，且交货期快性价比高；
- 3 减速机种类齐全，可以满足市场上绝大多数减速机的配合。

- 1 Adopt straight tooth gear transmission, through carburizing and quenching treatment, tooth profile modification treatment, ensure smooth operation, low noise.
- 2 Simple structure, mass production, and fast delivery time and high cost performance.
- 3 Reducer has a complete range, which can meet the needs of most reducer in the market.

减速机性能资料

Gear box performance information

型号 Model	单位 Unit	ZPLF060	ZPLF090	ZPLF120	减速比 Ratio	Stage	
额定输出扭矩 Rated output torque	N·m	16.5	60	148	3	1	
		27	86	222	4		
		27	94.5	235	5		
		19.5	64	158	7		
		8.5	39.5	93	10		
			96	250	12		
			96	250	15	2	
		30	96	250	16		
		30	96	250	20		
		33	105.5	264	25		
		30	96	250	28		
		33	105.5	264	35		
			30	96	250	40	3
			33	105.5	264	50	
			21.5	71.5	177	70	
			37.5	120	310	64	
			37.5	120	310	80	
			37.5	120	310	100	
			41.0	132.5	329	125	
			37.5	120	310	140	
	41.0	132.5	329	175			
	37.5	120	310	200			
	41.0	132.5	329	250			
	37.5	120	310	280			
	41.0	132.5	329	350			
故障停滞扭矩 Emergency stop torque	N·m	2倍额定输出扭矩 2 times Rated output torque					
额定输入转速 Norminal input speed	rmp	3000	3000	2000			
最大输入转速 Maximum input speed	rmp	6000	6000	3500			
最大径向力 Maximum radial force	N	170	1020	2230			
最大轴向力 Maximum axial force	N	120	850	1550			
效率 Efficiency	%	Single [97%]		Double [95%]			
平均寿命 Average lifetime	h	20000					
重量 Weight	kg	2.2	4.7	11.5		1	
		2.5	5.3	13.5		2	
		2.8	5.9	15.7		3	

减速机性能资料 Gear box performance information

型号 Model	单位 Unit	ZPLF060	ZPLF090	ZPLF120	减速比 Ratio	Stage
转动惯量 Moment of inertia	kgcm ²	0.107	0.4	1.65	3	1
		0.094	0.309	1.22	4	
		0.092	0.291	1.15	5	
		0.091	0.285	1.13	7	
		0.091	0.283	1.11	10	
			0.4	1.65	12	2
			0.309	1.65	15	
		0.094	0.291	1.22	16	
		0.092	0.291	1.15	20	
		0.092	0.291	1.15	25	
		0.091	0.285	1.13	28	
		0.091	0.285	1.13	35	
		0.091	0.2835	1.11	40	
		0.091	0.283	1.11	50	
		0.091	0.283	1.11	70	
		0.092	0.291	1.15	64	3
		0.092	0.291	1.15	80	
		0.092	0.291	1.15	100	
		0.092	0.291	1.15	125	
		0.091	0.291	1.13	140	
0.091	0.291	1.13	175			
0.091	0.283	1.11	200			
0.091	0.283	1.11	250			
0.091	0.283	1.11	280			
0.091	0.283	1.11	350			
噪音 Noise	dB	60	65	68		
润滑 Lubricating		合成油脂润滑 Synthetic grease lubrication				
防护等级 levels of protection		IP65				

外形尺寸图表 Outline dimensional

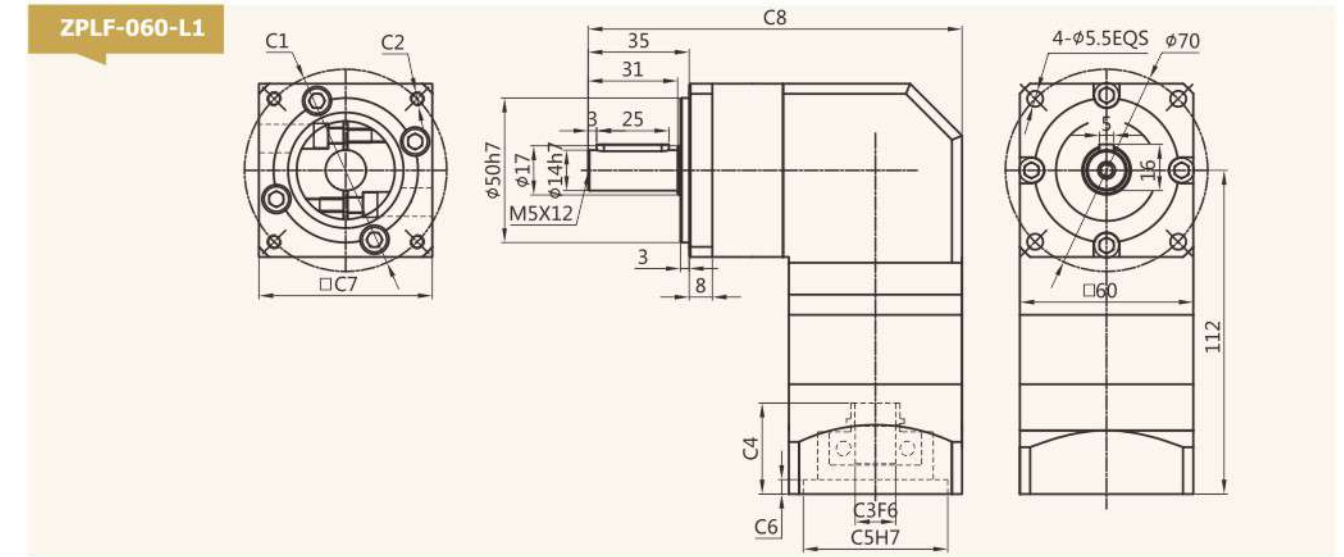

适配电机输入接口尺寸(左端为输入尺寸)
Adapter motor input interface size (The left end is the input size)

尺寸 Size	C1	C2	C3	C4	C5	C6	C7	C8
ZPLF-060-L1	□47.14	4-M4	Φ8	31.5	Φ38.1	5.0	60	129.5
	Φ46	4-M4	Φ8	31.5	Φ30	5.0	60	129.5
	Φ45	4-M3	Φ8	31.5	Φ30	5.0	60	129.5
	Φ70	4-M4/4-M5	Φ14	31.5	Φ50	5.0	60	129.5

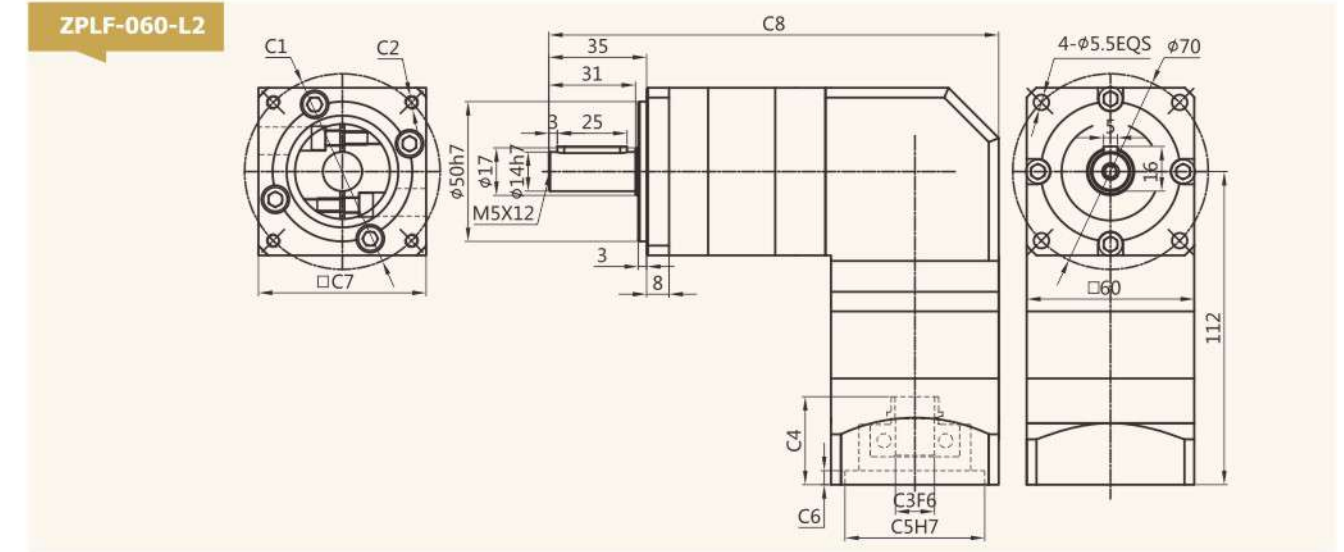

适配电机输入接口尺寸(左端为输入尺寸)
Adapter motor input interface size (The left end is the input size)

尺寸 Size	C1	C2	C3	C4	C5	C6	C7	C8
ZPLF-060-L2	□47.14	4-M4	Φ8	31.5	Φ38.1	5.0	60	161
	Φ46	4-M4	Φ8	31.5	Φ30	5.0	60	161
	Φ45	4-M3	Φ8	31.5	Φ30	5.0	60	161
	Φ70	4-M4/4-M5	Φ14	31.5	Φ50	5.0	60	161

外形尺寸图表
Outline dimensional

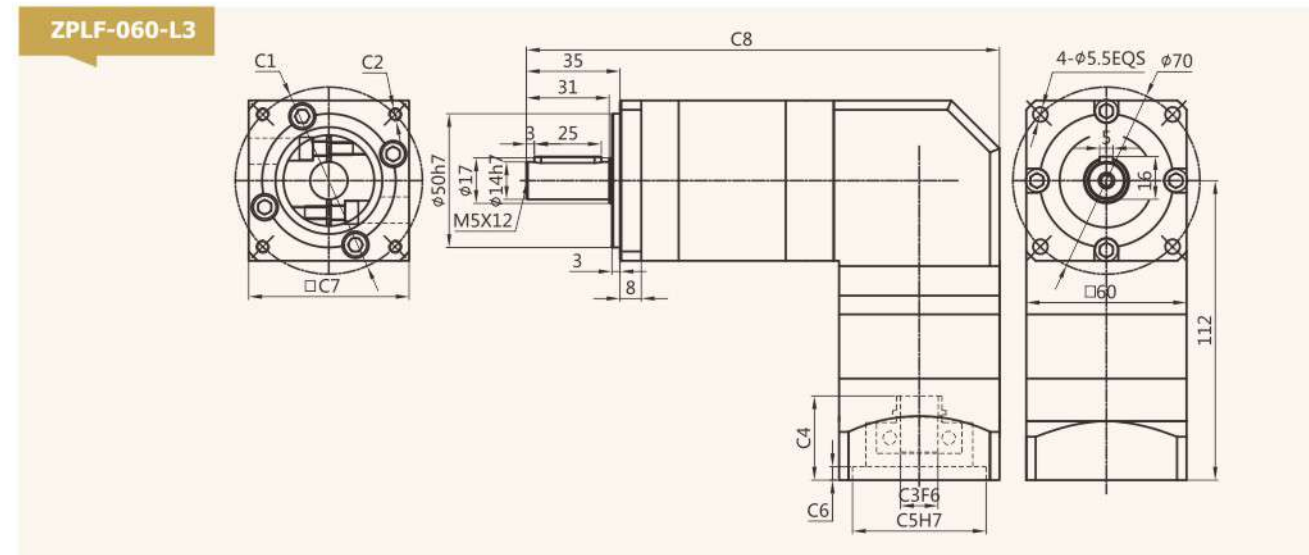

适配电机输入接口尺寸(左端为输入尺寸)
Adapter motor input interface size (The left end is the input size)

尺寸 Size	C1	C2	C3	C4	C5	C6	C7	C8
ZPLF-060-L3	□47.14	4-M4	Φ8	31.5	Φ38.1	5.0	60	177
	Φ46	4-M4	Φ8	31.5	Φ30	5.0	60	177
	Φ45	4-M3	Φ8	31.5	Φ30	5.0	60	177
	Φ70	4-M4/4-M5	Φ14	31.5	Φ50	5.0	60	177

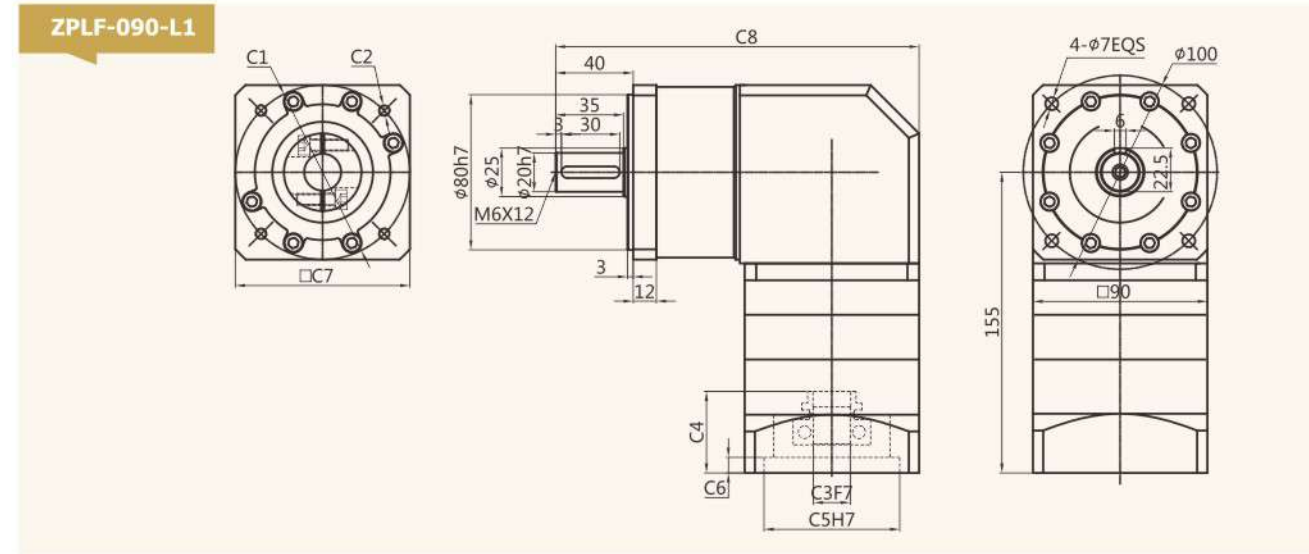

适配电机输入接口尺寸(左端为输入尺寸)
Adapter motor input interface size (The left end is the input size)

尺寸 Size	C1	C2	C3	C4	C5	C6	C7	C8
ZPLF-090-L1	Φ70	4-M4/4-M5	Φ14	42	Φ50	8.0	80	187.5
	□69.6	4-M6	Φ14	42	Φ73	8.0	80	187.5
	Φ90	4-M5/4-M6	Φ19	42	Φ70	8.0	80	187.5

外形尺寸图表
Outline dimensional

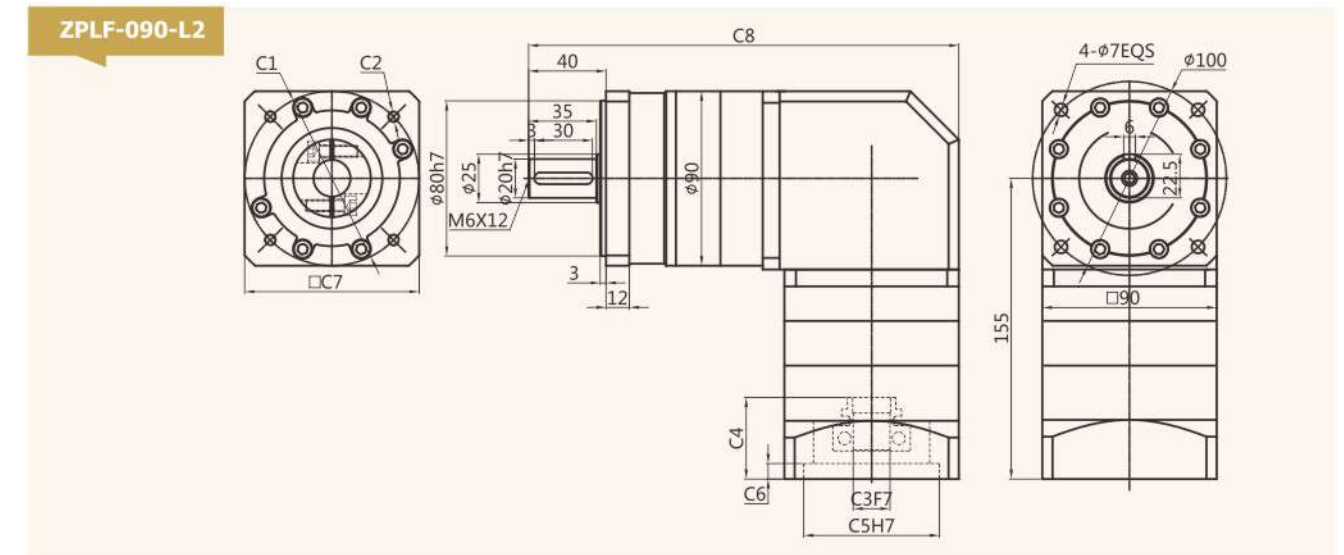

适配电机输入接口尺寸(左端为输入尺寸)
Adapter motor input interface size (The left end is the input size)

尺寸 Size	C1	C2	C3	C4	C5	C6	C7	C8
ZPLF-090-L2	Φ70	4-M4/4-M5	Φ14	42	Φ50	8.0	80	222
	□69.6	4-M6	Φ14	42	Φ73	8.0	80	222
	Φ90	4-M5/4-M6	Φ19	42	Φ70	8.0	80	222

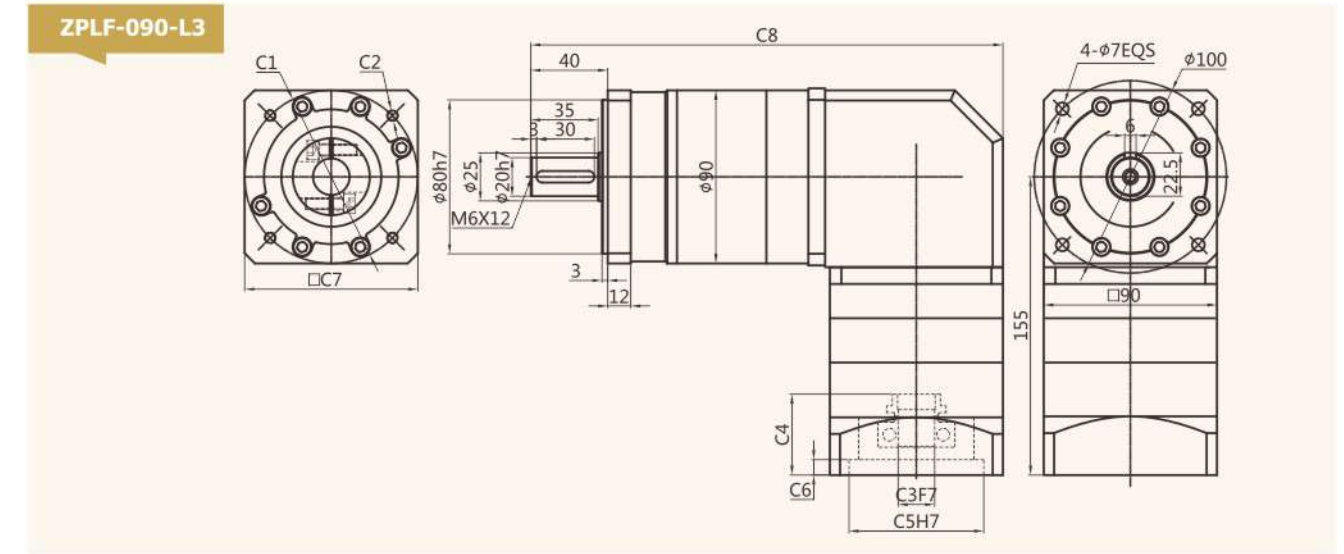

适配电机输入接口尺寸(左端为输入尺寸)
Adapter motor input interface size (The left end is the input size)

尺寸 Size	C1	C2	C3	C4	C5	C6	C7	C8
ZPLF-090-L3	Φ70	4-M4/4-M5	Φ14	42	Φ50	8.0	90	245.5
	□69.6	4-M6	Φ14	42	Φ73	8.0	90	245.5
	Φ90	4-M5/4-M6	Φ19	42	Φ70	8.0	90	245.5

外形尺寸图表
Outline dimensional

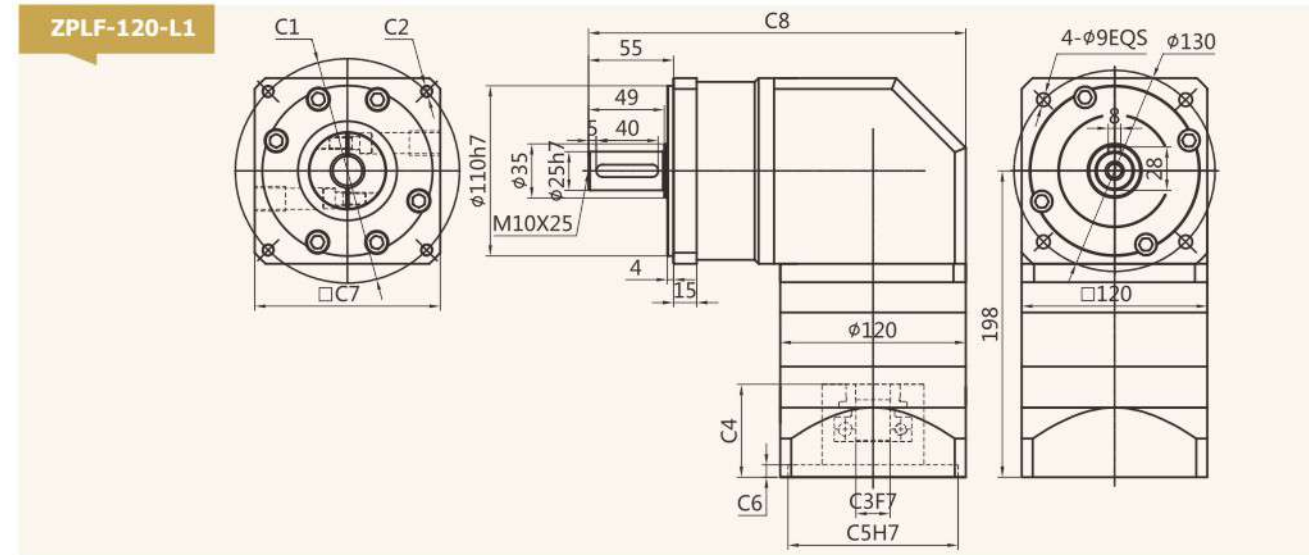

适配电机输入接口尺寸(左端为输入尺寸)
Adapter motor input interface size (The left end is the input size)

尺寸 Size	C1	C2	C3	C4	C5	C6	C7	C8
ZPLF-120-L1	Φ90	4-M5/4-M6	Φ19	47	Φ70	8	90	244
	Φ115	4-M8	Φ19/Φ22	60	Φ95	8	130	244
	Φ130	4-M8	Φ19/Φ22	60	Φ95	8	130	244
	Φ145	4-M8	Φ19/Φ22/Φ24	60	Φ110	8	180	244

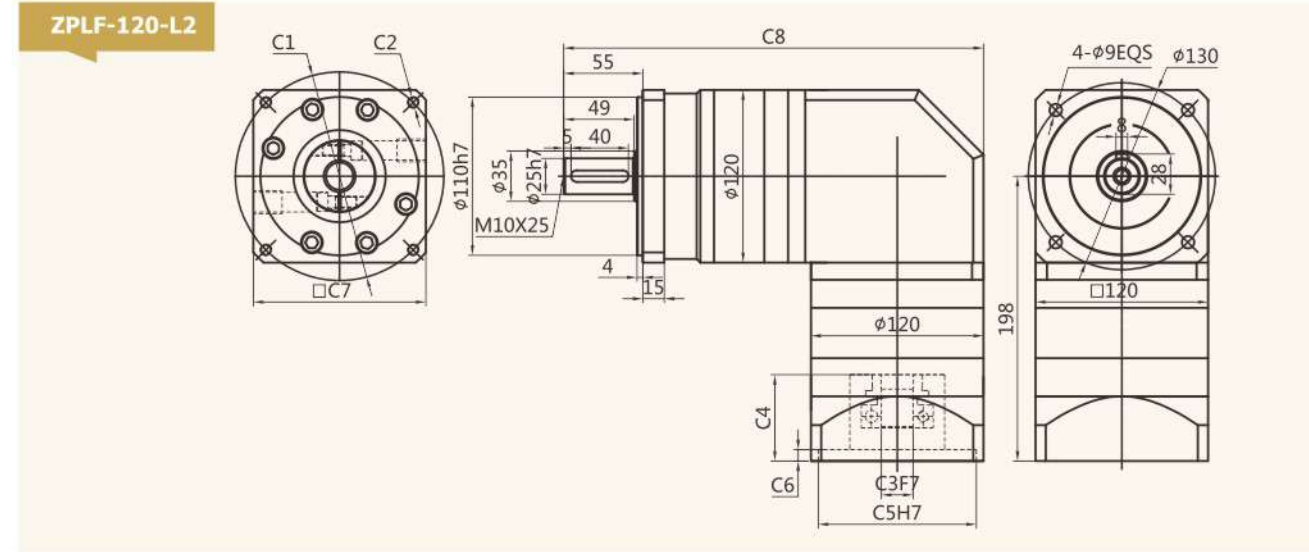

适配电机输入接口尺寸(左端为输入尺寸)
Adapter motor input interface size (The left end is the input size)

尺寸 Size	C1	C2	C3	C4	C5	C6	C7	C8
ZPLF-120-L2	Φ90	4-M5/4-M6	Φ19	47	Φ70	8	90	292
	Φ115	4-M8	Φ19/Φ22	60	Φ95	8	130	292
	Φ130	4-M8	Φ19/Φ22	60	Φ95	8	130	292
	Φ145	4-M8	Φ19/Φ22/Φ24	60	Φ110	8	180	292

外形尺寸图表
Outline dimensional

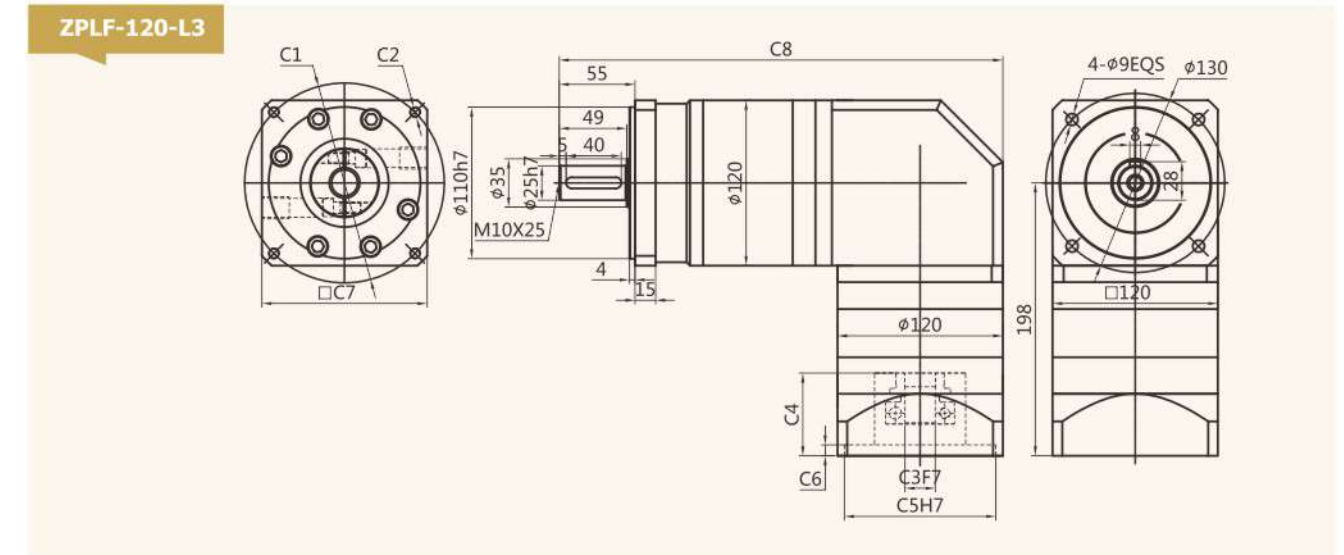

适配电机输入接口尺寸(左端为输入尺寸)
Adapter motor input interface size (The left end is the input size)

尺寸 Size	C1	C2	C3	C4	C5	C6	C7	C8
ZPLF-120-L3	Φ90	4-M5/4-M6	Φ19	47	Φ70	8	90	322
	Φ115	4-M8	Φ19/Φ22	60	Φ95	8	130	322
	Φ130	4-M8	Φ19/Φ22	60	Φ95	8	130	322
	Φ145	4-M8	Φ19/Φ22/Φ24	60	Φ110	8	180	322

- ✓ ZPLE060
- ✓ ZPLE090
- ✓ ZPLE120



ZPLE Series

ZPLE系列减速机核心特性

The Core Characteristics of ZPLE Series Reducer

- 1 采用直齿齿轮传动，经渗碳淬火处理，齿向齿廓修形处理，确保运行平稳，噪音小；
- 2 结构简单，可大批量生产，且交货期快性价比高；
- 3 减速机种类齐全，可以满足市场上绝大多数减速机的配合。

- 1 Adopt straight tooth gear transmission, through carburizing and quenching treatment, tooth profile modification treatment, ensure smooth operation, low noise.
- 2 Simple structure, mass production, and fast delivery time and high cost performance.
- 3 Reducer has a complete range, which can meet the needs of most reducer in the market.

减速机性能资料

Gear box performance information

型号 Model	单位 Unit	ZPLE060	ZPLE090	ZPLE120	减速比 Ratio	Stage
额定输出扭矩 Rated output torque	N·m	16.5	60	148	3	1
		27	86	222	4	
		27	94.5	235	5	
		19.5	64	158	7	
		8.5	39.5	93	10	
			96	250	12	2
			96	250	15	
		30	96	250	16	
		30	96	250	20	
		33	105.5	264	25	
		30	96	250	28	3
		33	105.5	264	35	
		30	96	250	40	
		33	105.5	264	50	
		21.5	71.5	177	70	
		37.5	120	310	64	
		37.5	120	310	80	
		37.5	120	310	100	
		41.0	132.5	329	125	
		37.5	120	310	140	
41.0	132.5	329	175			
37.5	120	310	200			
41.0	132.5	329	250			
37.5	120	310	280			
41.0	132.5	329	350			
故障停滞扭矩 Emergency stop torque	N·m	2倍额定输出扭矩 2 times Rated output torque				
额定输入转速 Norminal input speed	rmp	3000	3000	2000		
最大输入转速 Maximum input speed	rmp	6000	6000	3500		
最大径向力 Maximum radial force	N	170	1020	2230		
最大轴向力 Maximum axial force	N	120	850	1550		
效率 Efficiency	%	Single [97%]		Double [95%]		
平均寿命 Average lifetime	h	20000				
重量 Weight	kg	2.2	4.7	11.5		1
		2.5	5.3	13.5		2
		2.8	5.9	15.7		3

减速机性能资料 Gear box performance information

型号 Model	单位 Unit	ZPLE060	ZPLE090	ZPLE120	减速比 Ratio	Stage
转动惯量 Moment of inertia	kgcm ²	0.107	0.4	1.65	3	1
		0.094	0.309	1.22	4	
		0.092	0.291	1.15	5	
		0.091	0.285	1.13	7	
		0.091	0.283	1.11	10	
			0.4	1.65	12	2
			0.309	1.65	15	
		0.094	0.291	1.22	16	
		0.092	0.291	1.15	20	
		0.092	0.291	1.15	25	
		0.091	0.285	1.13	28	
		0.091	0.285	1.13	35	
		0.091	0.2835	1.11	40	
		0.091	0.283	1.11	50	
		0.091	0.283	1.11	70	
		0.092	0.291	1.15	64	3
		0.092	0.291	1.15	80	
		0.092	0.291	1.15	100	
		0.092	0.291	1.15	125	
		0.091	0.291	1.13	140	
0.091	0.291	1.13	175			
0.091	0.283	1.11	200			
0.091	0.283	1.11	250			
0.091	0.283	1.11	280			
0.091	0.283	1.11	350			
噪音 Noise	dB	60	65	68		
润滑 Lubricating		合成油脂润滑 Synthetic grease lubrication				
防护等级 levels of protection		IP65				

外形尺寸图表 Outline dimensional

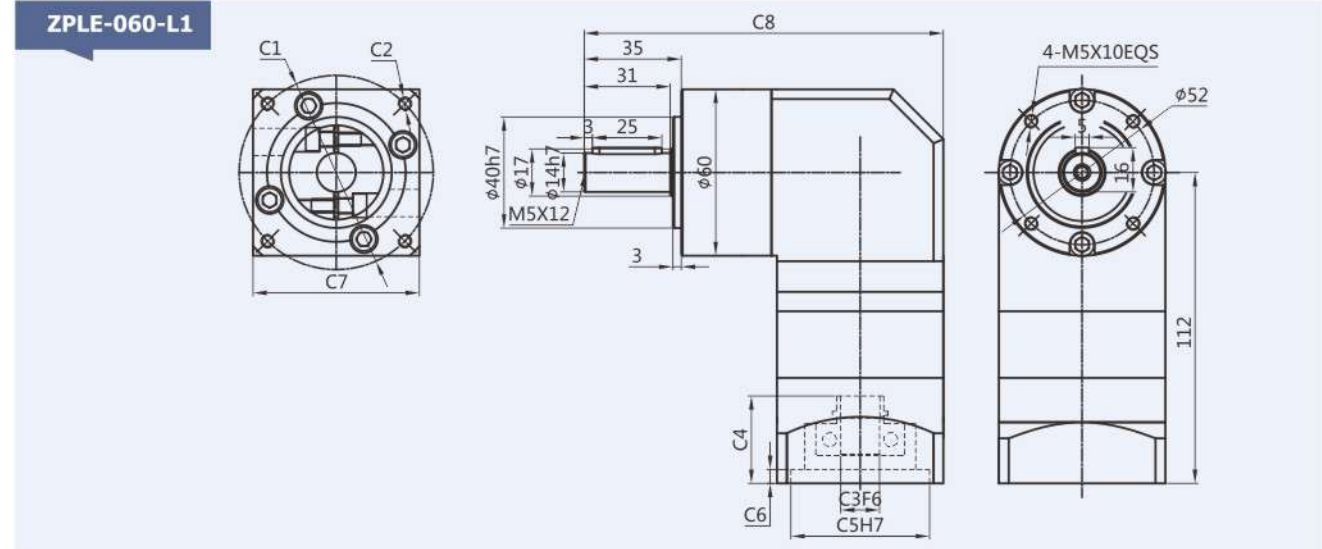

适配电机输入接口尺寸(左端为输入尺寸)
Adapter motor input interface size (The left end is the input size)

尺寸 Size	C1	C2	C3	C4	C5	C6	C7	C8
ZPLE-060-L1	□47.14	4-M4	Φ8	31.5	Φ38.1	5.0	60	129.5
	Φ46	4-M4	Φ8	31.5	Φ30	5.0	60	129.5
	Φ45	4-M3	Φ8	31.5	Φ30	5.0	60	129.5
	Φ70	4-M4/4-M5	Φ14	31.5	Φ50	5.0	60	129.5

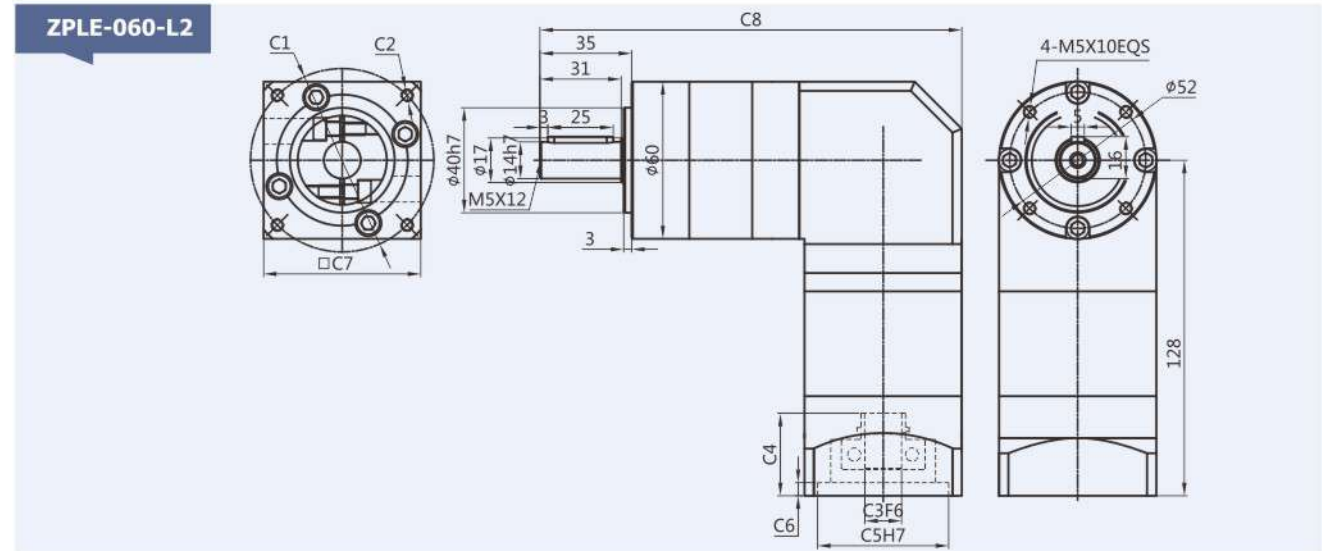

适配电机输入接口尺寸(左端为输入尺寸)
Adapter motor input interface size (The left end is the input size)

尺寸 Size	C1	C2	C3	C4	C5	C6	C7	C8
ZPLE-060-L2	□47.14	4-M4	Φ8	31.5	Φ38.1	5.0	60	161
	Φ46	4-M4	Φ8	31.5	Φ30	5.0	60	161
	Φ45	4-M3	Φ8	31.5	Φ30	5.0	60	161
	Φ70	4-M4/4-M5	Φ14	31.5	Φ50	5.0	60	161

外形尺寸图表

Outline dimensional

ZPLE-060-L3

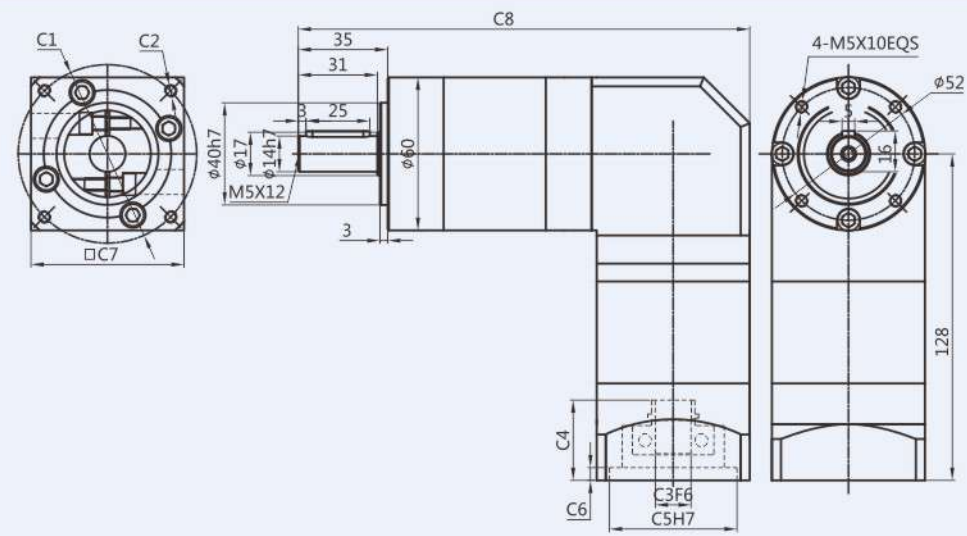

适配电机输入接口尺寸(左端为输入尺寸)

Adapter motor input interface size (The left end is the input size)

尺寸 Size	C1	C2	C3	C4	C5	C6	C7	C8
ZPLE-060-L3	$\square 47.14$	4-M4	$\phi 8$	31.5	$\phi 38.1$	5.0	60	177
	$\phi 46$	4-M4	$\phi 8$	31.5	$\phi 30$	5.0	60	177
	$\phi 45$	4-M3	$\phi 8$	31.5	$\phi 30$	5.0	60	177
	$\phi 70$	4-M4/4-M5	$\phi 14$	31.5	$\phi 50$	5.0	60	177

ZPLE-090-L1

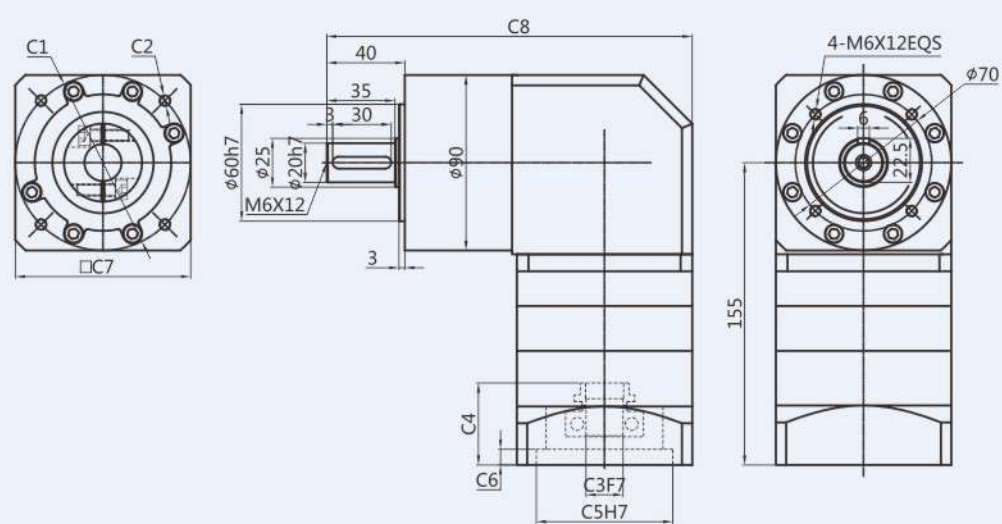

适配电机输入接口尺寸(左端为输入尺寸)

Adapter motor input interface size (The left end is the input size)

尺寸 Size	C1	C2	C3	C4	C5	C6	C7	C8
ZPLE-090-L1	$\phi 70$	4-M4/4-M5	$\phi 14$	42	$\phi 50$	8.0	80	187.5
	$\square 69.6$	4-M6	$\phi 14$	42	$\phi 73$	8.0	80	187.5
	$\phi 90$	4-M5/4-M6	$\phi 19$	42	$\phi 70$	8.0	80	187.5

外形尺寸图表

Outline dimensional

ZPLE-090-L2

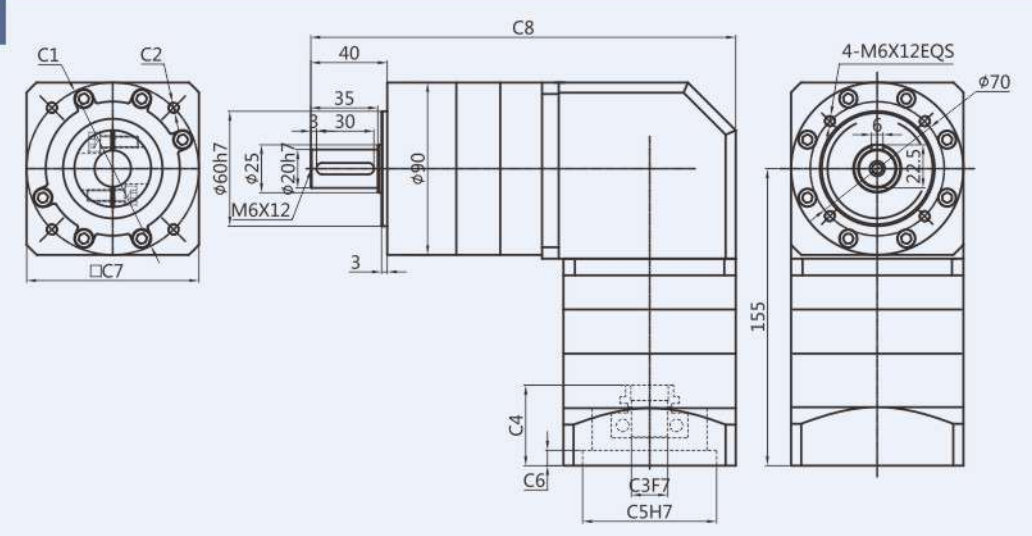

适配电机输入接口尺寸(左端为输入尺寸)

Adapter motor input interface size (The left end is the input size)

尺寸 Size	C1	C2	C3	C4	C5	C6	C7	C8
ZPLE-090-L2	$\phi 70$	4-M4/4-M5	$\phi 14$	42	$\phi 50$	8.0	80	222
	$\square 69.6$	4-M6	$\phi 14$	42	$\phi 73$	8.0	80	222
	$\phi 90$	4-M5/4-M6	$\phi 19$	42	$\phi 70$	8.0	80	222

ZPLE-090-L3

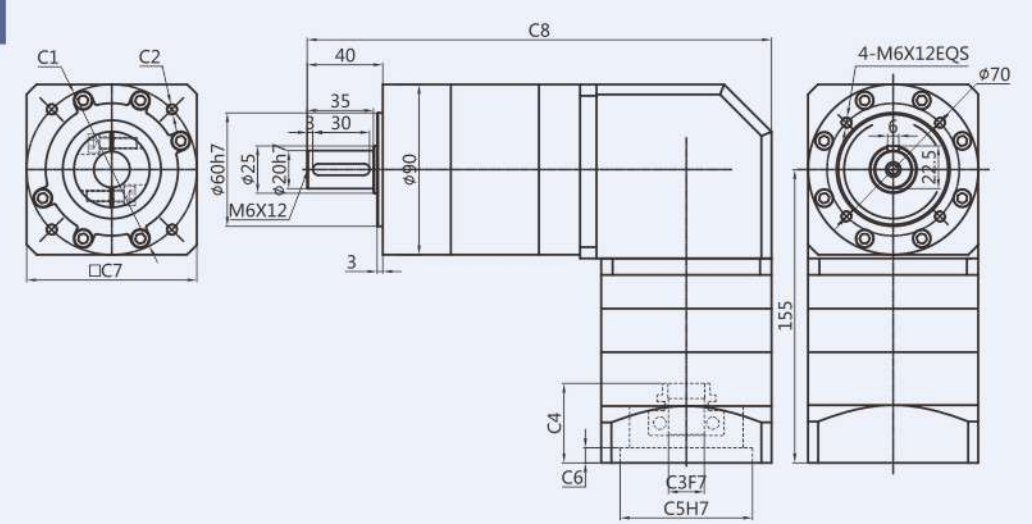

适配电机输入接口尺寸(左端为输入尺寸)

Adapter motor input interface size (The left end is the input size)

尺寸 Size	C1	C2	C3	C4	C5	C6	C7	C8
ZPLE-090-L3	$\phi 70$	4-M4/4-M5	$\phi 14$	42	$\phi 50$	8.0	90	245.5
	$\square 69.6$	4-M6	$\phi 14$	42	$\phi 73$	8.0	90	245.5
	$\phi 90$	4-M5/4-M6	$\phi 19$	42	$\phi 70$	8.0	90	245.5

外形尺寸图表

Outline dimensional

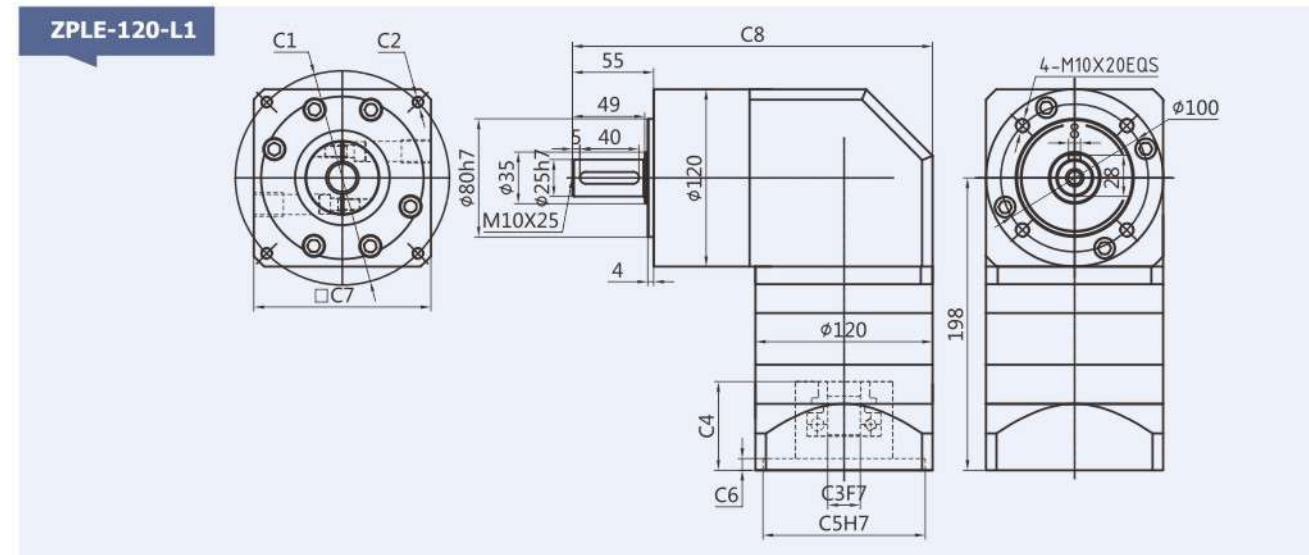

适配电机输入接口尺寸(左端为输入尺寸)

Adapter motor input interface size (The left end is the input size)

尺寸 Size	C1	C2	C3	C4	C5	C6	C7	C8
ZPLE-120-L1	Φ90	4-M5/4-M6	Φ19	47	Φ70	8	90	244
	Φ115	4-M8	Φ19/Φ22	60	Φ95	8	130	244
	Φ130	4-M8	Φ19/Φ22	60	Φ95	8	130	244
	Φ145	4-M8	Φ19/Φ22/Φ24	60	Φ110	8	180	244

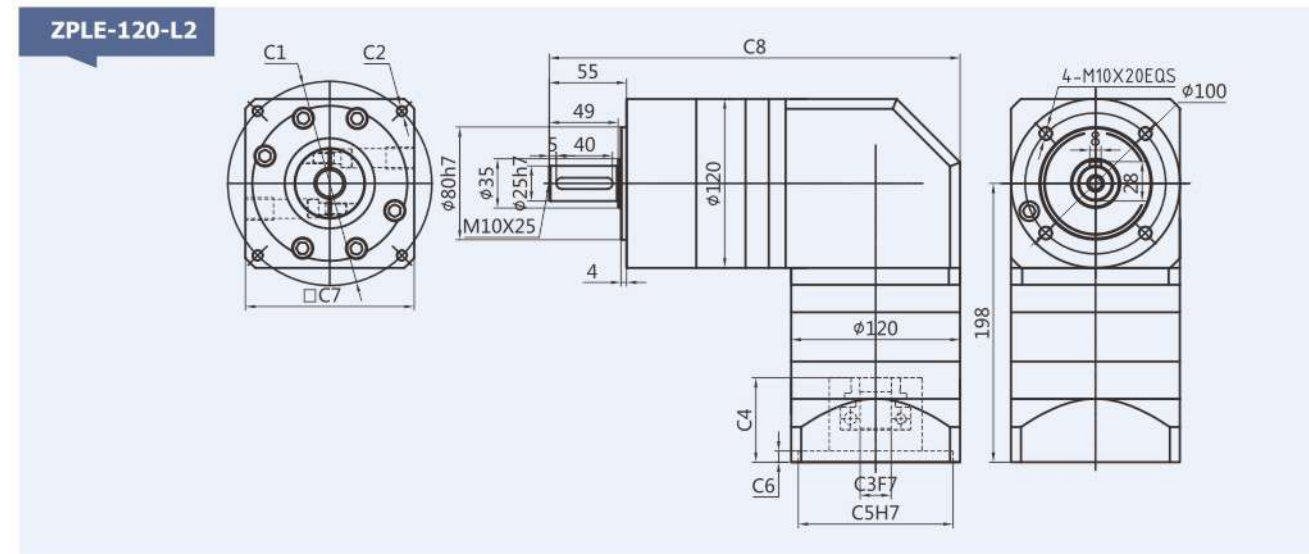

适配电机输入接口尺寸(左端为输入尺寸)

Adapter motor input interface size (The left end is the input size)

尺寸 Size	C1	C2	C3	C4	C5	C6	C7	C8
ZPLE-120-L2	Φ90	4-M5/4-M6	Φ19	47	Φ70	8	90	292
	Φ115	4-M8	Φ19/Φ22	60	Φ95	8	130	292
	Φ130	4-M8	Φ19/Φ22	60	Φ95	8	130	292
	Φ145	4-M8	Φ19/Φ22/Φ24	60	Φ110	8	180	292

外形尺寸图表

Outline dimensional

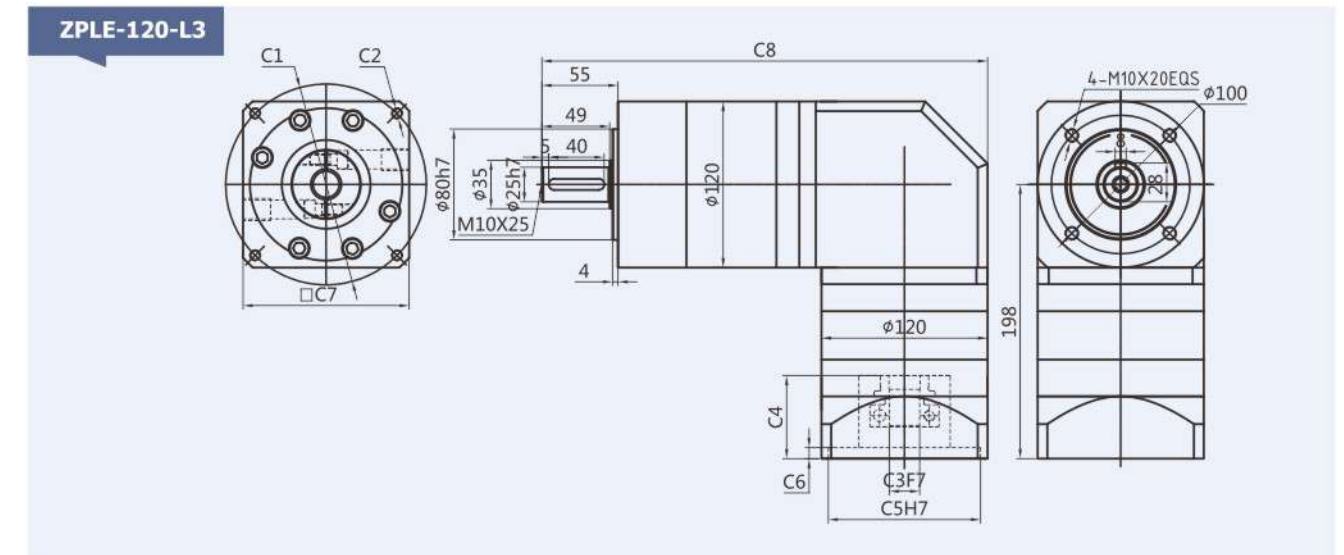

适配电机输入接口尺寸(左端为输入尺寸)

Adapter motor input interface size (The left end is the input size)

尺寸 Size	C1	C2	C3	C4	C5	C6	C7	C8
ZPLE-120-L3	Φ90	4-M5/4-M6	Φ19	47	Φ70	8	90	322
	Φ115	4-M8	Φ19/Φ22	60	Φ95	8	130	322
	Φ130	4-M8	Φ19/Φ22	60	Φ95	8	130	322
	Φ145	4-M8	Φ19/Φ22/Φ24	60	Φ110	8	180	322

减速机性能资料 Gear box performance information

型号 Model	单位 Unit	ZPLX142	ZPLF160	ZPLE160	减速比 Ratio	Stage
额定输出扭矩 Rated output torque	N·m	310	310	310	3	1
		605	605	605	4	
		420	420	420	5	
		270	270	270	8	
		680	680	680	12	2
		680	680	680	16	
		680	680	680	20	
		460	460	460	25	
		680	680	680	32	
		460	460	460	40	
		310	310	310	64	
		900	900	900	64	
		900	900	900	80	3
		900	900	900	100	
		580	580	580	125	
		580	580	580	160	
		580	580	580	200	
		900	900	900	256	
		580	580	580	320	
		400	400	400	512	
故障停滞扭矩 Emergency stop torque	N·m	2倍额定输出扭矩 2 times Rated output torque				
额定输入转速 Norminal input speed	rmp	2000	2000	2000		
最大输入转速 Maximum input speed	rmp	3500	3500	3500		
最大径向力 Maximum radial force	N	3200	3200	3200		
最大轴向力 Maximum axial force	N	3000	3000	3000		
效率 Efficiency	%	Single [97%]		Double [95%]		
平均寿命 Average lifetime	h	20000				
重量 Weight	kg	26.5	26.5	26.5		1
		31.5	31.5	31.5		2
		37.5	37.5	37.5		3

减速机性能资料 Gear box performance information

型号 Model	单位 Unit	ZPLX142	ZPLF160	ZPLE160	减速比 Ratio	Stage
转动惯量 Moment of inertia	kgcm ²	4.31	4.31	4.31	3	1
		5.15	5.15	5.15	4	
		4.93	4.93	4.93	5	
		4.84	4.84	4.84	8	
		6.31	6.31	6.31	12	2
		5.15	5.15	5.15	16	
		4.93	4.93	4.93	20	
		4.93	4.93	4.93	25	
		4.84	4.84	4.84	32	
		4.84	4.84	4.84	40	
		4.84	4.84	4.84	64	
		4.93	4.93	4.93	64	
		4.93	4.93	4.93	80	3
		4.93	4.93	4.93	100	
		4.84	4.84	4.84	125	
		4.84	4.84	4.84	160	
		4.84	4.84	4.84	200	
		4.84	4.84	4.84	256	
		4.84	4.84	4.84	320	
		4.84	4.84	4.84	512	
噪音 Noise	dB	70	70	70		
润滑 Lubricating		合成油脂润滑 Synthetic grease lubrication				
防护等级 levels of protection		IP65				

外形尺寸图表

Outline dimensional

ZPLX-142-L1

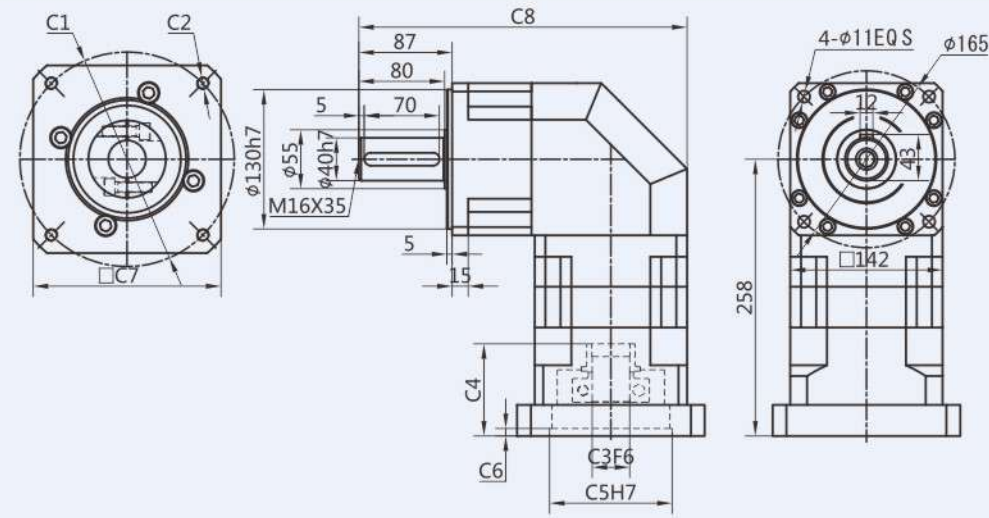

适配电机输入接口尺寸(左端为输入尺寸)

Adapter motor input interface size (The left end is the input size)

尺寸 Size	C1	C2	C3	C4	C5	C6	C7	C8
ZPLX-142-L1	Φ130	4-M8	Φ22	62	Φ95	7	142	306
	Φ145	4-M8	Φ22/Φ24	62	Φ110	7	142	306
	Φ165	4-M10	Φ32	62	Φ130	7	142	306
	Φ200	4-M12	Φ35	86	Φ114.3	7	175	306
	Φ200	4-M12	Φ35	117	Φ114.3	7	175	306
	Φ215	4-M12	Φ38/Φ42	86	Φ180	7	190	306

ZPLX-142-L2

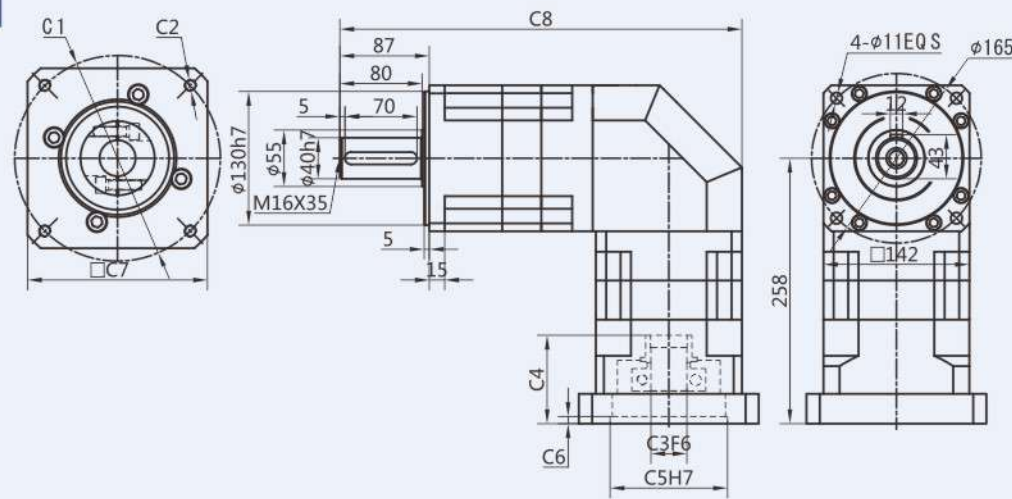

适配电机输入接口尺寸(左端为输入尺寸)

Adapter motor input interface size (The left end is the input size)

尺寸 Size	C1	C2	C3	C4	C5	C6	C7	C8
ZPLX-142-L2	Φ130	4-M8	Φ22	62	Φ95	7	142	391
	Φ145	4-M8	Φ22/Φ24	62	Φ110	7	142	391
	Φ165	4-M10	Φ32	62	Φ130	7	142	391
	Φ200	4-M12	Φ35	86	Φ114.3	7	175	391
	Φ200	4-M12	Φ35	117	Φ114.3	7	175	391
	Φ215	4-M12	Φ38/Φ42	86	Φ180	7	190	391

外形尺寸图表

Outline dimensional

ZPLX-142-L3

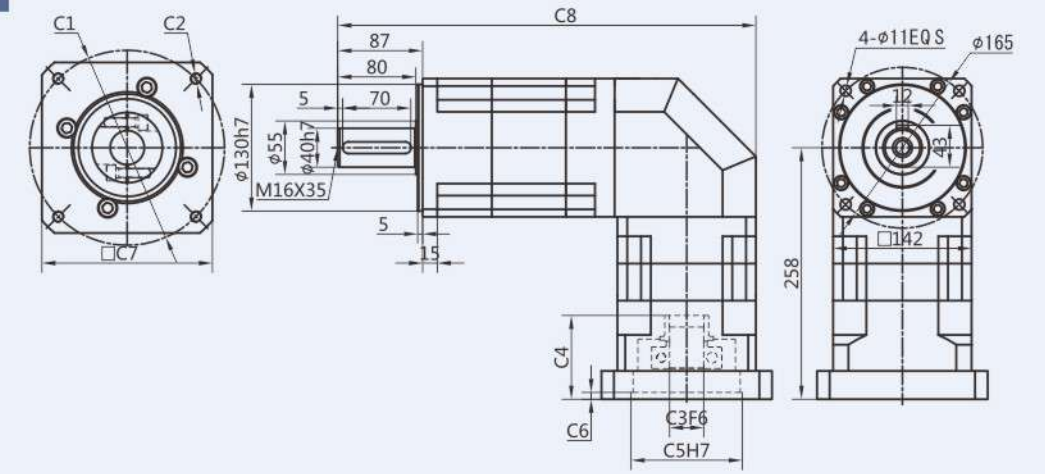

适配电机输入接口尺寸(左端为输入尺寸)

Adapter motor input interface size (The left end is the input size)

尺寸 Size	C1	C2	C3	C4	C5	C6	C7	C8
ZPLX-142-L3	Φ130	4-M8	Φ22	62	Φ95	7	142	429
	Φ145	4-M8	Φ22/Φ24	62	Φ110	7	142	429
	Φ165	4-M10	Φ32	62	Φ130	7	142	429
	Φ200	4-M12	Φ35	86	Φ114.3	7	175	429
	Φ200	4-M12	Φ35	117	Φ114.3	7	175	429
	Φ215	4-M12	Φ38/Φ42	86	Φ180	7	190	429

ZPLF-160-L1

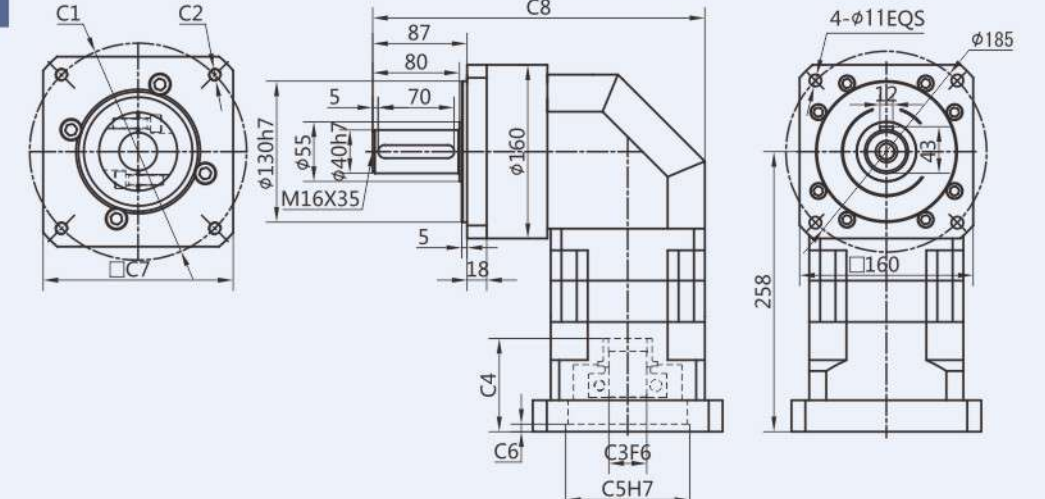

适配电机输入接口尺寸(左端为输入尺寸)

Adapter motor input interface size (The left end is the input size)

尺寸 Size	C1	C2	C3	C4	C5	C6	C7	C8
ZPLF-160-L1	Φ130	4-M8	Φ22	62	Φ95	7	142	306
	Φ145	4-M8	Φ22/Φ24	62	Φ110	7	142	306
	Φ165	4-M10	Φ32	62	Φ130	7	142	306
	Φ200	4-M12	Φ35	86	Φ114.3	7	175	306
	Φ200	4-M12	Φ35	117	Φ114.3	7	175	306
	Φ215	4-M12	Φ38/Φ42	86	Φ180	7	190	306

外形尺寸图表

Outline dimensional

ZPLF-160-L2

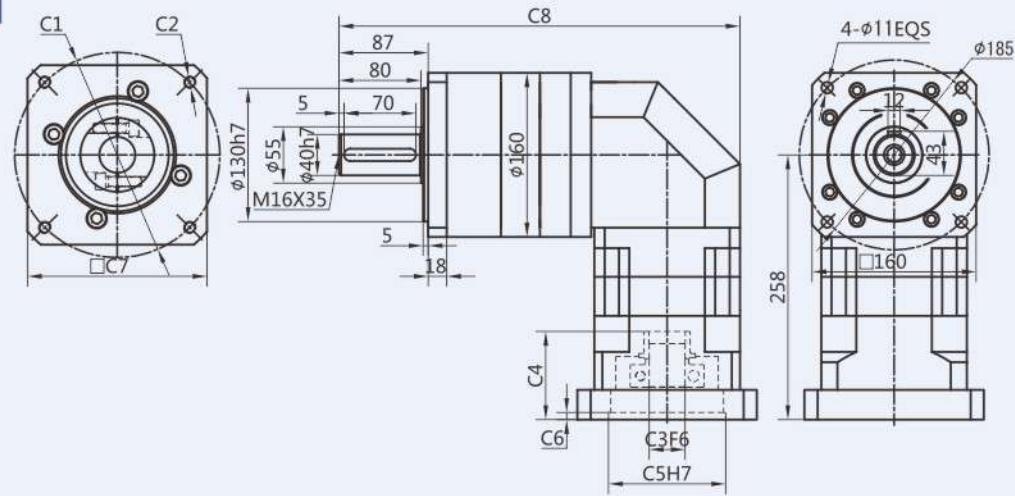

适配电机输入接口尺寸(左端为输入尺寸)

Adapter motor input interface size (The left end is the input size)

尺寸 Size	C1	C2	C3	C4	C5	C6	C7	C8
ZPLF-160-L2	Φ130	4-M8	Φ22	62	Φ95	7	142	391
	Φ145	4-M8	Φ22/Φ24	62	Φ110	7	142	391
	Φ165	4-M10	Φ32	62	Φ130	7	142	391
	Φ200	4-M12	Φ35	86	Φ114.3	7	175	391
	Φ200	4-M12	Φ35	117	Φ114.3	7	175	391
	Φ215	4-M12	Φ38/Φ42	86	Φ180	7	190	391

ZPLF-160-L3

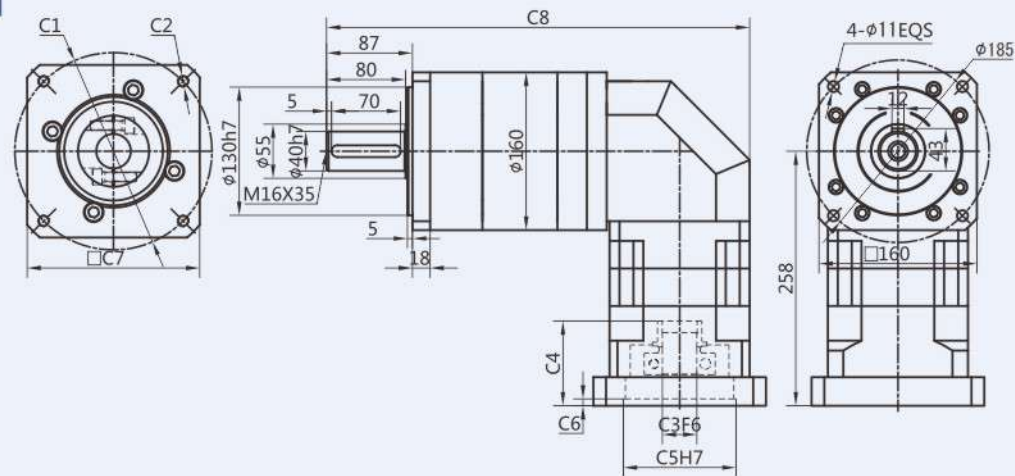

适配电机输入接口尺寸(左端为输入尺寸)

Adapter motor input interface size (The left end is the input size)

尺寸 Size	C1	C2	C3	C4	C5	C6	C7	C8
ZPLF-160-L3	Φ130	4-M8	Φ22	62	Φ95	7	142	429
	Φ145	4-M8	Φ22/Φ24	62	Φ110	7	142	429
	Φ165	4-M10	Φ32	62	Φ130	7	142	429
	Φ200	4-M12	Φ35	86	Φ114.3	7	175	429
	Φ200	4-M12	Φ35	117	Φ114.3	7	175	429
	Φ215	4-M12	Φ38/Φ42	86	Φ180	7	190	429

外形尺寸图表

Outline dimensional

ZPLE-160-L1

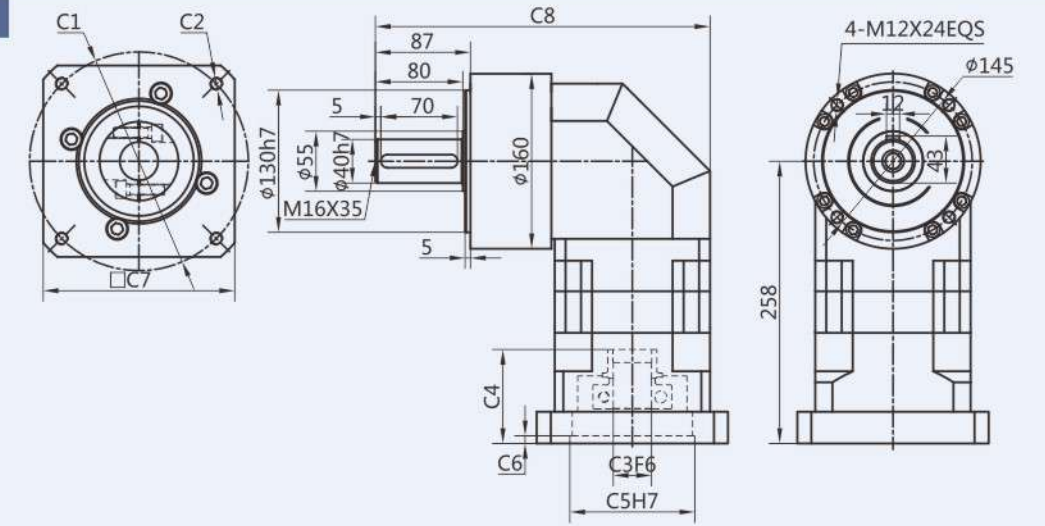

适配电机输入接口尺寸(左端为输入尺寸)

Adapter motor input interface size (The left end is the input size)

尺寸 Size	C1	C2	C3	C4	C5	C6	C7	C8
ZPLE-160-L1	Φ130	4-M8	Φ22	62	Φ95	7	142	306
	Φ145	4-M8	Φ22/Φ24	62	Φ110	7	142	306
	Φ165	4-M10	Φ32	62	Φ130	7	142	306
	Φ200	4-M12	Φ35	86	Φ114.3	7	175	306
	Φ200	4-M12	Φ35	117	Φ114.3	7	175	306
	Φ215	4-M12	Φ38/Φ42	86	Φ180	7	190	306

ZPLE-160-L2

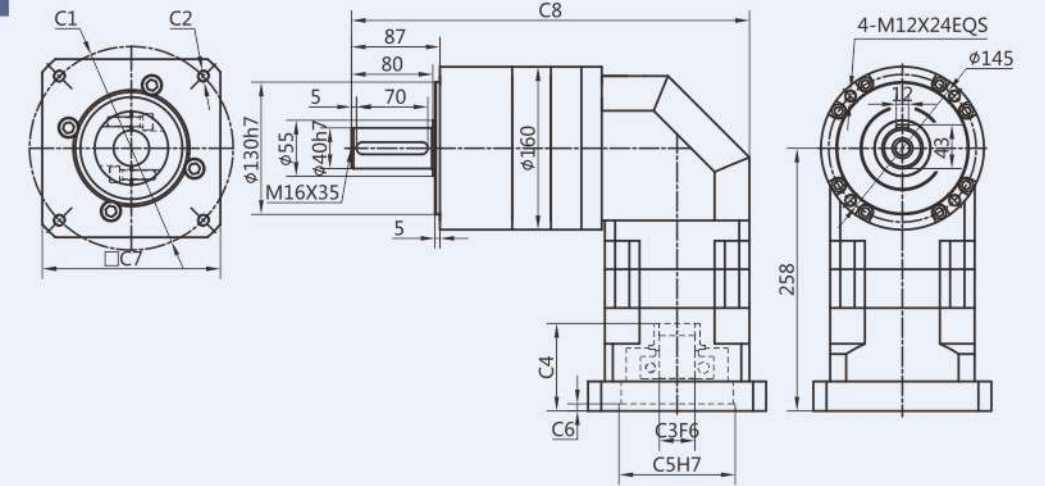

适配电机输入接口尺寸(左端为输入尺寸)

Adapter motor input interface size (The left end is the input size)

尺寸 Size	C1	C2	C3	C4	C5	C6	C7	C8
ZPLE-160-L2	Φ130	4-M8	Φ22	62	Φ95	7	142	391
	Φ145	4-M8	Φ22/Φ24	62	Φ110	7	142	391
	Φ165	4-M10	Φ32	62	Φ130	7	142	391
	Φ200	4-M12	Φ35	86	Φ114.3	7	175	391
	Φ200	4-M12	Φ35	117	Φ114.3	7	175	391
	Φ215	4-M12	Φ38/Φ42	86	Φ180	7	190	391

外形尺寸图表

Outline dimensional

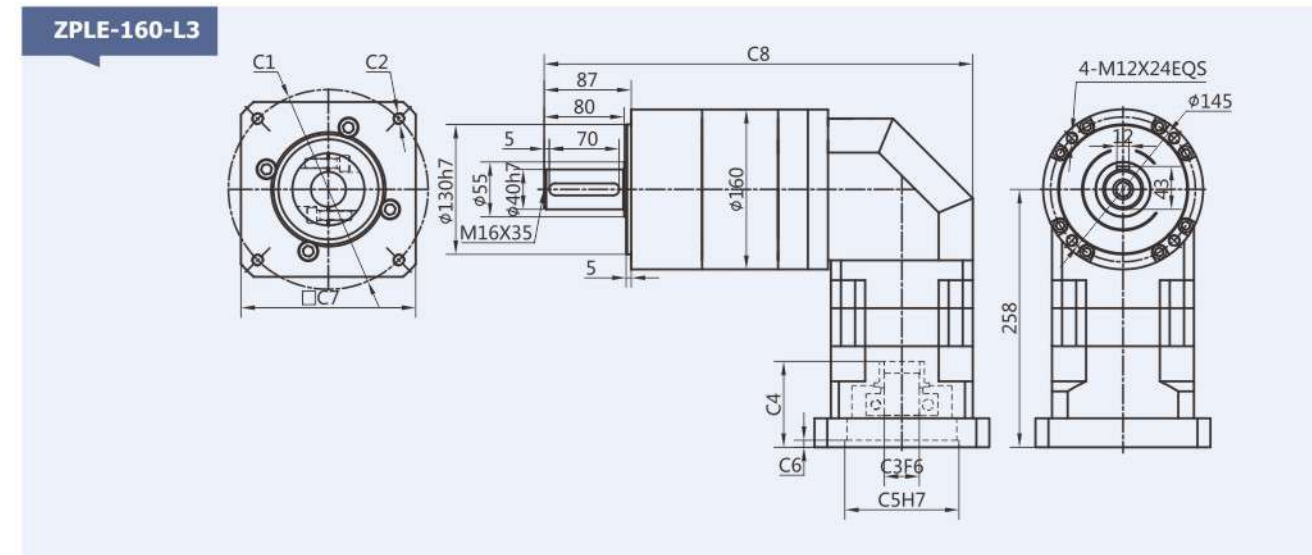

适配电机输入接口尺寸(左端为输入尺寸)
Adapter motor input interface size (The left end is the input size)

尺寸 Size	C1	C2	C3	C4	C5	C6	C7	C8
ZPLE-160-L3	Φ130	4-M8	Φ22	62	Φ95	7	142	429
	Φ145	4-M8	Φ22/Φ24	62	Φ110	7	142	429
	Φ165	4-M10	Φ32	62	Φ130	7	142	429
	Φ200	4-M12	Φ35	86	Φ114.3	7	175	429
	Φ200	4-M12	Φ35	117	Φ114.3	7	175	429
	Φ215	4-M12	Φ38/Φ42	86	Φ180	7	190	429

- PLFK060
- PLFK090
- PLFK120



PLFK Series

PLFK系列减速机核心特性

The Core Characteristics of PLFK Series Reducer

- 1 采用直齿齿轮传动，经渗碳淬火处理，齿向齿廓修形处理，确保运行平稳，噪音小；
- 2 结构简单，可大批量生产，且交货期快性价比高；
- 3 减速机种类齐全，可以满足市场上绝大多数减速机的配合。

- 1 Adopt straight tooth gear transmission, through carburizing and quenching treatment, tooth profile modification treatment, ensure smooth operation, low noise.
- 2 Simple structure, mass production, and fast delivery time and high cost performance.
- 3 Reducer has a complete range, which can meet the needs of most reducer in the market.

减速机性能资料 Gear box performance information

型号 Model	单位 Unit	PLFK060	PLFK090	PLFK120	减速比 Ratio	Stage
额定输出扭矩 Rated output torque	N·m	16.5	60	148	3	1
		27	86	222	4	
		27	94.5	235	5	
		19.5	64	158	7	2
		8.5	39.5	93	10	
			96	250	12	
			96	250	15	
		30	96	250	16	
		30	96	250	20	
		33	105.5	264	25	
		30	96	250	28	
		33	105.5	264	35	
		30	96	250	40	
		33	105.5	264	50	
		21.5	71.5	177	70	3
		37.5	120	310	64	
		37.5	120	310	80	
		37.5	120	310	100	
		41.0	132.5	329	125	
		37.5	120	310	140	
		41.0	132.5	329	175	
37.5	120	310	200			
41.0	132.5	329	250			
37.5	120	310	280			
41.0	132.5	329	350			
故障停滞扭矩 Emergency stop torque	N·m	2倍额定输出扭矩 2 times Rated output torque				
额定输入转速 Nominal input speed	rmp	3000	3000	2000		
最大输入转速 Maximum input speed	rmp	6000	6000	3500		
最大径向力 Maximum radial force	N	170	1020	2230		
最大轴向力 Maximum axial force	N	120	850	1550		
效率 Efficiency	%	Single [97%]		Double [95%]		
平均寿命 Average lifetime	h	20000				
重量 Weight	kg	1.4	4.7	6.9		1
		1.6	5.3	8.9		2
		1.8	5.9	11.2		3

减速机性能资料 Gear box performance information

型号 Model	单位 Unit	PLFK060	PLFK090	PLFK120	减速比 Ratio	Stage
转动惯量 Moment of inertia	kgcm ²	0.107	0.4	1.65	3	1
		0.094	0.309	1.22	4	
		0.092	0.291	1.15	5	
		0.091	0.285	1.13	7	2
		0.091	0.283	1.11	10	
			0.4	1.65	12	
			0.309	1.65	15	
		0.094	0.291	1.22	16	
		0.092	0.291	1.15	20	
		0.092	0.291	1.15	25	
		0.091	0.285	1.13	28	
		0.091	0.285	1.13	35	
		0.091	0.2835	1.11	40	
		0.091	0.283	1.11	50	
		0.091	0.283	1.11	70	3
		0.092	0.291	1.15	64	
		0.092	0.291	1.15	80	
		0.092	0.291	1.15	100	
		0.092	0.291	1.15	125	
		0.091	0.291	1.13	140	
		0.091	0.291	1.13	175	
0.091	0.283	1.11	200			
0.091	0.283	1.11	250			
0.091	0.283	1.11	280			
0.091	0.283	1.11	350			
噪音 Noise	dB	60	65	68		
润滑 Lubricating		合成油脂润滑 Synthetic grease lubrication				
防护等级 levels of protection		IP65				

外形尺寸图表

Outline dimensional

PLFK-060-L1

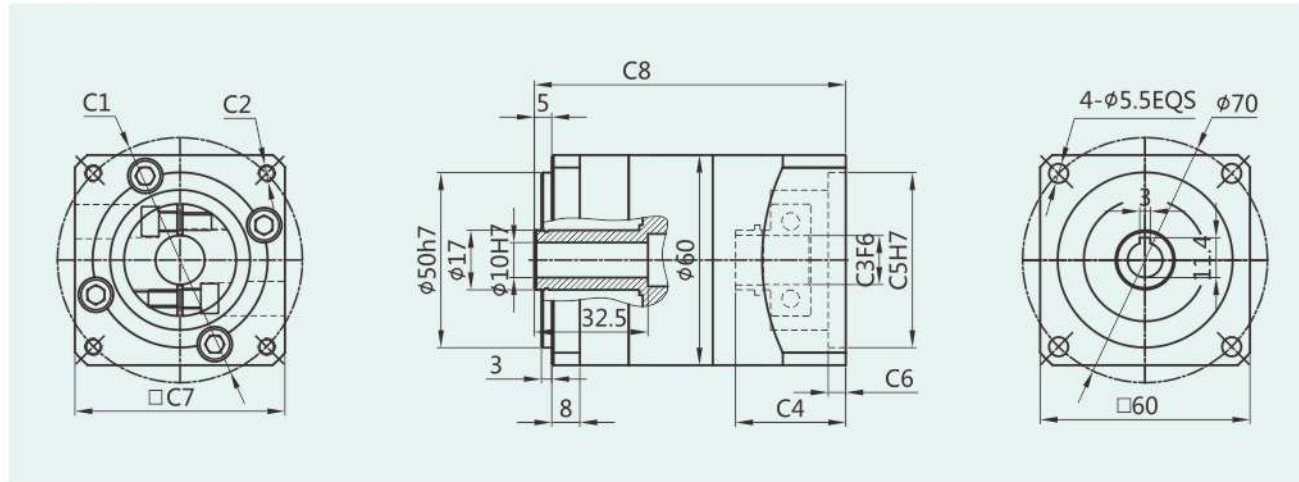

适配电机输入接口尺寸(左端为输入尺寸)
Adapter motor input interface size (The left end is the input size)

尺寸 Size	C1	C2	C3	C4	C5	C6	C7	C8
PLFK-060-L1	□47.14	4-M4	Φ8	31.5	Φ38.1	5.0	60	89
	Φ46	4-M4	Φ8	31.5	Φ30	5.0	60	89
	Φ45	4-M3	Φ8	31.5	Φ30	5.0	60	89
	Φ70	4-M4/4-M5	Φ14	31.5	Φ50	5.0	60	89

PLFK-060-L2

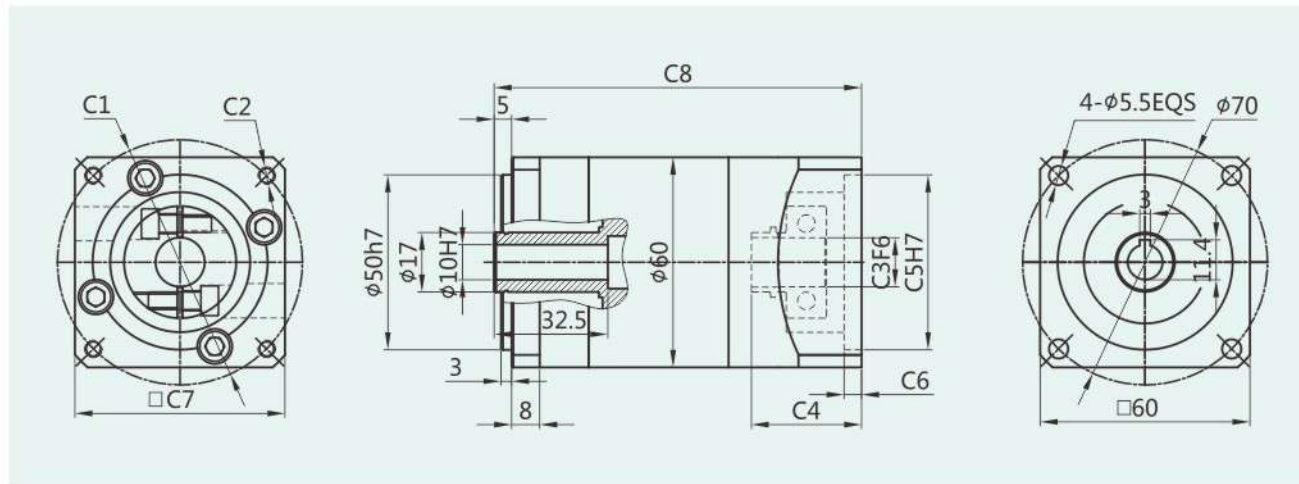

适配电机输入接口尺寸(左端为输入尺寸)
Adapter motor input interface size (The left end is the input size)

尺寸 Size	C1	C2	C3	C4	C5	C6	C7	C8
PLFK-060-L2	□47.14	4-M4	Φ8	31.5	Φ38.1	5.0	60	105
	Φ46	4-M4	Φ8	31.5	Φ30	5.0	60	105
	Φ45	4-M3	Φ8	31.5	Φ30	5.0	60	105
	Φ70	4-M4/4-M5	Φ14	31.5	Φ50	5.0	60	105

外形尺寸图表

Outline dimensional

PLFK-060-L3

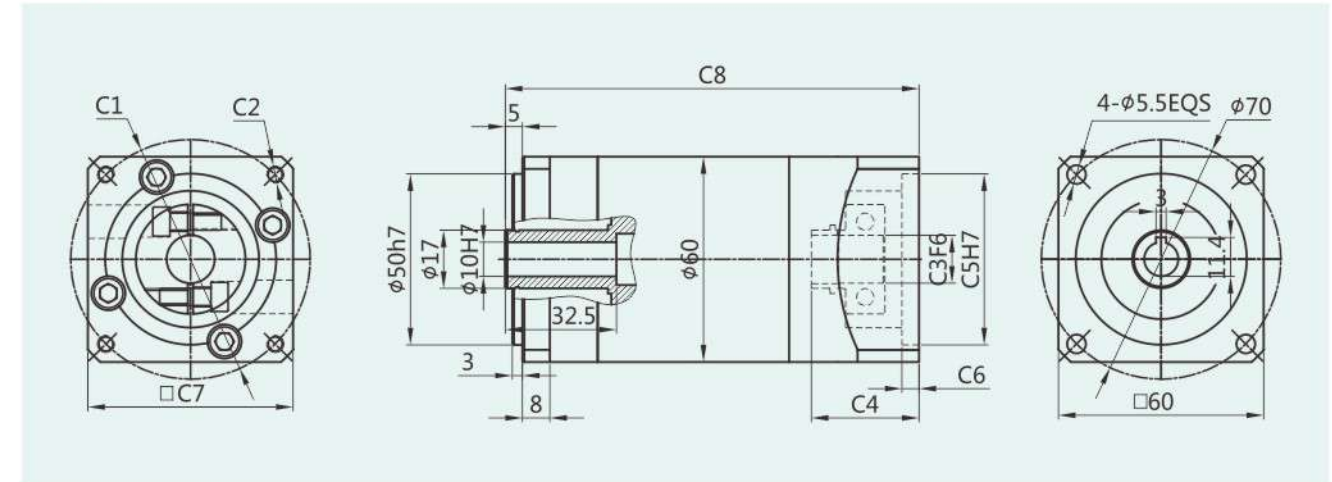

适配电机输入接口尺寸(左端为输入尺寸)
Adapter motor input interface size (The left end is the input size)

尺寸 Size	C1	C2	C3	C4	C5	C6	C7	C8
PLFK-060-L3	□47.14	4-M4	Φ8	31.5	Φ38.1	5.0	60	121
	Φ46	4-M4	Φ8	31.5	Φ30	5.0	60	121
	Φ45	4-M3	Φ8	31.5	Φ30	5.0	60	121
	Φ70	4-M4/4-M5	Φ14	31.5	Φ50	5.0	60	121

PLFK-090-L1

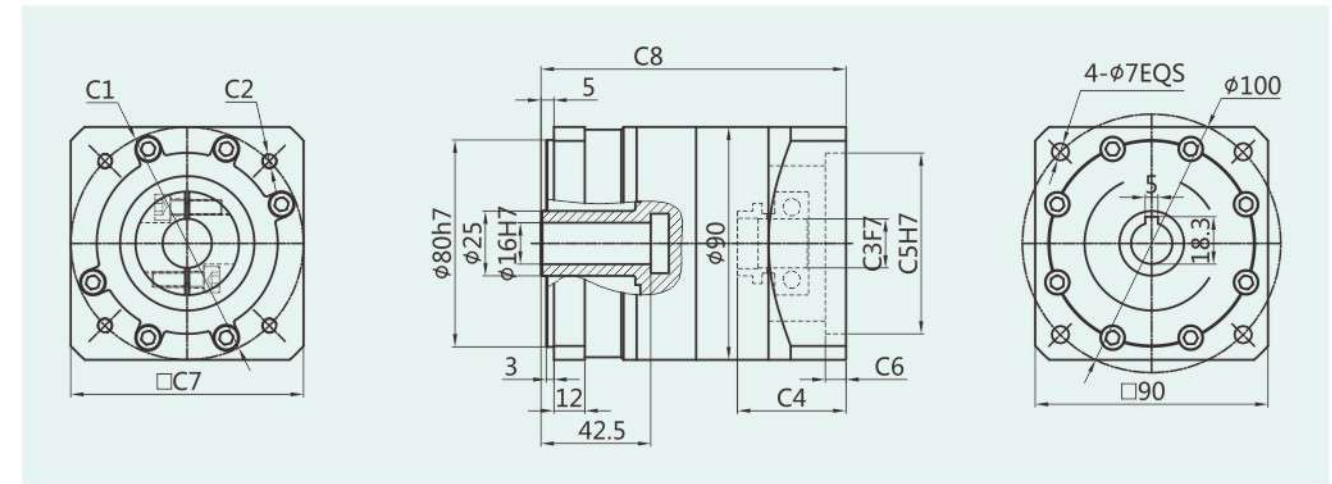

适配电机输入接口尺寸(左端为输入尺寸)
Adapter motor input interface size (The left end is the input size)

尺寸 Size	C1	C2	C3	C4	C5	C6	C7	C8
PLFK-090-L1	Φ70	4-M4/4-M5	Φ14	42	Φ50	8.0	80	118
	□69.6	4-M6	Φ14	42	Φ73	8.0	80	118
	Φ90	4-M5/4-M6	Φ19	42	Φ70	8.0	80	118

外形尺寸图表

Outline dimensional

PLFK-090-L2

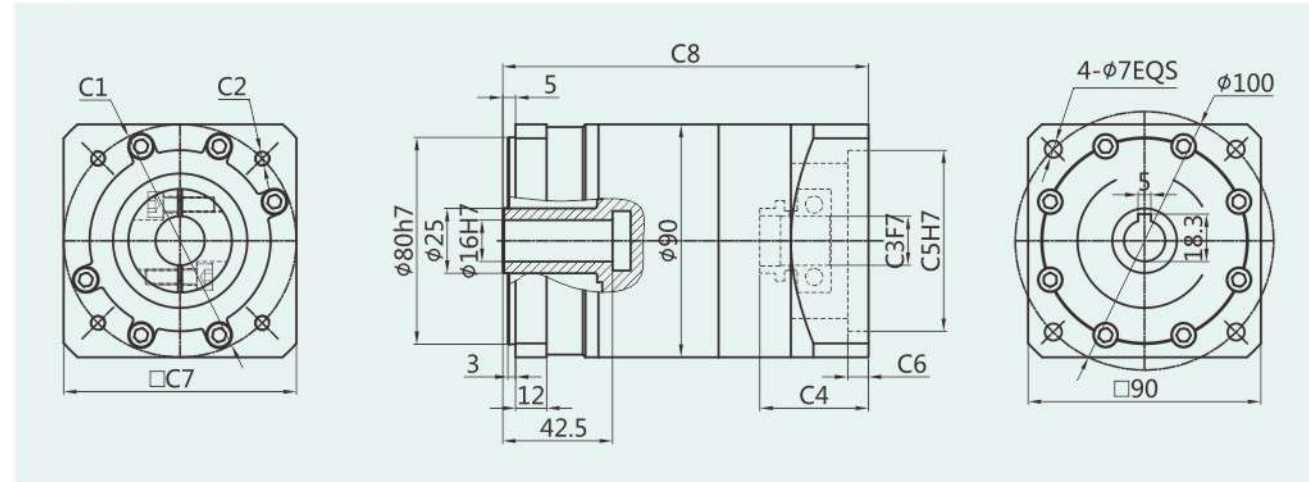

适配电机输入接口尺寸(左端为输入尺寸)
Adapter motor input interface size (The left end is the input size)

尺寸 Size	C1	C2	C3	C4	C5	C6	C7	C8
PLFK-090-L2	Φ70	4-M4/4-M5	Φ14	42	Φ50	8.0	80	141.5
	□69.6	4-M6	Φ14	42	Φ73	8.0	80	141.5
	Φ90	4-M5/4-M6	Φ19	42	Φ70	8.0	80	141.5

PLFK-090-L3

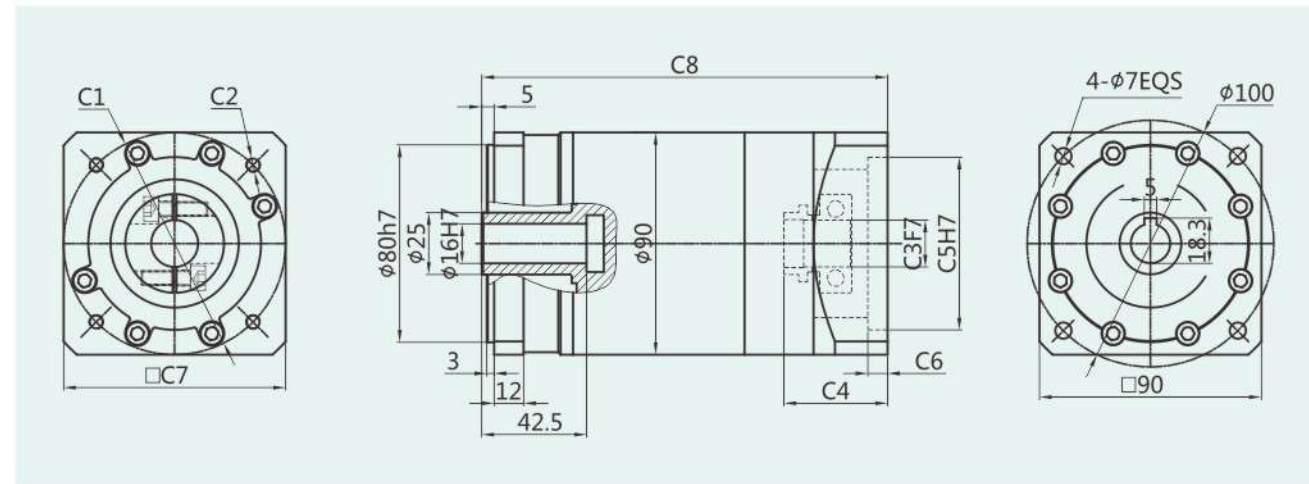

适配电机输入接口尺寸(左端为输入尺寸)
Adapter motor input interface size (The left end is the input size)

尺寸 Size	C1	C2	C3	C4	C5	C6	C7	C8
PLFK-090-L3	Φ70	4-M4/4-M5	Φ14	42	Φ50	8.0	90	164.5
	□69.6	4-M6	Φ14	42	Φ73	8.0	90	164.5
	Φ90	4-M5/4-M6	Φ19	42	Φ70	8.0	90	164.5

外形尺寸图表

Outline dimensional

PLFK-120-L1

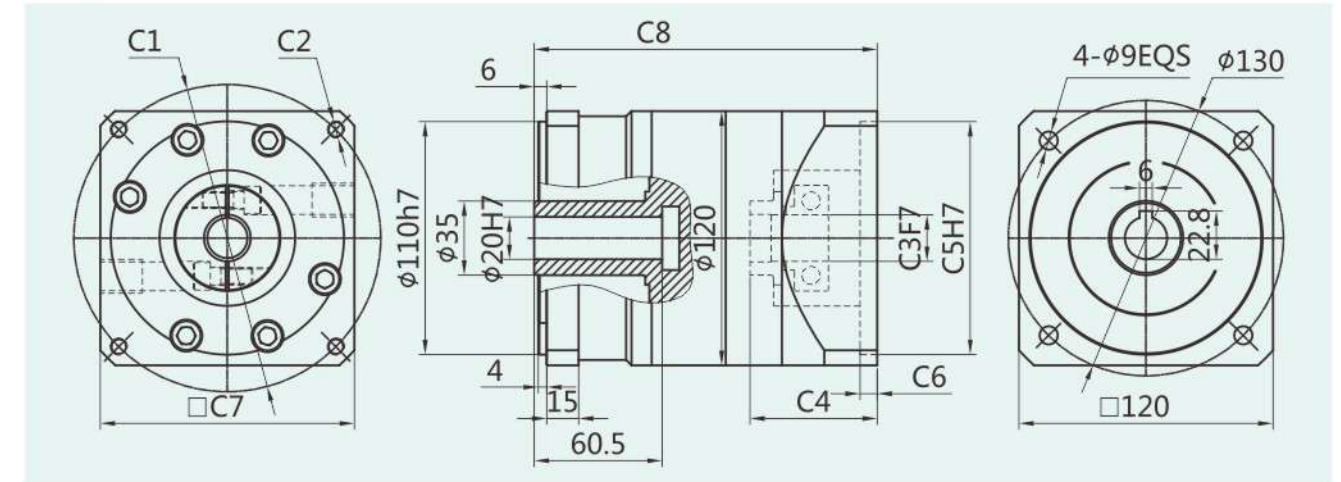

适配电机输入接口尺寸(左端为输入尺寸)
Adapter motor input interface size (The left end is the input size)

尺寸 Size	C1	C2	C3	C4	C5	C6	C7	C8
PLFK-120-L1	Φ90	4-M5/4-M6	Φ19	47	Φ70	8	90	151
	Φ115	4-M8	Φ19/Φ22	60	Φ95	8	130	162
	Φ130	4-M8	Φ19/Φ22	60	Φ95	8	130	162
	Φ145	4-M8	Φ19/Φ22/Φ24	60	Φ110	8	180	162

PLFK-120-L2

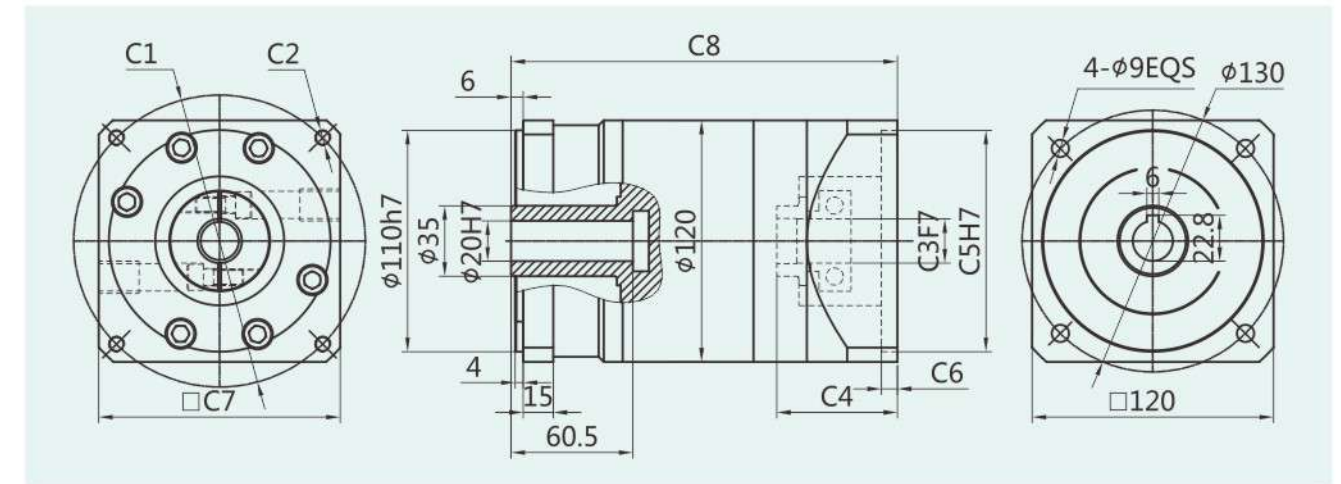

适配电机输入接口尺寸(左端为输入尺寸)
Adapter motor input interface size (The left end is the input size)

尺寸 Size	C1	C2	C3	C4	C5	C6	C7	C8
PLFK-120-L2	Φ90	4-M5/4-M6	Φ19	47	Φ70	8	90	181
	Φ115	4-M8	Φ19/Φ22	60	Φ95	8	130	192
	Φ130	4-M8	Φ19/Φ22	60	Φ95	8	130	192
	Φ145	4-M8	Φ19/Φ22/Φ24	60	Φ110	8	180	192

外形尺寸图表

Outline dimensional

PLFK-120-L3

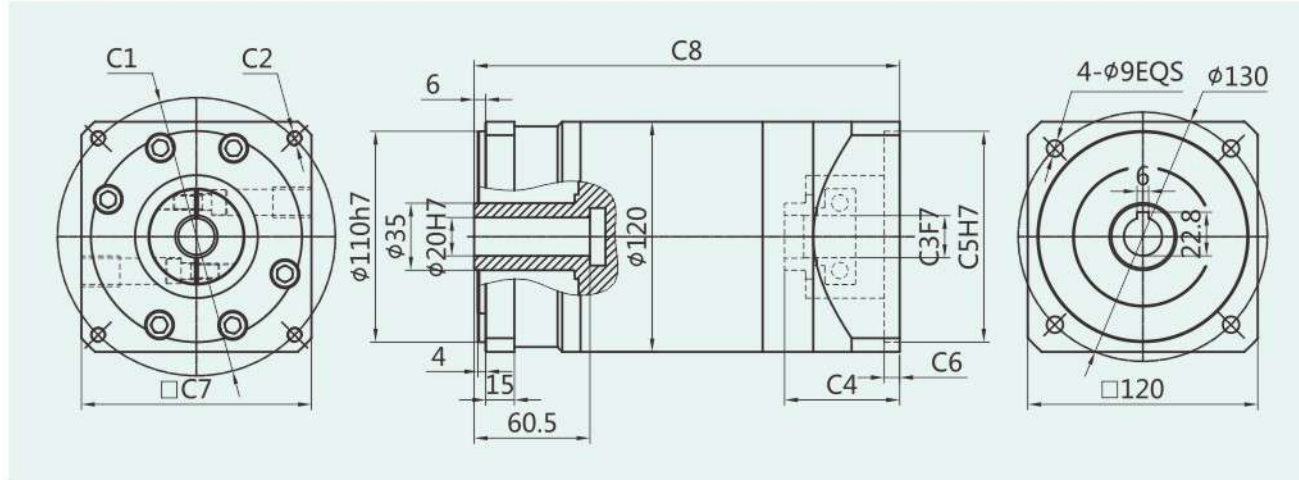

适配电机输入接口尺寸(左端为输入尺寸)

Adapter motor input interface size (The left end is the input size)

尺寸 Size	C1	C2	C3	C4	C5	C6	C7	C8
PLFK-120-L3	Φ90	4-M5/4-M6	Φ19	47	Φ70	8	90	211
	Φ115	4-M8	Φ19/Φ22	60	Φ95	8	130	222
	Φ130	4-M8	Φ19/Φ22	60	Φ95	8	130	222
	Φ145	4-M8	Φ19/Φ22/Φ24	60	Φ110	8	180	222

减速机性能资料

Gear box performance information

型号 Model	单位 Unit	PLFK142	PLFK160	减速比 Ratio	Stage	
额定输出扭矩 Rated output torque	N·m	310	310	3	1	
		605	605	4		
		420	420	5		2
		270	270	8		
		680	680	12		
		680	680	16		
		680	680	20		
		460	460	25		
		680	680	32		
		460	460	40		
		310	310	64	3	
		900	900	64		
		900	900	80		
		900	900	100		
		580	580	125		
		580	580	160		
		580	580	200		
		900	900	256		
		580	580	320		
		400	400	512		
故障停滞扭矩 Emergency stop torque	N·m	2倍额定输出扭矩 2 times Rated output torque				
额定输入转速 Nominal input speed	rmp	2000	2000			
最大输入转速 Maximum input speed	rmp	3500	3500			
最大径向力 Maximum radial force	N	3200	3200			
最大轴向力 Maximum axial force	N	3000	3000			
效率 Efficiency	%	Single [97%]		Double [95%]		
平均寿命 Average lifetime	h	20000				
重量 Weight	kg	17	19		1	
		23	25		2	
		29	31		3	

减速机性能资料 Gear box performance information

型号 Model	单位 Unit	PLXK142	PLFK160	减速比 Ratio	Stage
转动惯量 Moment of inertia	kgcm ²	4.31	4.31	3	1
		5.15	5.15	4	
		4.93	4.93	5	
		4.84	4.84	8	2
		6.31	6.31	12	
		5.15	5.15	16	
		4.93	4.93	20	
		4.93	4.93	25	
		4.84	4.84	32	
		4.84	4.84	40	3
		4.84	4.84	64	
		4.93	4.93	64	
		4.93	4.93	80	
		4.93	4.93	100	
		4.84	4.84	125	
		4.84	4.84	160	3
		4.84	4.84	200	
		4.84	4.84	256	
4.84	4.84	320			
4.84	4.84	512			
噪音 Noise	dB	70	70		
润滑 Lubricating		合成油脂润滑 Synthetic grease lubrication			
防护等级 levels of protection		IP65			

外形尺寸图表 Outline dimensional

PLXK-142-L1

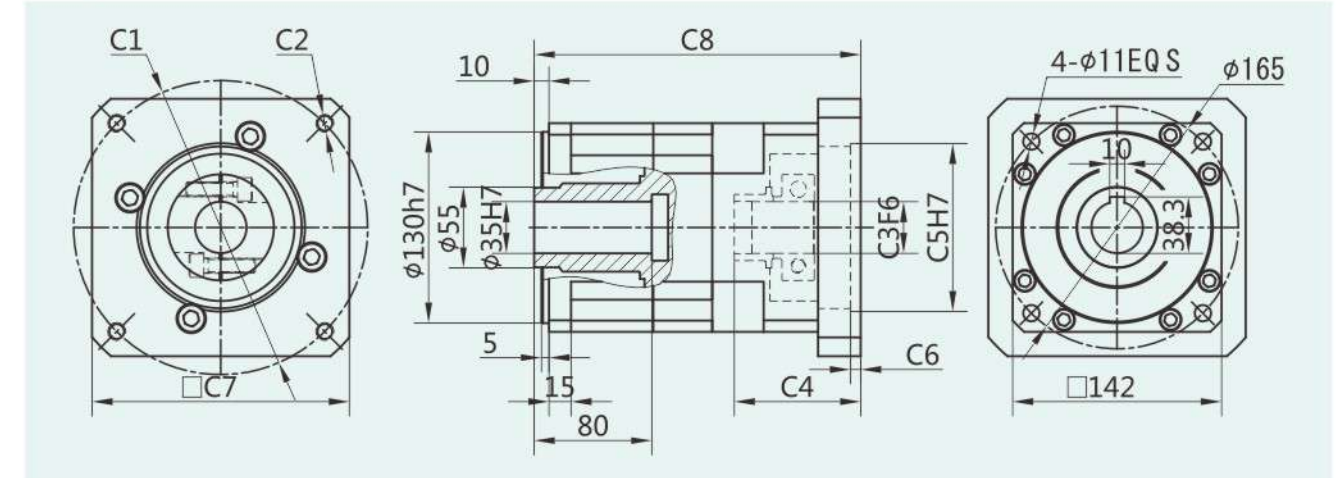

适配电机输入接口尺寸(左端为输入尺寸)
Adapter motor input interface size (The left end is the input size)

尺寸 Size	C1	C2	C3	C4	C5	C6	C7	C8
PLXK-142-L1	Φ130	4-M8	Φ22	62	Φ95	7	142	198
	Φ145	4-M8	Φ22/Φ24	62	Φ110	7	142	198
	Φ165	4-M10	Φ32	62	Φ130	7	142	198
	Φ200	4-M12	Φ35	86	Φ114.3	7	175	222
	Φ200	4-M12	Φ35	117	Φ114.3	7	175	253
	Φ215	4-M12	Φ38/Φ42	86	Φ180	7	190	222

PLXK-142-L2

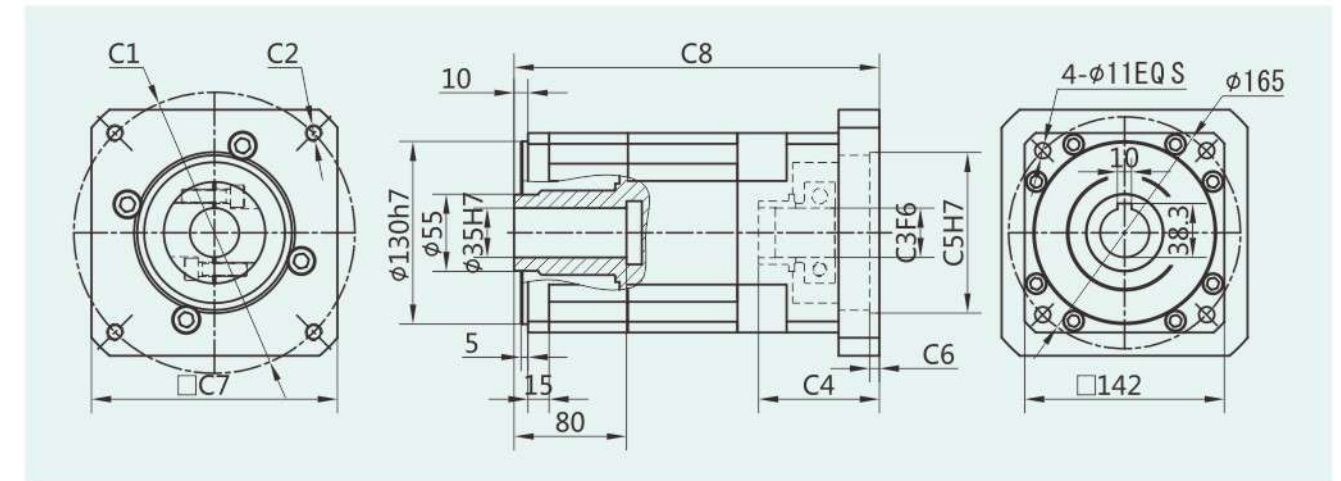

适配电机输入接口尺寸(左端为输入尺寸)
Adapter motor input interface size (The left end is the input size)

尺寸 Size	C1	C2	C3	C4	C5	C6	C7	C8
PLXK-142-L2	Φ130	4-M8	Φ22	62	Φ95	7	142	236
	Φ145	4-M8	Φ22/Φ24	62	Φ110	7	142	236
	Φ165	4-M10	Φ32	62	Φ130	7	142	236
	Φ200	4-M12	Φ35	86	Φ114.3	7	175	260
	Φ200	4-M12	Φ35	117	Φ114.3	7	175	291
	Φ215	4-M12	Φ38/Φ42	86	Φ180	7	190	260

PLFK Series

外形尺寸图表

Outline dimensional

PLXK-142-L3

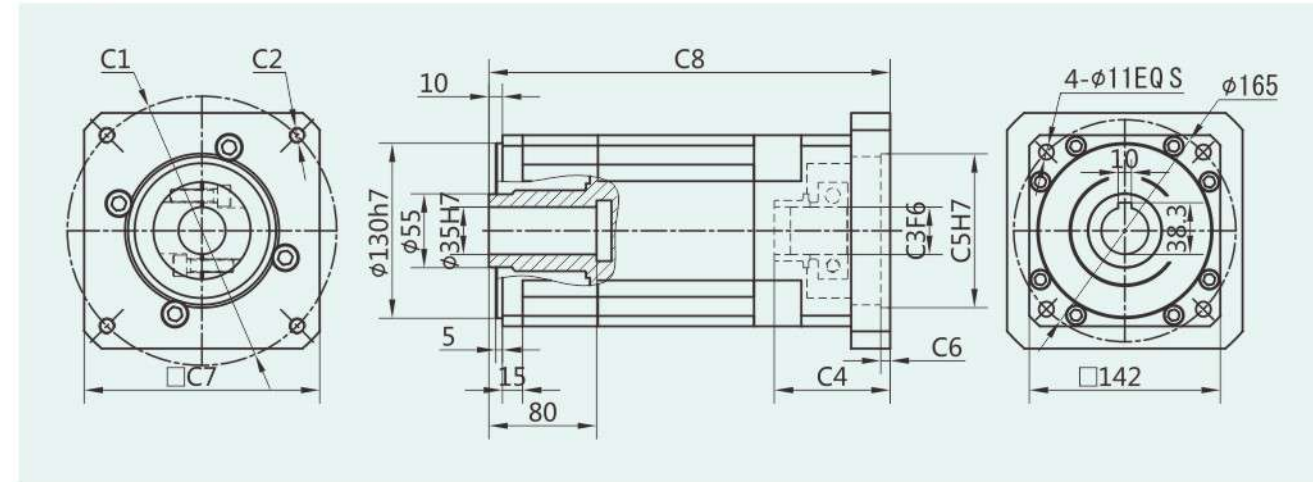

适配电机输入接口尺寸(左端为输入尺寸)

Adapter motor input interface size (The left end is the input size)

尺寸 Size	C1	C2	C3	C4	C5	C6	C7	C8
ZPLX-142-L3	φ130	4-M8	φ22	62	φ95	7	142	274
	φ145	4-M8	φ22/φ24	62	φ110	7	142	274
	φ165	4-M10	φ32	62	φ130	7	142	274
	φ200	4-M12	φ35	86	φ114.3	7	175	298
	φ200	4-M12	φ35	117	φ114.3	7	175	329
	φ215	4-M12	φ38/φ42	86	φ180	7	190	298

PLFK-160-L1

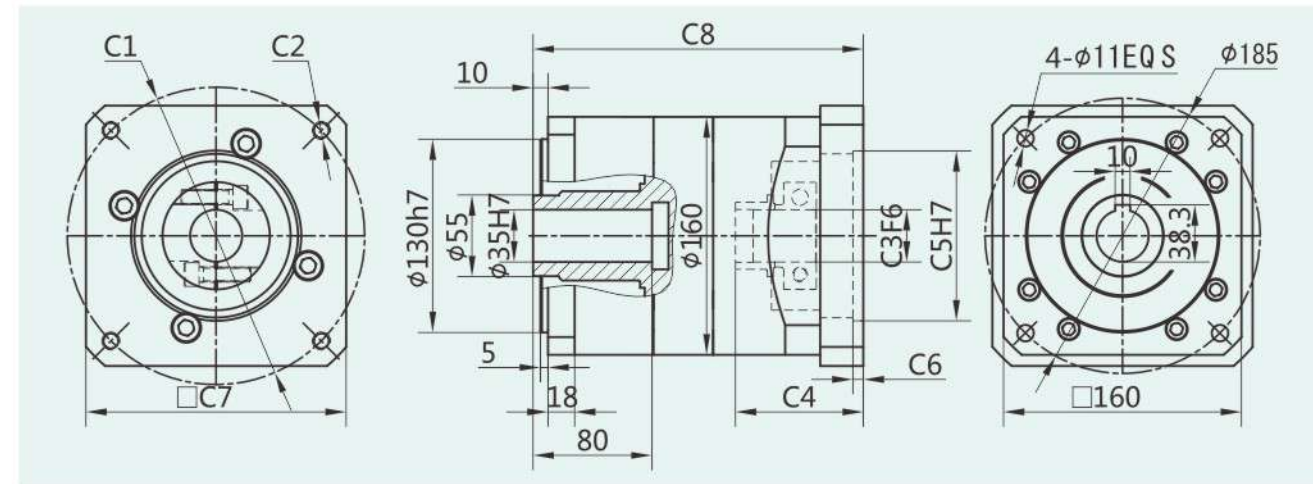

适配电机输入接口尺寸(左端为输入尺寸)

Adapter motor input interface size (The left end is the input size)

尺寸 Size	C1	C2	C3	C4	C5	C6	C7	C8
PLFK-160-L1	φ130	4-M8	φ22	62	φ95	7	142	198
	φ145	4-M8	φ22/φ24	62	φ110	7	142	198
	φ165	4-M10	φ32	62	φ130	7	142	198
	φ200	4-M12	φ35	86	φ114.3	7	175	222
	φ200	4-M12	φ35	117	φ114.3	7	175	253
	φ215	4-M12	φ38/φ42	86	φ180	7	190	222

外形尺寸图表

Outline dimensional

PLFK-160-L2

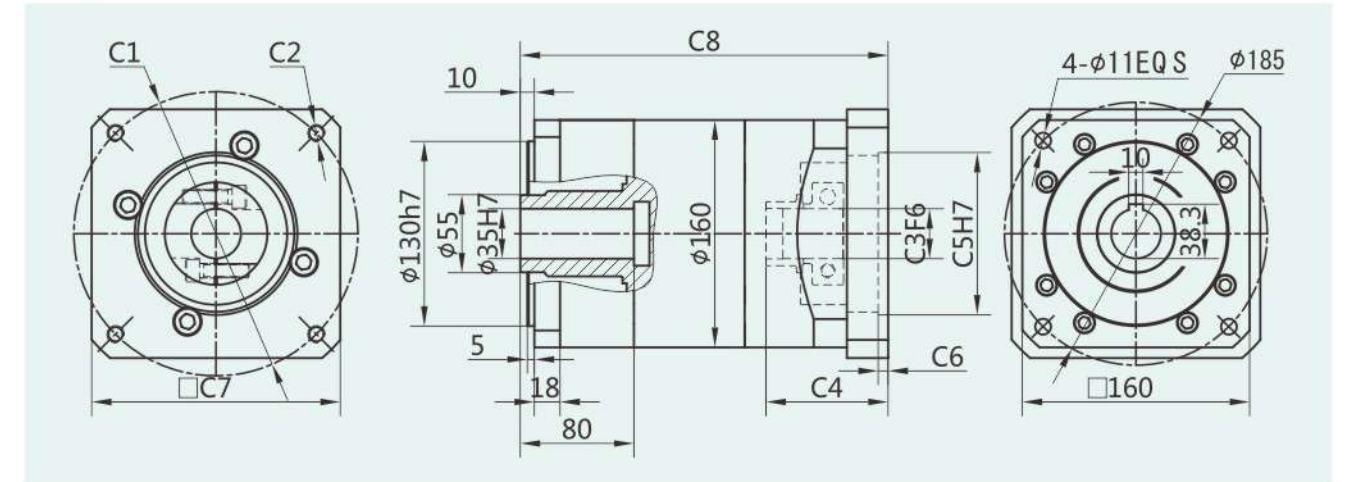

适配电机输入接口尺寸(左端为输入尺寸)

Adapter motor input interface size (The left end is the input size)

尺寸 Size	C1	C2	C3	C4	C5	C6	C7	C8
PLFK-160-L2	φ130	4-M8	φ22	62	φ95	7	142	236
	φ145	4-M8	φ22/φ24	62	φ110	7	142	236
	φ165	4-M10	φ32	62	φ130	7	142	236
	φ200	4-M12	φ35	86	φ114.3	7	175	260
	φ200	4-M12	φ35	117	φ114.3	7	175	291
	φ215	4-M12	φ38/φ42	86	φ180	7	190	260

PLFK-160-L3

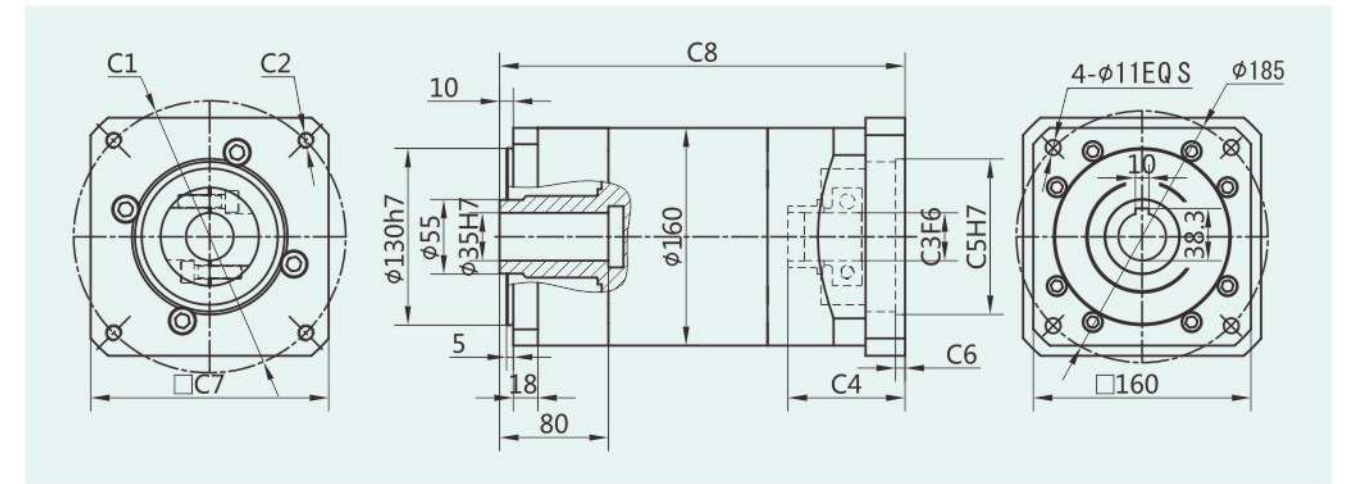

适配电机输入接口尺寸(左端为输入尺寸)

Adapter motor input interface size (The left end is the input size)

尺寸 Size	C1	C2	C3	C4	C5	C6	C7	C8
PLFK-160-L3	φ130	4-M8	φ22	62	φ95	7	142	274
	φ145	4-M8	φ22/φ24	62	φ110	7	142	274
	φ165	4-M10	φ32	62	φ130	7	142	274
	φ200	4-M12	φ35	86	φ114.3	7	175	298
	φ200	4-M12	φ35	117	φ114.3	7	175	329
	φ215	4-M12	φ38/φ42	86	φ180	7	190	298

- ✓ PLEK060
- ✓ PLEK090
- ✓ PLEK120



PLEK

Series

PLEK系列减速机核心特性

The Core Characteristics of PLEK Series Reducer

- 1 采用直齿齿轮传动，经渗碳淬火处理，齿向齿廓修形处理，确保运行平稳，噪音小；
- 2 结构简单，可大批量生产，且交货期快性价比高；
- 3 减速机种类齐全，可以满足市场上绝大多数减速机的配合。

- 1 Adopt straight tooth gear transmission, through carburizing and quenching treatment, tooth profile modification treatment, ensure smooth operation, low noise.
- 2 Simple structure, mass production, and fast delivery time and high cost performance.
- 3 Reducer has a complete range, which can meet the needs of most reducer in the market.

减速机性能资料

Gear box performance information

型号 Model	单位 Unit	PLEK060	PLEK090	PLEK120	减速比 Ratio	Stage
额定输出扭矩 Rated output torque	N·m	16.5	60	148	3	1
		27	86	222	4	
		27	94.5	235	5	
		19.5	64	158	7	
		8.5	39.5	93	10	
			96	250	12	2
			96	250	15	
		30	96	250	16	
		30	96	250	20	
		33	105.5	264	25	
		30	96	250	28	
		33	105.5	264	35	
		30	96	250	40	3
		33	105.5	264	50	
		21.5	71.5	177	70	
		37.5	120	310	64	
		37.5	120	310	80	
		37.5	120	310	100	
		41.0	132.5	329	125	
		37.5	120	310	140	
41.0	132.5	329	175			
37.5	120	310	200			
41.0	132.5	329	250			
37.5	120	310	280			
41.0	132.5	329	350			
故障停滞扭矩 Emergency stop torque	N·m	2倍额定输出扭矩 2 times Rated output torque				
额定输入转速 Norminal input speed	rmp	3000	3000	2000		
最大输入转速 Maximum input speed	rmp	6000	6000	3500		
最大径向力 Maximum radial force	N	170	1020	2230		
最大轴向力 Maximum axial force	N	120	850	1550		
效率 Efficiency	%	Single [97%]		Double [95%]		
平均寿命 Average lifetime	h	20000				
重量 Weight	kg	1.4	4.7	6.9		1
		1.6	5.3	8.9		2
		1.8	5.9	11.2		3

减速机性能资料 Gear box performance information

型号 Model	单位 Unit	PLEK060	PLEK090	PLEK120	减速比 Ratio	Stage		
转动惯量 Moment of inertia	kgcm ²	0.107	0.4	1.65	3	1		
		0.094	0.309	1.22	4			
		0.092	0.291	1.15	5			
		0.091	0.285	1.13	7			
		0.091	0.283	1.11	10			
				0.4	1.65	12	2	
				0.309	1.65	15		
		0.094	0.291	1.22	16			
		0.092	0.291	1.15	20			
		0.092	0.291	1.15	25			
		0.091	0.285	1.13	28			
		0.091	0.285	1.13	35			
		0.091	0.2835	1.11	40			
		0.091	0.283	1.11	50			
		0.091	0.283	1.11	70			
				0.092	0.291	1.15	64	3
				0.092	0.291	1.15	80	
				0.092	0.291	1.15	100	
				0.092	0.291	1.15	125	
				0.091	0.291	1.13	140	
		0.091	0.291	1.13	175			
		0.091	0.283	1.11	200			
		0.091	0.283	1.11	250			
噪音 Noise	dB	60	65	68				
润滑 Lubricating		合成油脂润滑 Synthetic grease lubrication						
防护等级 levels of protection		IP65						

外形尺寸图表 Outline dimensional

PLEK-060-L1

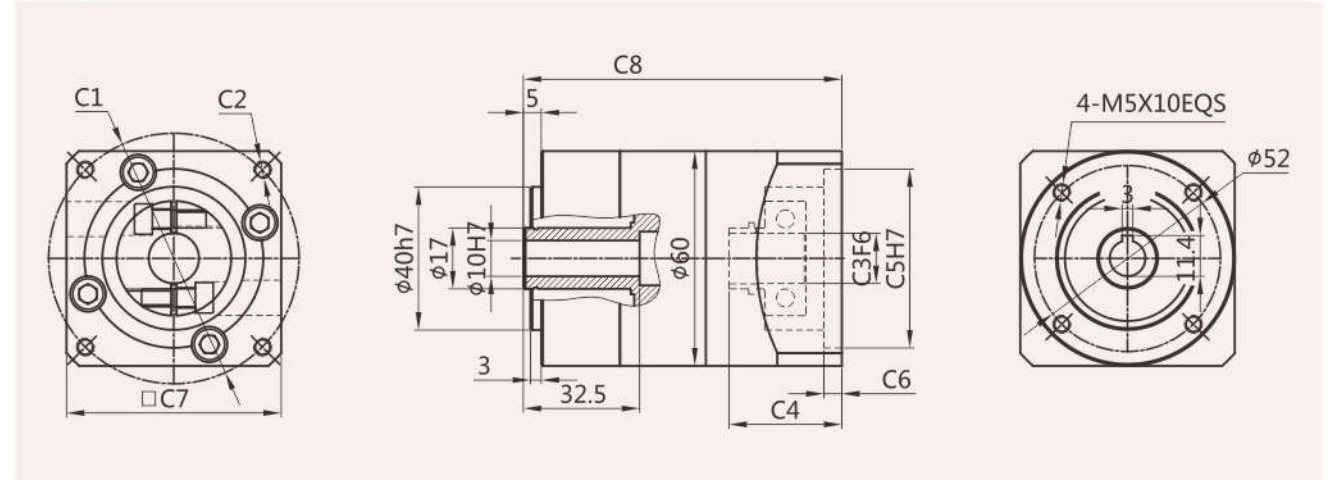

适配电机输入接口尺寸(左端为输入尺寸)
Adapter motor input interface size (The left end is the input size)

尺寸 Size	C1	C2	C3	C4	C5	C6	C7	C8
PLEK-060-L1	□47.14	4-M4	Φ8	31.5	Φ38.1	5.0	60	89
	Φ46	4-M4	Φ8	31.5	Φ30	5.0	60	89
	Φ45	4-M3	Φ8	31.5	Φ30	5.0	60	89
	Φ70	4-M4/4-M5	Φ14	31.5	Φ50	5.0	60	89

PLEK-060-L2

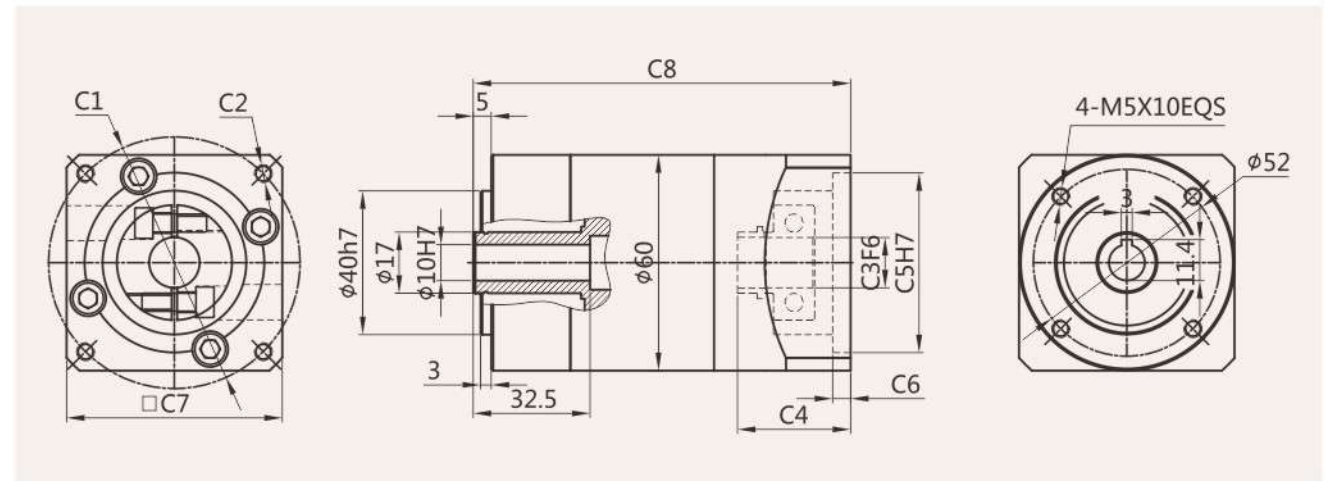

适配电机输入接口尺寸(左端为输入尺寸)
Adapter motor input interface size (The left end is the input size)

尺寸 Size	C1	C2	C3	C4	C5	C6	C7	C8
PLEK-060-L2	□47.14	4-M4	Φ8	31.5	Φ38.1	5.0	60	105
	Φ46	4-M4	Φ8	31.5	Φ30	5.0	60	105
	Φ45	4-M3	Φ8	31.5	Φ30	5.0	60	105
	Φ70	4-M4/4-M5	Φ14	31.5	Φ50	5.0	60	105

外形尺寸图表

Outline dimensional

PLEK-060-L3

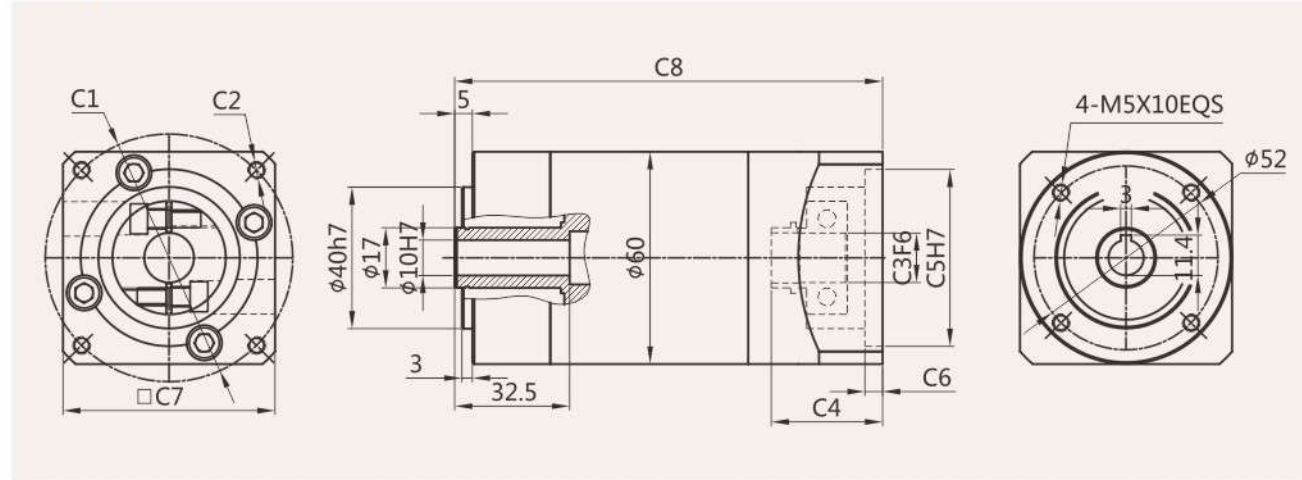

适配电机输入接口尺寸(左端为输入尺寸)

Adapter motor input interface size (The left end is the input size)

尺寸 Size	C1	C2	C3	C4	C5	C6	C7	C8
PLEK-060-L3	$\square 47.14$	4-M4	$\phi 8$	31.5	$\phi 38.1$	5.0	60	121
	$\phi 46$	4-M4	$\phi 8$	31.5	$\phi 30$	5.0	60	121
	$\phi 45$	4-M3	$\phi 8$	31.5	$\phi 30$	5.0	60	121
	$\phi 70$	4-M4/4-M5	$\phi 14$	31.5	$\phi 50$	5.0	60	121

PLEK-090-L1

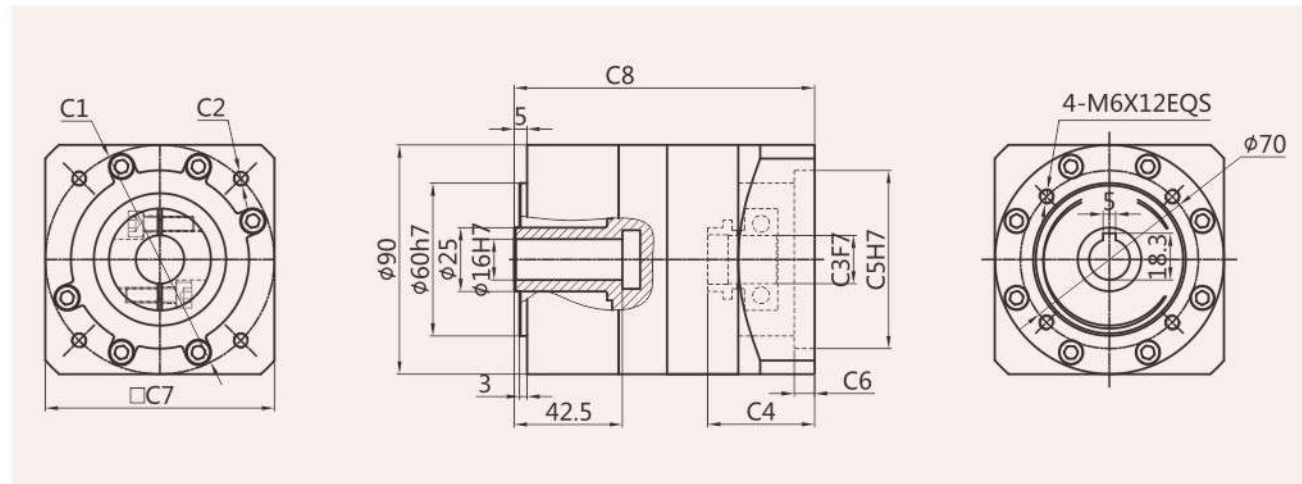

适配电机输入接口尺寸(左端为输入尺寸)

Adapter motor input interface size (The left end is the input size)

尺寸 Size	C1	C2	C3	C4	C5	C6	C7	C8
PLEK-090-L1	$\phi 70$	4-M4/4-M5	$\phi 14$	42	$\phi 50$	8.0	80	118
	$\square 69.6$	4-M6	$\phi 14$	42	$\phi 73$	8.0	80	118
	$\phi 90$	4-M5/4-M6	$\phi 19$	42	$\phi 70$	8.0	80	118

外形尺寸图表

Outline dimensional

PLEK-090-L2

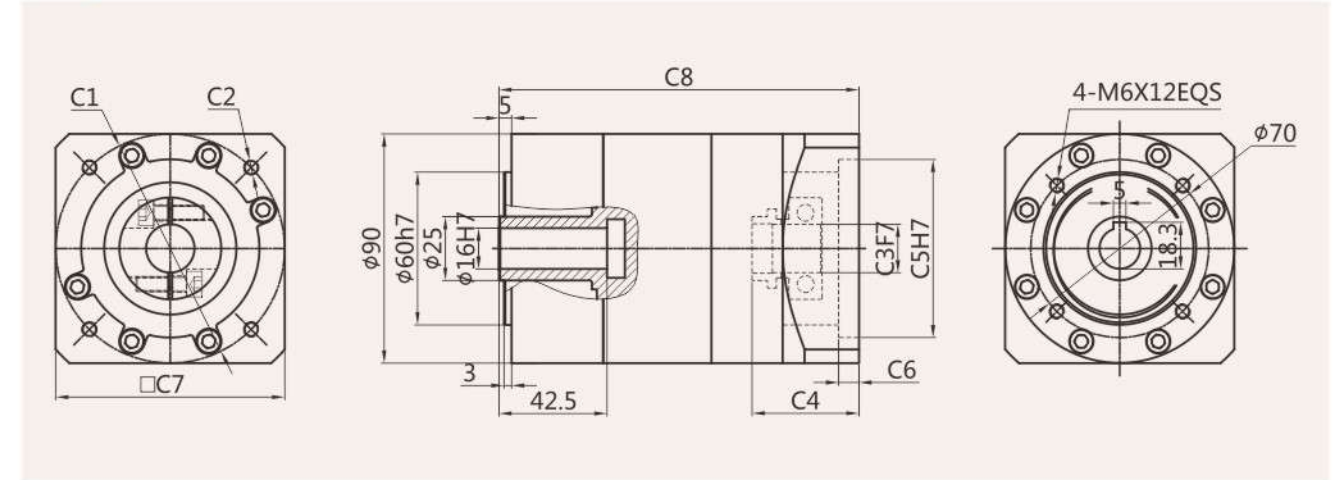

适配电机输入接口尺寸(左端为输入尺寸)

Adapter motor input interface size (The left end is the input size)

尺寸 Size	C1	C2	C3	C4	C5	C6	C7	C8
PLEK-090-L2	$\phi 70$	4-M4/4-M5	$\phi 14$	42	$\phi 50$	8.0	80	141.5
	$\square 69.6$	4-M6	$\phi 14$	42	$\phi 73$	8.0	80	141.5
	$\phi 90$	4-M5/4-M6	$\phi 19$	42	$\phi 70$	8.0	80	141.5

PLEK-090-L3

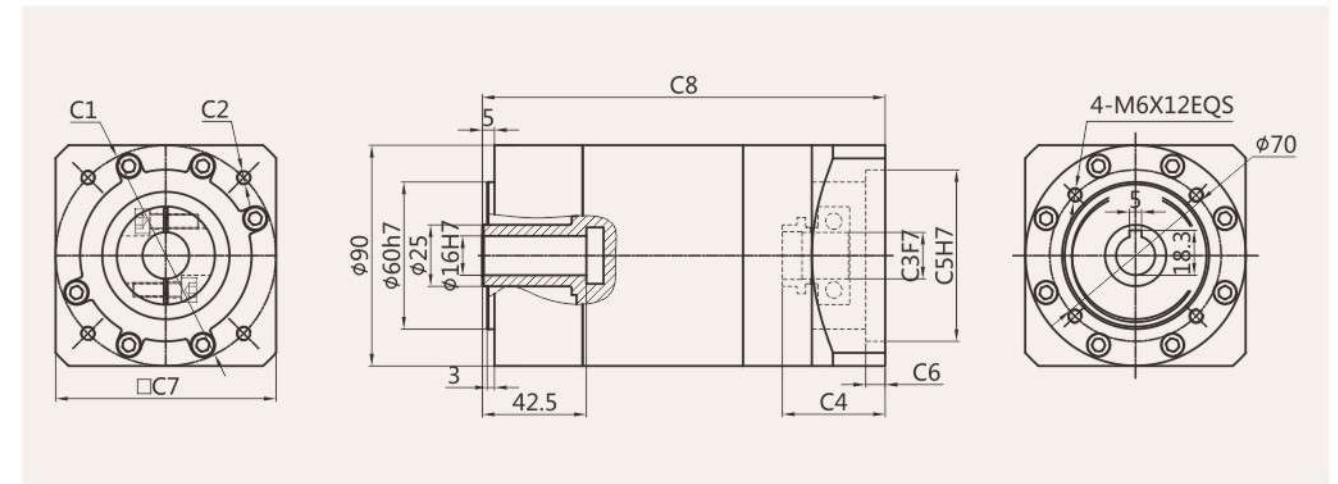

适配电机输入接口尺寸(左端为输入尺寸)

Adapter motor input interface size (The left end is the input size)

尺寸 Size	C1	C2	C3	C4	C5	C6	C7	C8
PLEK-090-L3	$\phi 70$	4-M4/4-M5	$\phi 14$	42	$\phi 50$	8.0	90	164.5
	$\square 69.6$	4-M6	$\phi 14$	42	$\phi 73$	8.0	90	164.5
	$\phi 90$	4-M5/4-M6	$\phi 19$	42	$\phi 70$	8.0	90	164.5

外形尺寸图表

Outline dimensional

PLEK-120-L1

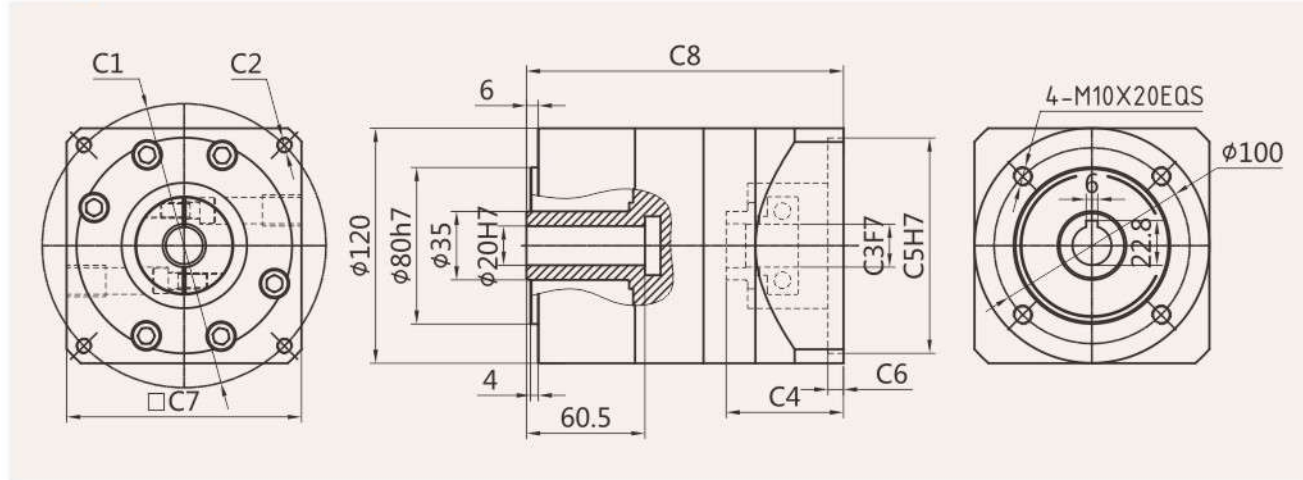

适配电机输入接口尺寸(左端为输入尺寸)

Adapter motor input interface size (The left end is the input size)

尺寸 Size	C1	C2	C3	C4	C5	C6	C7	C8
PLEK-120-L1	Φ90	4-M5/4-M6	Φ19	47	Φ70	8	90	151
	Φ115	4-M8	Φ19/Φ22	60	Φ95	8	130	162
	Φ130	4-M8	Φ19/Φ22	60	Φ95	8	130	162
	Φ145	4-M8	Φ19/Φ22/Φ24	60	Φ110	8	180	162

PLEK-120-L2

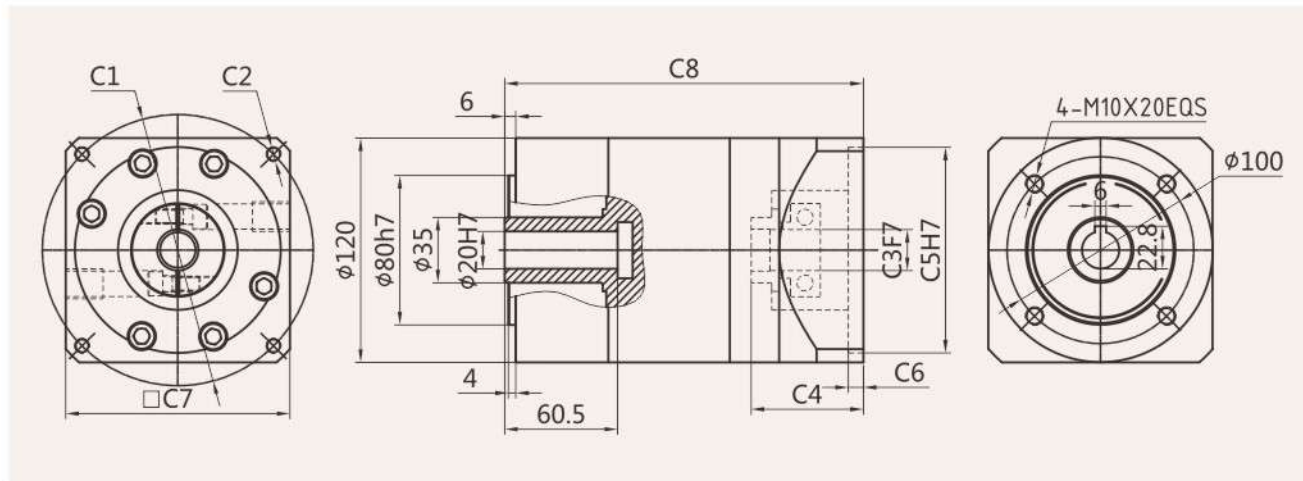

适配电机输入接口尺寸(左端为输入尺寸)

Adapter motor input interface size (The left end is the input size)

尺寸 Size	C1	C2	C3	C4	C5	C6	C7	C8
PLEK-120-L2	Φ90	4-M5/4-M6	Φ19	47	Φ70	8	90	181
	Φ115	4-M8	Φ19/Φ22	60	Φ95	8	130	192
	Φ130	4-M8	Φ19/Φ22	60	Φ95	8	130	192
	Φ145	4-M8	Φ19/Φ22/Φ24	60	Φ110	8	180	192

外形尺寸图表

Outline dimensional

PLEK-120-L3

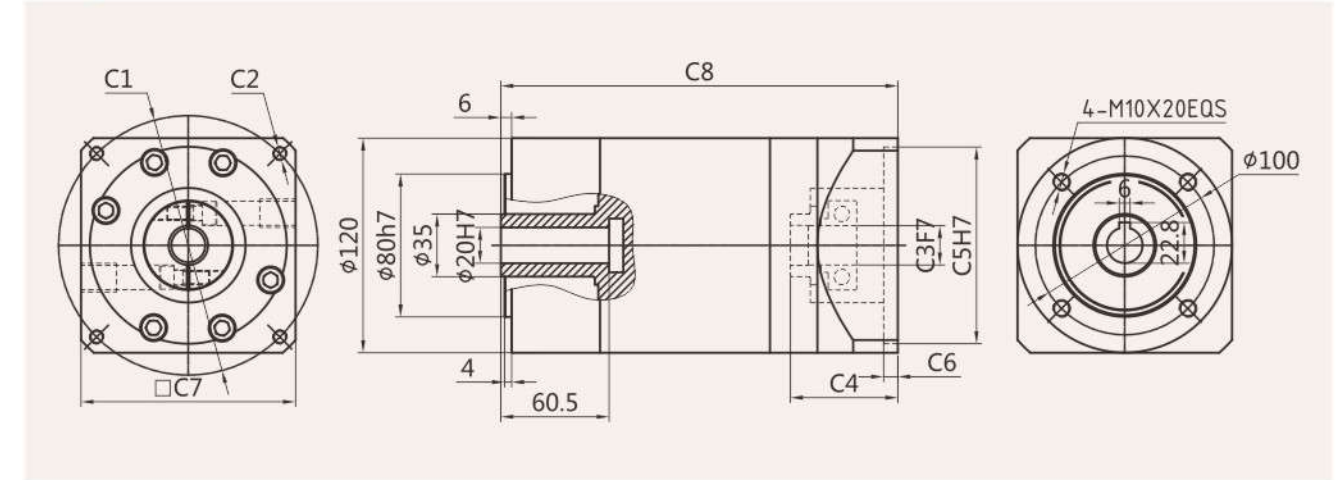

适配电机输入接口尺寸(左端为输入尺寸)

Adapter motor input interface size (The left end is the input size)

尺寸 Size	C1	C2	C3	C4	C5	C6	C7	C8
PLEK-120-L3	Φ90	4-M5/4-M6	Φ19	47	Φ70	8	90	211
	Φ115	4-M8	Φ19/Φ22	60	Φ95	8	130	222
	Φ130	4-M8	Φ19/Φ22	60	Φ95	8	130	222
	Φ145	4-M8	Φ19/Φ22/Φ24	60	Φ110	8	180	222

VLF078

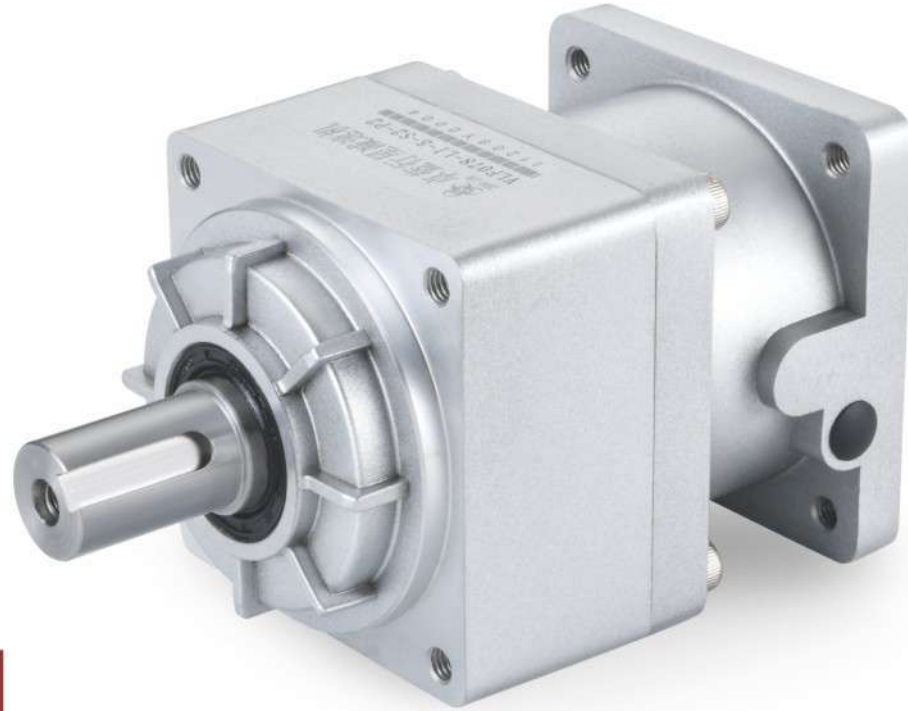

VLF Series

VLF系列减速机核心特性

The Core Characteristics of VLF Series Reducer

- 1 采用直齿齿轮传动，经渗碳淬火处理，齿向齿廓修形处理，确保运行平稳，噪音小；
- 2 结构简单，可大批量生产，且交货期快性价比高；
- 3 减速机种类齐全，可以满足市场上绝大多数减速机的配合。

- 1 Adopt straight tooth gear transmission, through carburizing and quenching treatment, tooth profile modification treatment, ensure smooth operation, low noise.
- 2 Simple structure, mass production, and fast delivery time and high cost performance.
- 3 Reducer has a complete range, which can meet the needs of most reducer in the market.

减速机性能资料

Gear box performance information

型号 Model	单位 Unit	VLF078	减速比 Ratio	Stage
额定输出扭矩 Rated output torque	N·m	92	5	1
		41	9	
故障停滞扭矩 Emergency stop torque	N·m	2倍额定输出扭矩 2 times Rated output torque		1
额定输入转速 Norminal input speed	rmp	3000		
最大输入转速 Maximum input speed	rmp	6000		
最大径向力 Maximum radial force	N	2000		
最大轴向力 Maximum axial force	N	1800		
效率 Efficiency	%	Single [97%]		
平均寿命 Average lifetime	h	2000		
重量 Weight	kg	3.7		1
转动惯量 Moment of inertia	kgcm ²	0.291	5	1
		0.12	9	
噪音 Noise	dB	65		
润滑 Lubricating		合成油脂润滑 Synthetic grease lubrication		
防护等级 levels of protection		IP65		

外形尺寸图表

Outline dimensional

VLF078

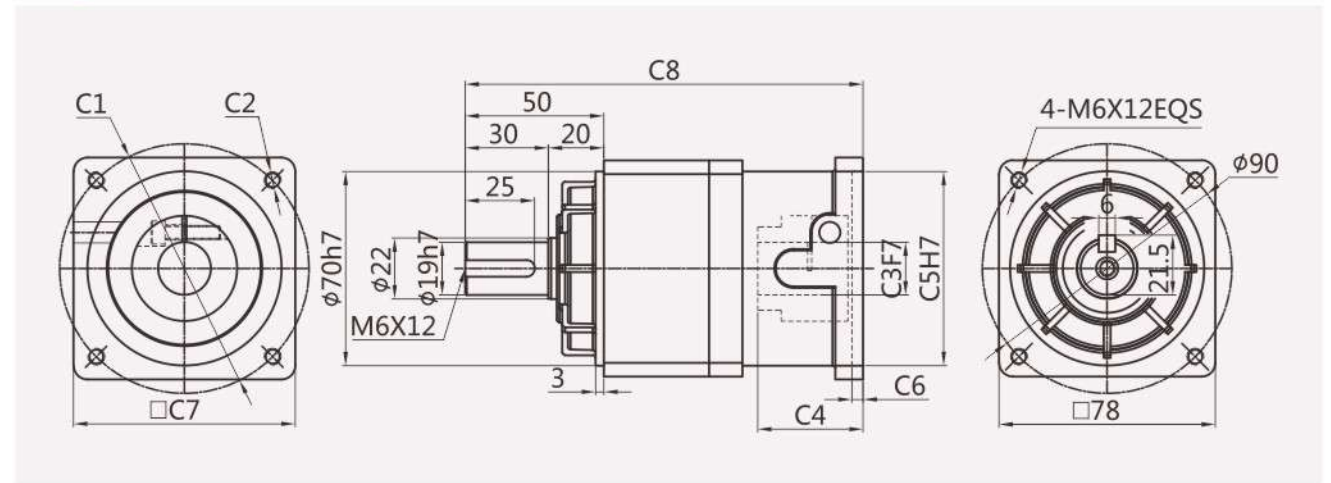

适配电机输入接口尺寸(左端为输入尺寸)

Adapter motor input interface size (The left end is the input size)

尺寸 Size	C1	C2	C3	C4	C5	C6	C7	C8
VLF078	φ70	4-M4/4-M5	φ14	35	φ50	8.0	90	139.5
	φ90	4-M5/4-M6	φ19	38	φ70	8.0	90	143.5

- ✓ PLFS060
- ✓ PLFS090
- ✓ PLFS120
- ✓ PLFS160



PLFS Series

PLFS系列减速机核心特性

The Core Characteristics of PLFS Series Reducer

- 1 采用直齿齿轮传动，经渗碳淬火处理，齿向齿廓修形处理，确保运行平稳，噪音小；
- 2 结构简单，可大批量生产，且交货期快性价比高；
- 3 减速机种类齐全，可以满足市场上绝大多数减速机的配合。

- 1 Adopt straight tooth gear transmission, through carburizing and quenching treatment, tooth profile modification treatment, ensure smooth operation, low noise.
- 2 Simple structure, mass production, and fast delivery time and high cost performance.
- 3 Reducer has a complete range, which can meet the needs of most reducer in the market.

减速机性能资料

Gear box performance information

型号 Model	单位 Unit	PLFS060	PLFS090	PLFS120	PLFS160	减速比 Ratio	Stage
额定输出扭矩 Rated output torque	N·m	16.5	60	148	310	3	1
		27	86	222	605	4	
		27	94.5	235	420	5	
		19.5	64	158	270	7(8)	
		8.5	39.5	93	-	10	2
			96	250	680	12	
			96	250	-	15	
		30	96	250	680	16	
		30	96	250	680	20	
		33	105.5	264	460	25	
		30	96	250	680	28(32)	
		33	105.5	264	-	35	
		30	96	250	460	40	3
		33	105.5	264	-	50	
		21.5	71.5	177	310	70(64)	
		37.5	120	310	900	64	
		37.5	120	310	900	80	
		37.5	120	310	900	100	
		41.0	132.5	329	580	125	
		37.5	120	310	-	140	
41.0	132.5	329	580	175(160)			
37.5	120	310	580	200			
41.0	132.5	329	900	250(256)			
37.5	120	310	580	280(320)			
41.0	132.5	329	400	350(512)			
故障停滞扭矩 Emergency stop torque	N·m	2倍额定输出扭矩 2 times Rated output torque					
额定输入转速 Norminal input speed	rmp	3000	3000	2000	2000		
最大输入转速 Maximum input speed	rmp	6000	6000	3500	3500		
最大径向力 Maximum radial force	N	170	1020	2230	3200		
最大轴向力 Maximum axial force	N	120	850	1550	3000		
效率 Efficiency	%	Single [97%]		Double [95%]			
平均寿命 Average lifetime	h	20000					
重量 Weight	kg	1.4	4.7	6.9	19	1	
		1.6	5.3	8.9	25	2	
		1.8	5.9	11.2	31	3	

减速机性能资料 Gear box performance information

型号 Model	单位 Unit	PLFS060	PLFS090	PLFS120	PLFS160	减速比 Ratio	Stage
转动惯量 Moment of inertia	kgcm ²	0.107	0.4	1.65	4.31	3	1
		0.094	0.309	1.22	5.15	4	
		0.092	0.291	1.15	4.93	5	
		0.091	0.285	1.13	4.84	7(8)	
		0.091	0.283	1.11	-	10	
		2	0.4	1.65	6.31	12	
			0.309	1.65	-	15	
			0.094	0.291	1.22	5.15	16
			0.092	0.291	1.15	4.93	20
			0.092	0.291	1.15	4.93	25
			0.091	0.285	1.13	4.84	28(32)
			0.091	0.285	1.13	-	35
			0.091	0.2835	1.11	4.84	40
			0.091	0.283	1.11	-	50
			0.091	0.283	1.11	4.84	70(64)
			0.092	0.291	1.15	4.93	64
			0.092	0.291	1.15	4.93	80
			0.092	0.291	1.15	4.93	100
			0.092	0.291	1.15	4.84	125
			3	0.091	0.291	1.13	-
0.091	0.291	1.13		4.84	175(160)		
0.091	0.283	1.11		4.84	200		
0.091	0.283	1.11		4.84	250(256)		
0.091	0.283	1.11		4.84	280(320)		
0.091	0.283	1.11	4.84	350(512)			
噪音 Noise	dB	60	65	68	70		
润滑 Lubricating		合成油脂润滑 Synthetic grease lubrication					
防护等级 levels of protection		IP65					

外形尺寸图表 Outline dimensional

PLFS060-L1

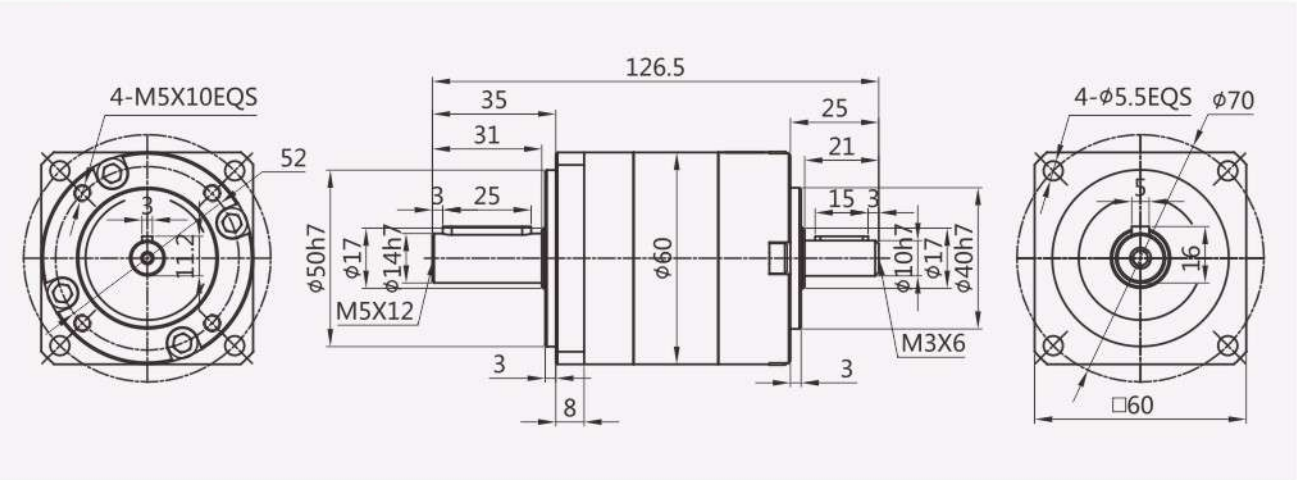

PLFS060-L2

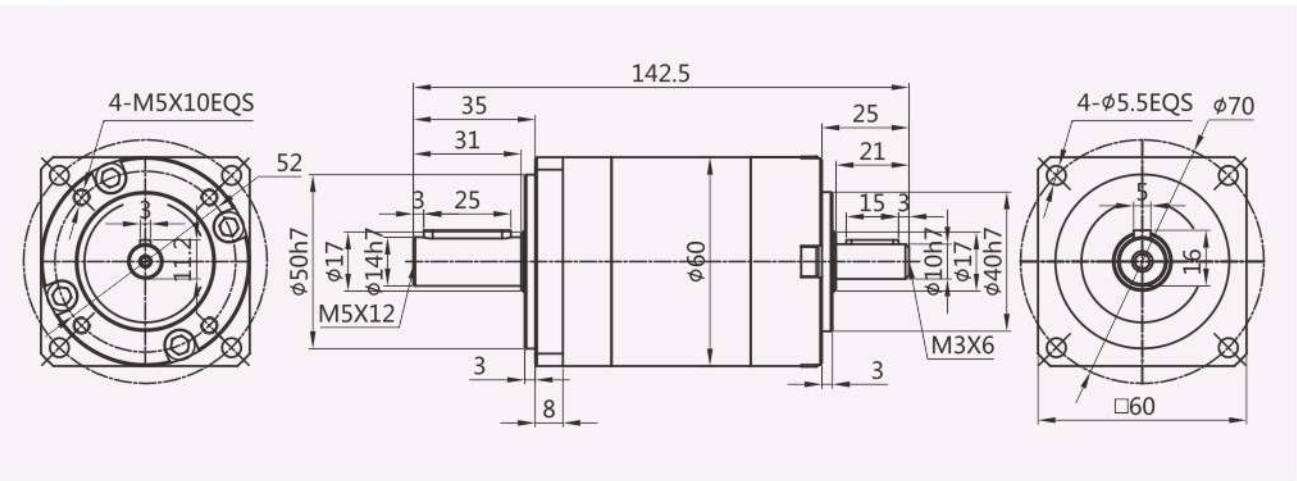

PLFS060-L3

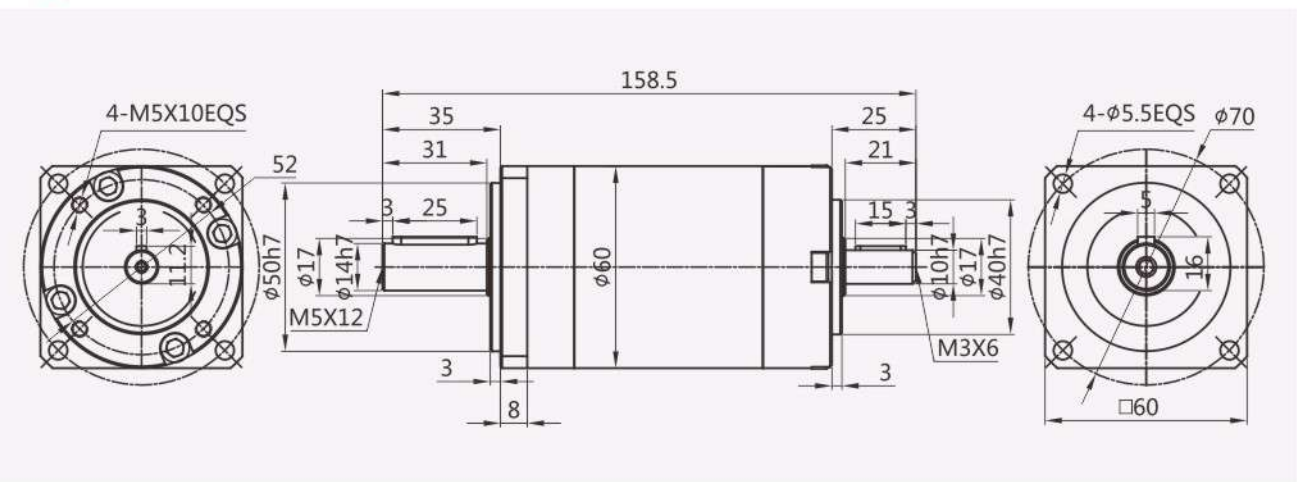

PLFS Series

外形尺寸图表

Outline dimensional

PLFS090-L1

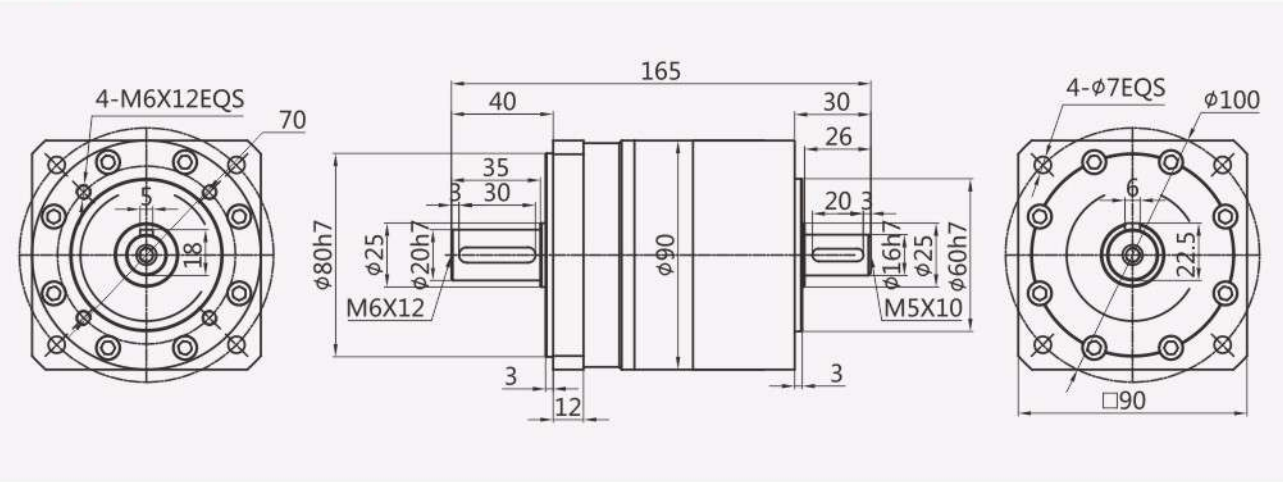

PLFS090-L2

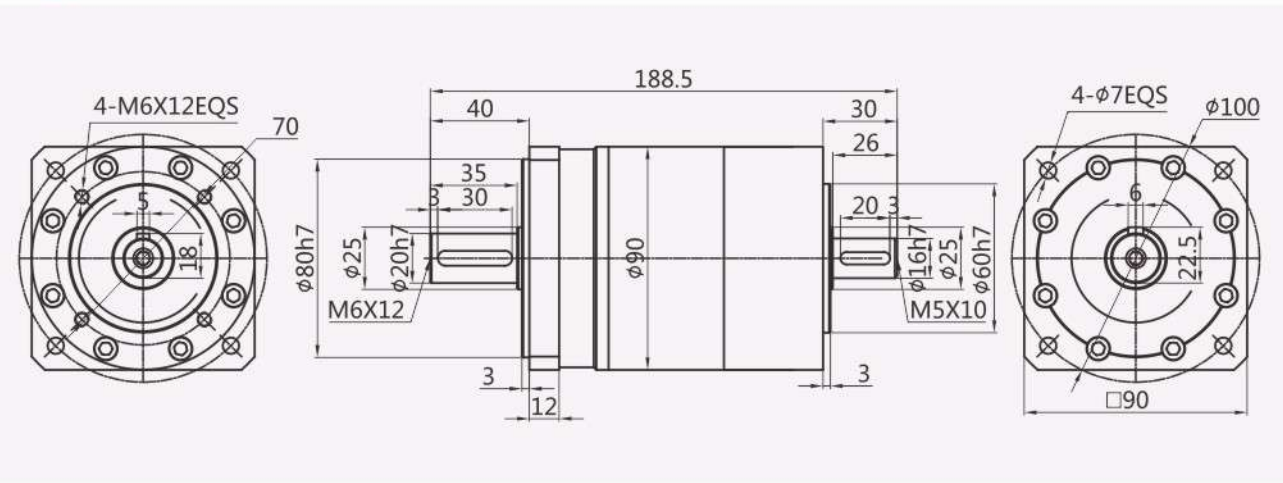

PLFS090-L3

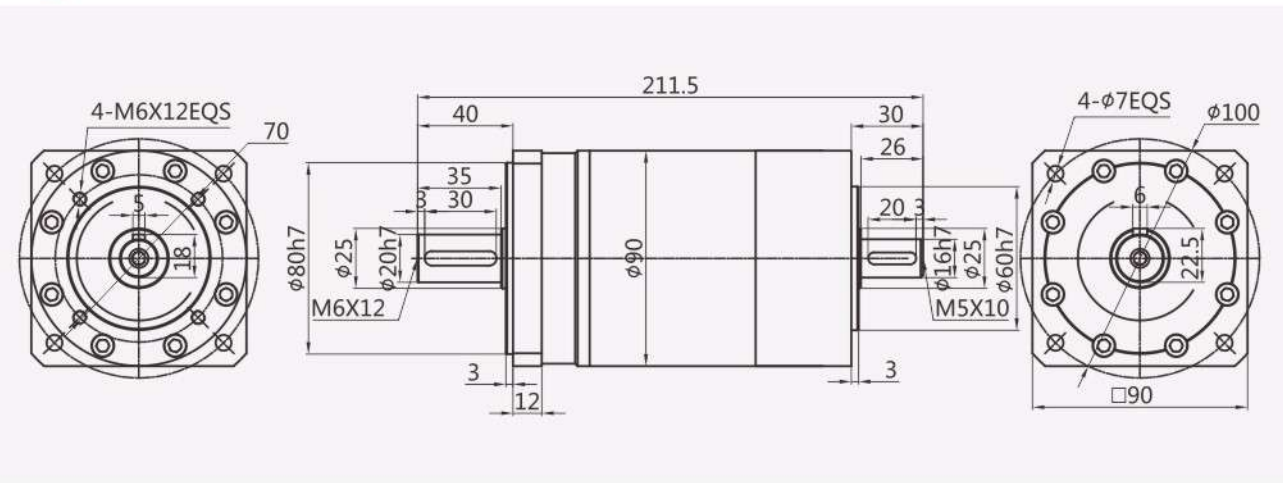

外形尺寸图表

Outline dimensional

PLFS120-L1

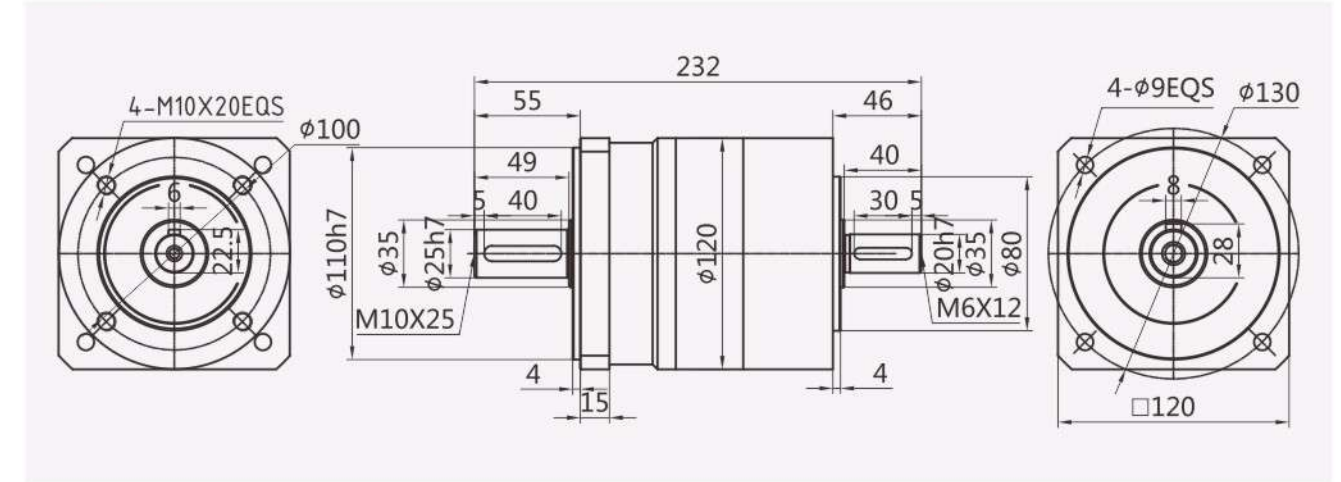

PLFS120-L2

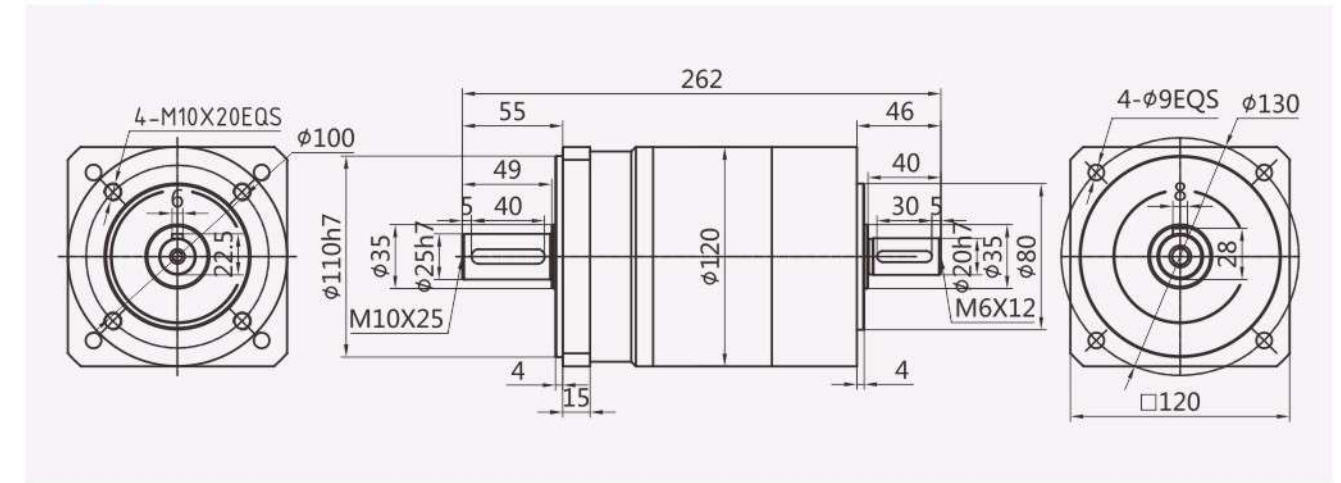

PLFS120-L3

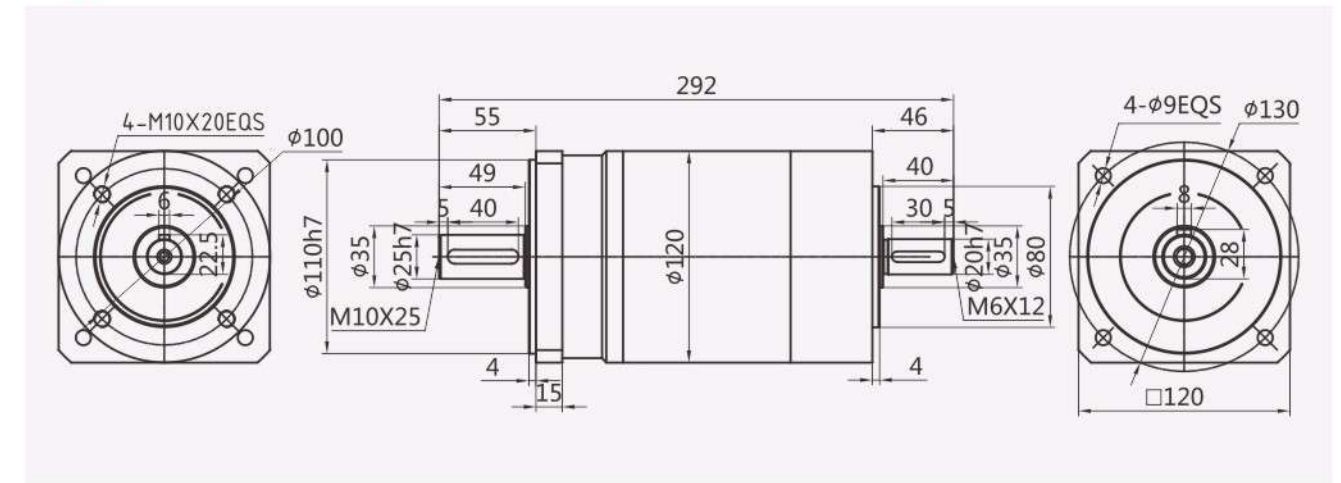

外形尺寸图表

Outline dimensional

PLFS160-L1

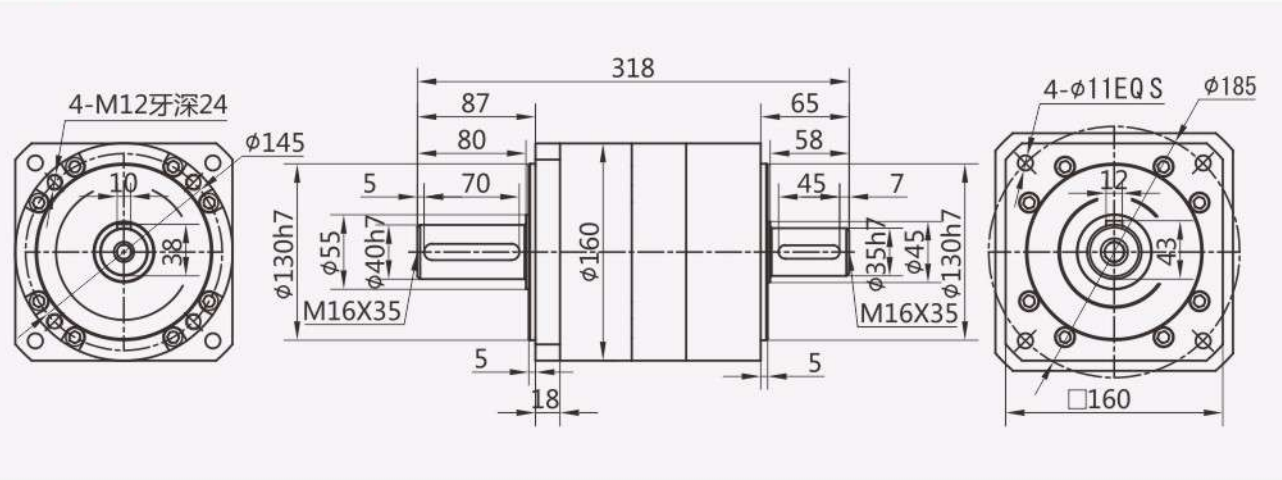

PLFS160-L2

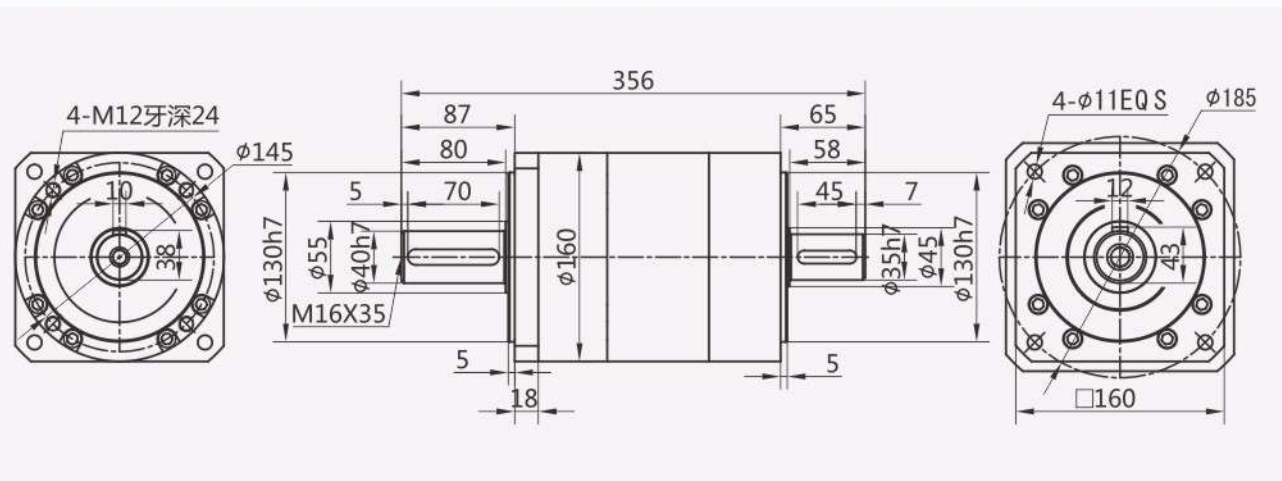

PLFS160-L3

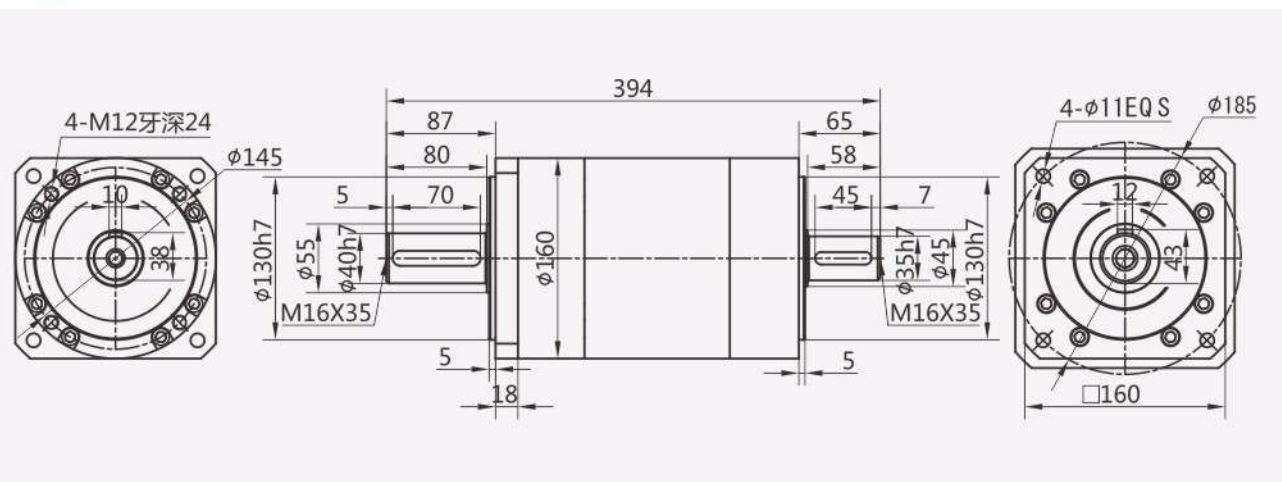

- ✓ PLS060
- ✓ PLS090
- ✓ PLS120
- ✓ PLS160



PLS Series

PLS系列减速机核心特性

The Core Characteristics of PLS Series Reducer

- 1 采用直齿齿轮传动，经渗碳淬火处理，齿向齿廓修形处理，确保运行平稳，噪音小；
- 2 结构简单，可大批量生产，且交货期快性价比高；
- 3 减速机种类齐全，可以满足市场上绝大多数减速机的配合。

- 1 Adopt straight tooth gear transmission, through carburizing and quenching treatment, tooth profile modification treatment, ensure smooth operation, low noise.
- 2 Simple structure, mass production, and fast delivery time and high cost performance.
- 3 Reducer has a complete range, which can meet the needs of most reducer in the market.

减速机性能资料 Gear box performance information

型号 Model	单位 Unit	PLS060	PLS090	PLS120	PLS160	减速比 Ratio	Stage	
额定输出扭矩 Rated output torque	N·m	16.5	60	148	310	3	1	
		27	86	222	605	4		
		27	94.5	235	420	5		
		19.5	64	158	270	7(8)		
		8.5	39.5	93	-	10		
			96	250	680	12	2	
			96	250	-	15		
		30	96	250	680	16		
		30	96	250	680	20		
		33	105.5	264	460	25		
		30	96	250	680	28(32)		
		33	105.5	264	-	35		
		30	96	250	460	40		
		33	105.5	264	-	50		
		21.5	71.5	177	310	70(64)		
		37.5	120	310	900	64	3	
		37.5	120	310	900	80		
		37.5	120	310	900	100		
		41.0	132.5	329	580	125		
		37.5	120	310	-	140		
41.0	132.5	329	580	175(160)				
37.5	120	310	580	200				
41.0	132.5	329	900	250(256)				
37.5	120	310	580	280(320)				
41.0	132.5	329	400	350(512)				
故障停滞扭矩 Emergency stop torque	N·m	2倍额定输出扭矩 2 times Rated output torque						
额定输入转速 Nominal input speed	rmp	3000	3000	2000	2000			
最大输入转速 Maximum input speed	rmp	6000	6000	3500	3500			
最大径向力 Maximum radial force	N	170	1020	2230	3200			
最大轴向力 Maximum axial force	N	120	850	1550	3000			
效率 Efficiency	%	Single [97%]		Double [95%]				
平均寿命 Average lifetime	h	20000						
重量 Weight	kg	1.4	4.7	6.9	19		1	
		1.6	5.3	8.9	25		2	
		1.8	5.9	11.2	31		3	

减速机性能资料 Gear box performance information

型号 Model	单位 Unit	PLS060	PLS090	PLS120	PLS160	减速比 Ratio	Stage
转动惯量 Moment of inertia	kgcm ²	0.107	0.4	1.65	4.31	3	1
		0.094	0.309	1.22	5.15	4	
		0.092	0.291	1.15	4.93	5	
		0.091	0.285	1.13	4.84	7(8)	
		0.091	0.283	1.11	-	10	
			0.4	1.65	6.31	12	2
			0.309	1.65	-	15	
		0.094	0.291	1.22	5.15	16	
		0.092	0.291	1.15	4.93	20	
		0.092	0.291	1.15	4.93	25	
		0.091	0.285	1.13	4.84	28(32)	
		0.091	0.285	1.13	-	35	
		0.091	0.2835	1.11	4.84	40	
		0.091	0.283	1.11	-	50	
		0.091	0.283	1.11	4.84	70(64)	
		0.092	0.291	1.15	4.93	64	3
		0.092	0.291	1.15	4.93	80	
		0.092	0.291	1.15	4.93	100	
		0.092	0.291	1.15	4.84	125	
		0.091	0.291	1.13	-	140	
0.091	0.291	1.13	4.84	175(160)			
0.091	0.283	1.11	4.84	200			
0.091	0.283	1.11	4.84	250(256)			
0.091	0.283	1.11	4.84	280(320)			
0.091	0.283	1.11	4.84	350(512)			
噪音 Noise	dB	60	65	68	70		
润滑 Lubricating		合成油脂润滑 Synthetic grease lubrication					
防护等级 levels of protection		IP65					

外形尺寸图表
Outline dimensional

PLS060-L1

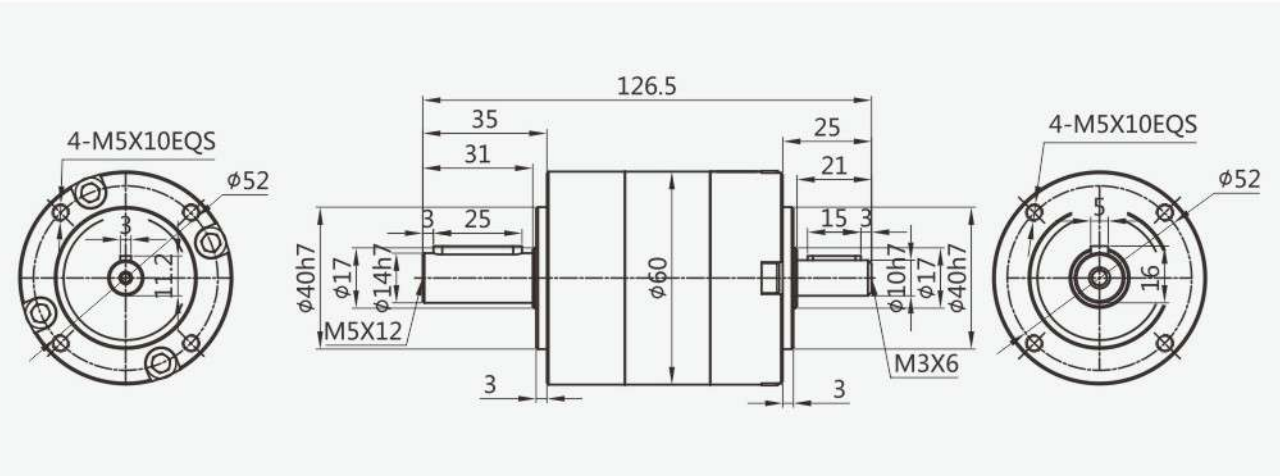

PLS060-L2

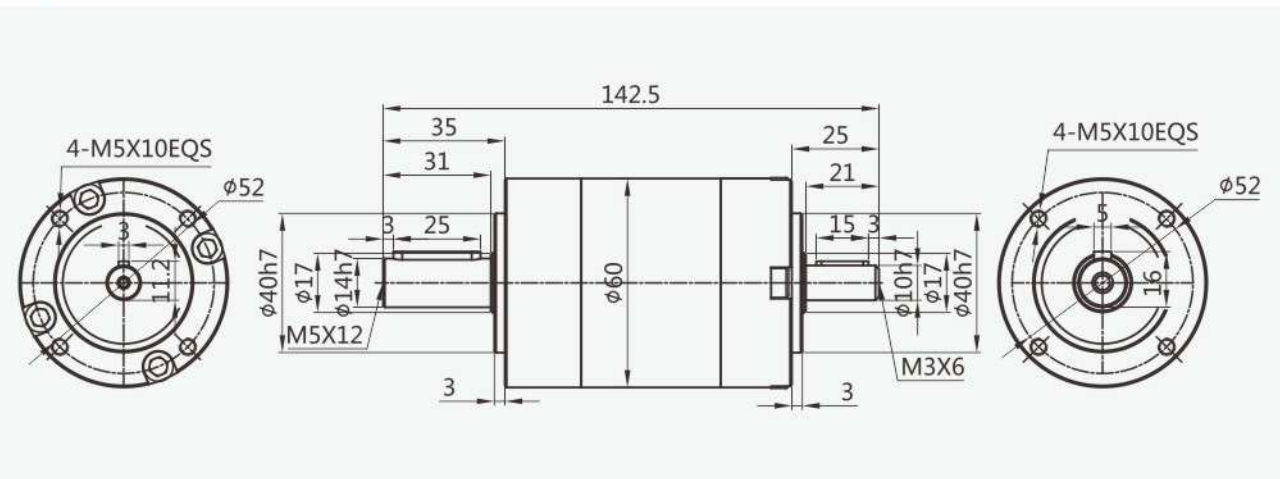

PLS060-L3

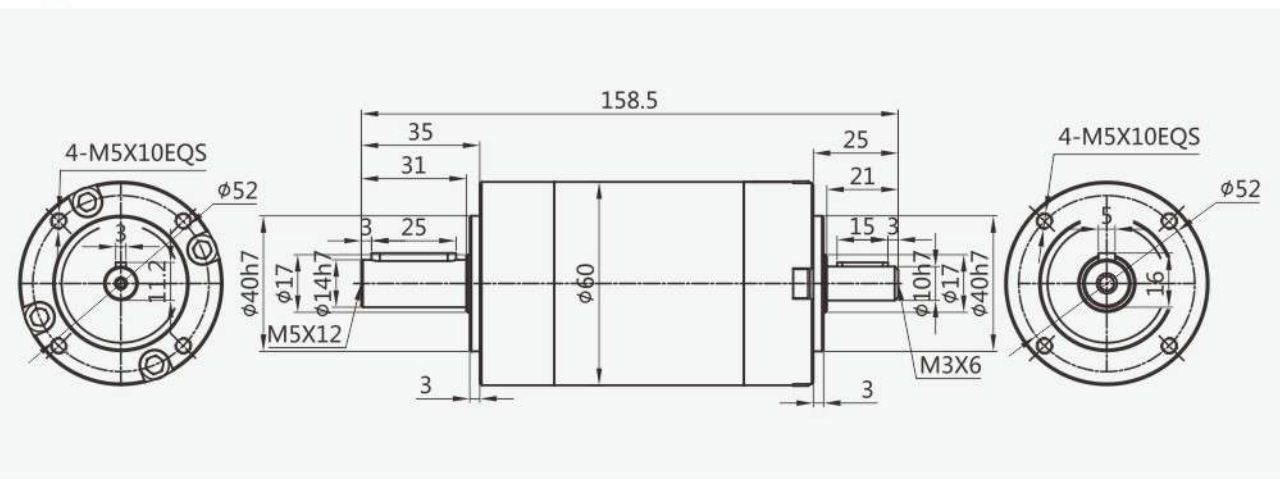

外形尺寸图表
Outline dimensional

PLS090-L1

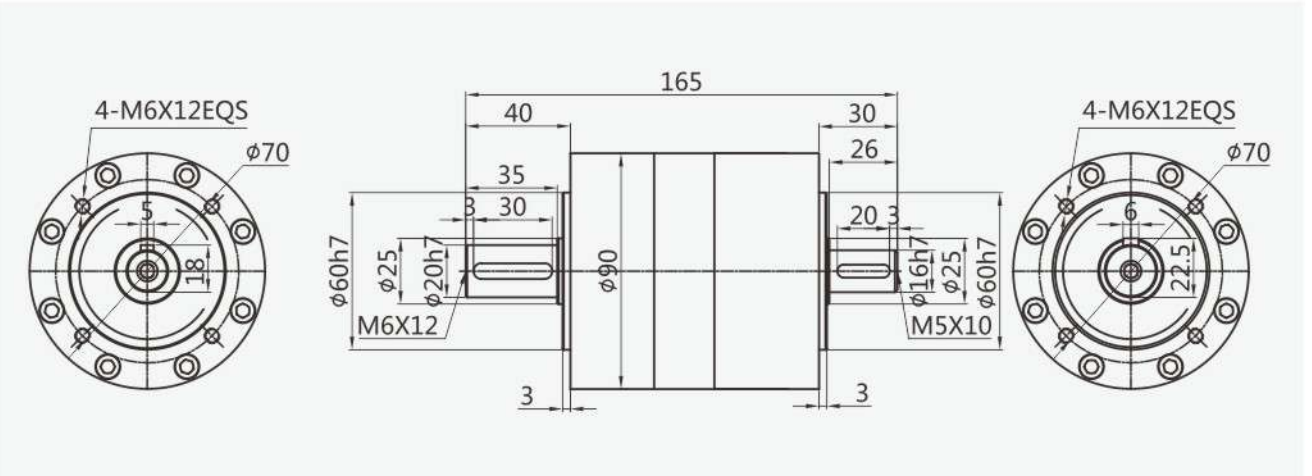

PLS090-L2

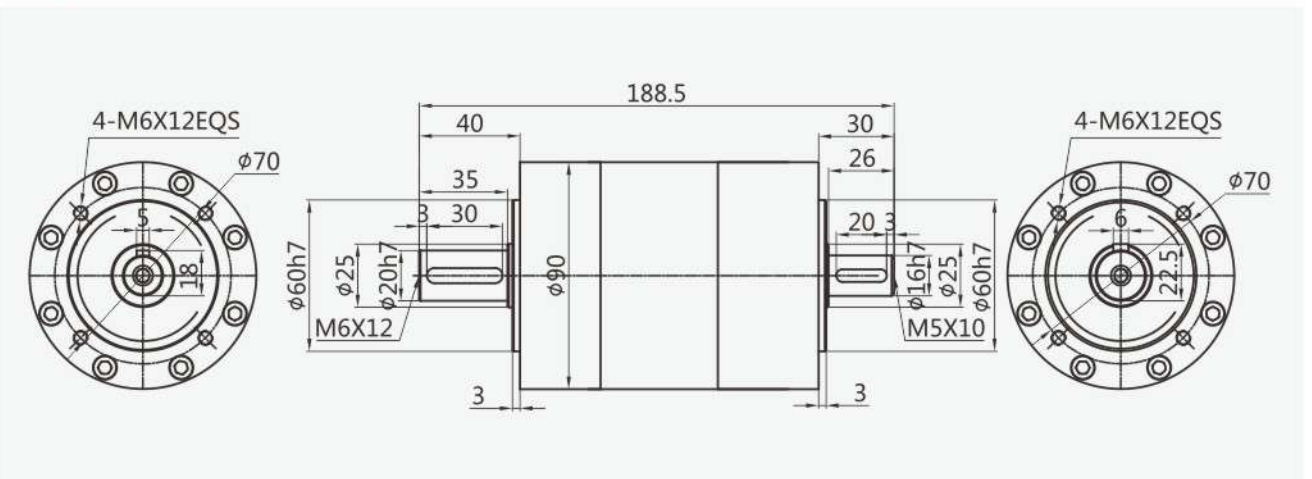

PLS090-L3

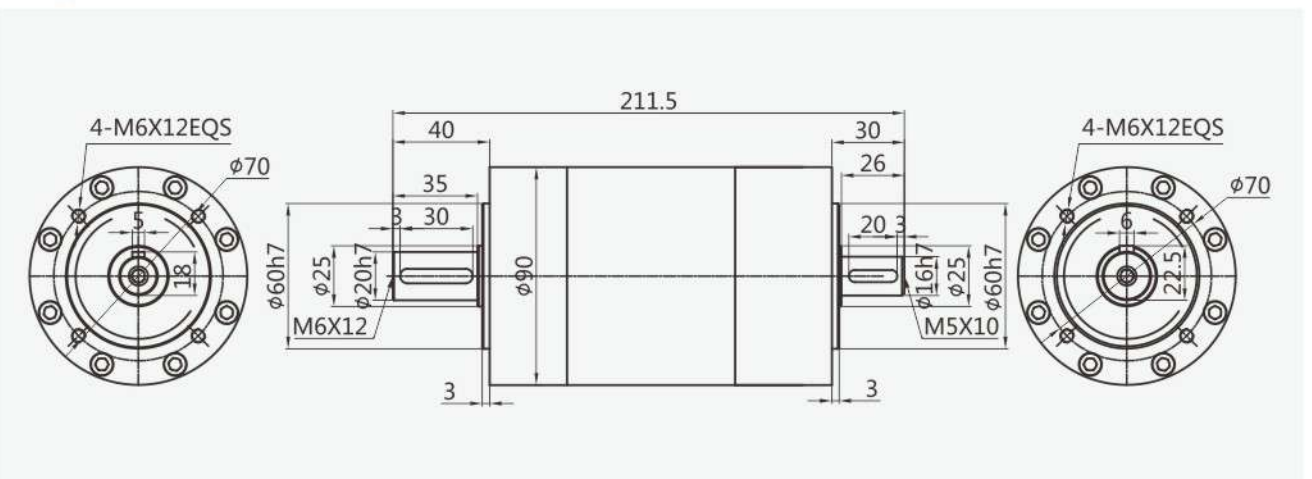

外形尺寸图表
Outline dimensional

PLS120-L1

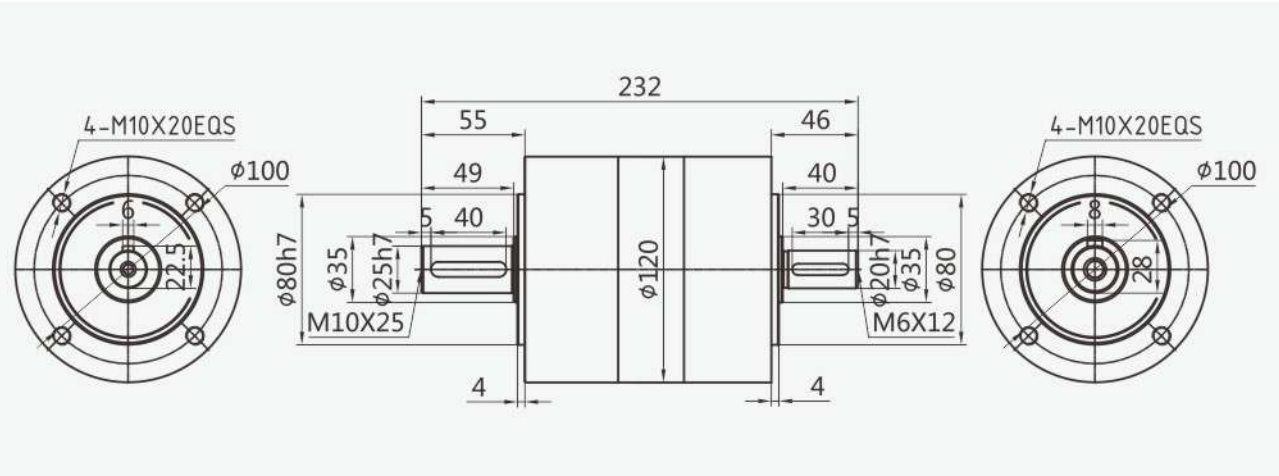

PLS120-L2

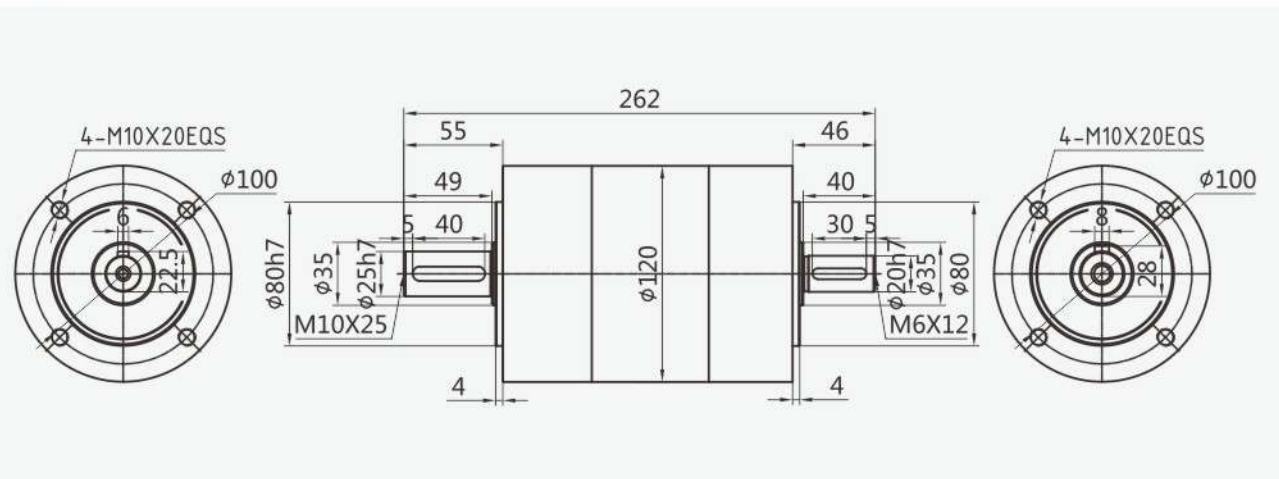

PLS120-L3

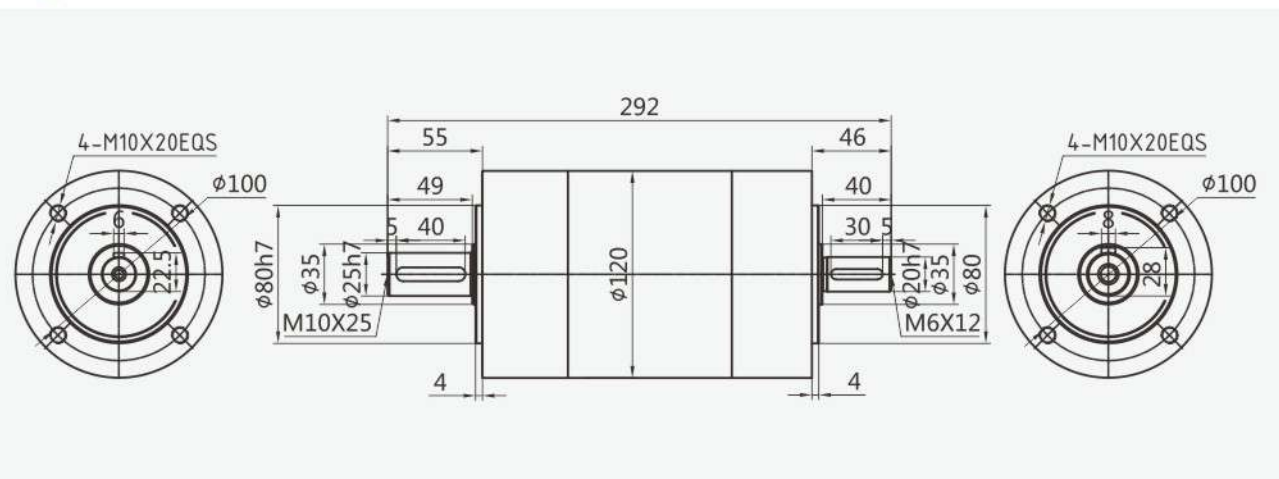

外形尺寸图表
Outline dimensional

PLS160-L1

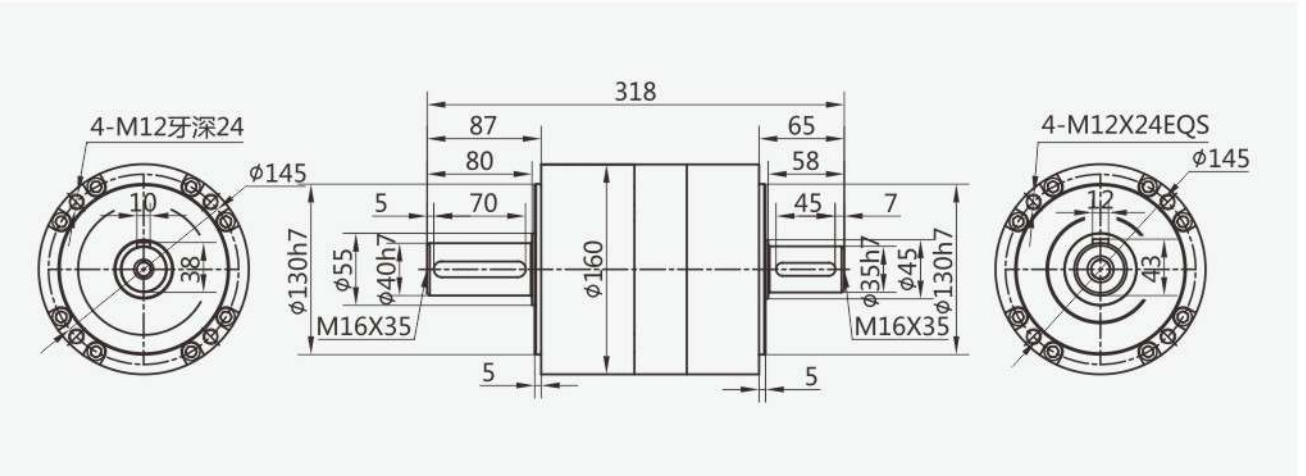

PLS160-L2

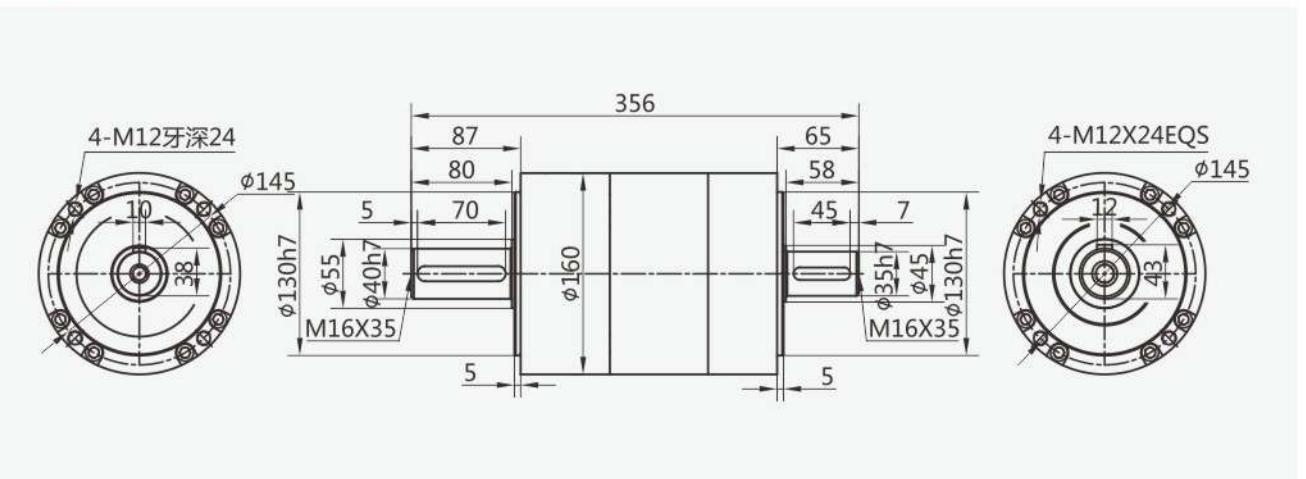

PLS160-L3

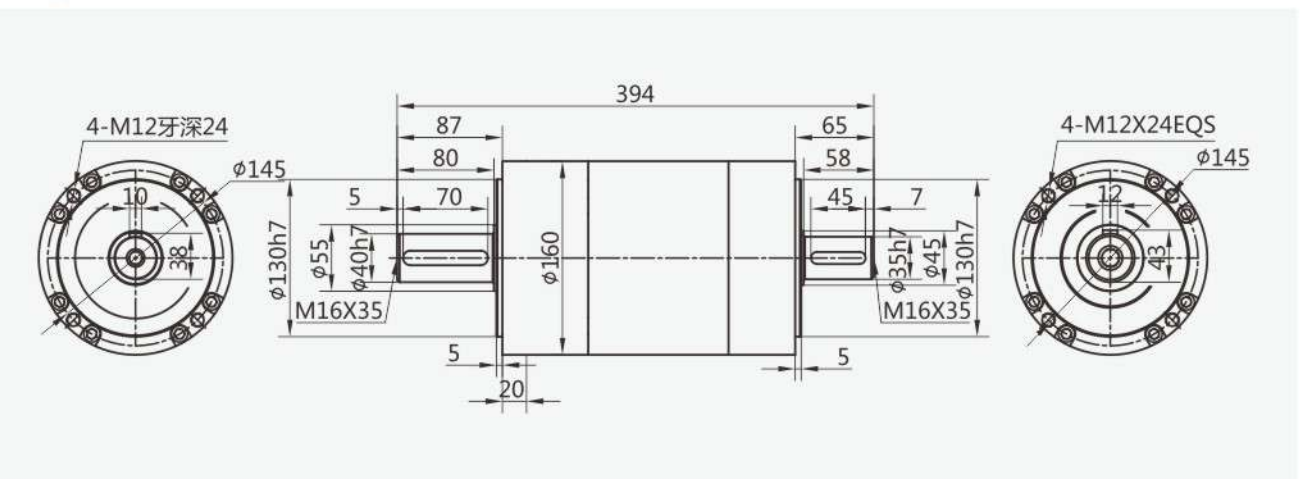

- ✓ PLX042
- ✓ PLX142
- ✓ PLX190
- ✓ PLX242
- ✓ PLX285
- ✓ PLX330

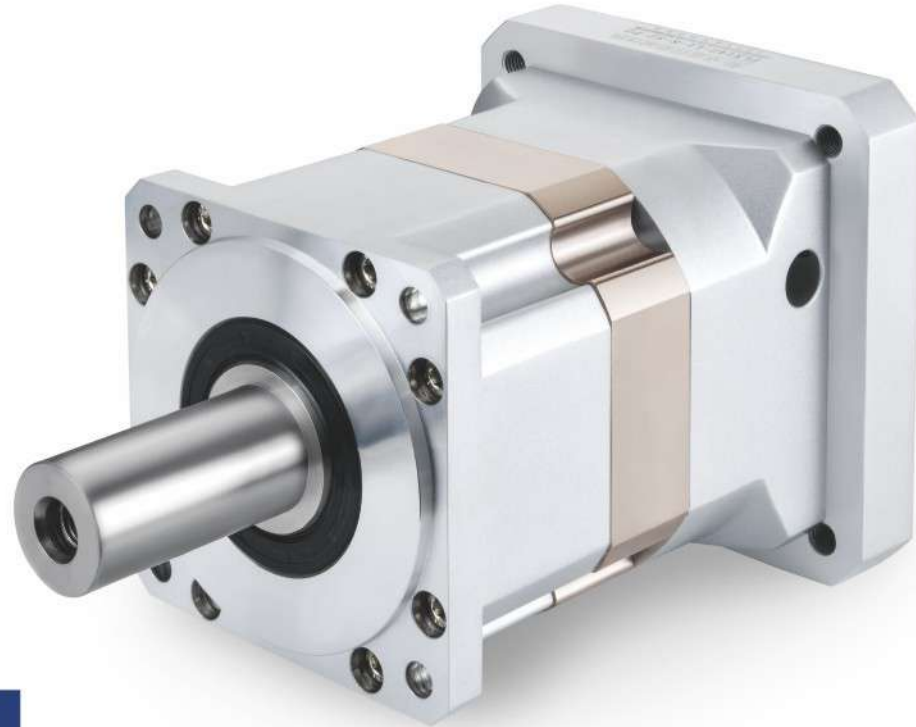

PLX Series

PLX系列减速机核心特性

The Core Characteristics of PLX Series Reducer

- 1 采用直齿齿轮传动，经渗碳淬火处理，齿向齿廓修形处理，确保运行平稳，噪音小；
- 2 结构简单，可大批量生产，且交货期快性价比高；
- 3 减速机种类齐全，可以满足市场上绝大多数减速机的配合。

- 1 Adopt straight tooth gear transmission, through carburizing and quenching treatment, tooth profile modification treatment, ensure smooth operation, low noise.
- 2 Simple structure, mass production, and fast delivery time and high cost performance.
- 3 Reducer has a complete range, which can meet the needs of most reducer in the market.

减速机性能资料

Gear box performance information

型号 Model	单位 Unit	PLX042	PLX142	PLX190	减速比 Ratio	Stage
额定输出扭矩 Rated output torque	N·m	8	310	-	3	1
		9	605	1780	4	
		9	420	1345	5	
		7	270	745	8	2
			680	2035	12	
		12	680	2035	16	
		12	680	2035	20	
		10.5	460	1485	25	
		12	680	2035	32	
		10.5	460	1485	40	
		8	310	840	64	3
		15.5	900	2035	64	
		15.5	900	2590	80	
		15.5	900	2590	100	
		15.5	580	1855	125	
		15.5	580	2590	160	
		13.5	580	1855	200	
		15.5	900	2590	256	
		13.5	580	1855	320	
		9.5	400	1070	512	
故障停滞扭矩 Emergency stop torque	N·m	2倍额定输出扭矩 2 times Rated output torque				
额定输入转速 Norminal input speed	rmp	3000	2000	1500		
最大输入转速 Maximum input speed	rmp	6000	3500	2500		
最大径向力 Maximum radial force	N	185	3200	13000		
最大轴向力 Maximum axial force	N	150	3000	20000		
效率 Efficiency	%	Single [97%]			Double [95%]	
平均寿命 Average lifetime	h	20000				
重量 Weight	kg	0.5	17	42		1
		0.6	23	50		2
		0.7	29	58		3

减速机性能资料 Gear box performance information

型号 Model	单位 Unit	PLX042	PLX142	PLX190	减速比 Ratio	Stage
转动惯量 Moment of inertia	kgcm ²	0.022	4.31	-	3	1
		0.022	5.15	15.6	4	
		0.019	4.93	15.6	5	
		0.017	4.84	15.6	8	
			6.31	6.31	12	
		0.022	5.15	5.15	16	2
		0.019	4.93	4.93	20	
		0.019	4.93	4.93	25	
		0.017	4.84	4.84	32	
		0.016	4.84	4.84	40	
		0.016	4.84	4.84	64	3
		0.019	4.93	4.93	64	
		0.019	4.93	4.93	80	
		0.019	4.93	4.93	100	
		0.029	4.84	4.84	125	
		0.016	4.84	4.84	160	
		0.016	4.84	4.84	200	
		0.016	4.84	4.84	256	
0.016	4.84	4.84	320			
0.016	4.84	4.84	512			
噪音 Noise	dB	60	70	70		
润滑 Lubricating		合成油脂润滑 Synthetic grease lubrication				
防护等级 levels of protection		IP65				

外形尺寸图表 Outline dimensional

PLX-042-L1

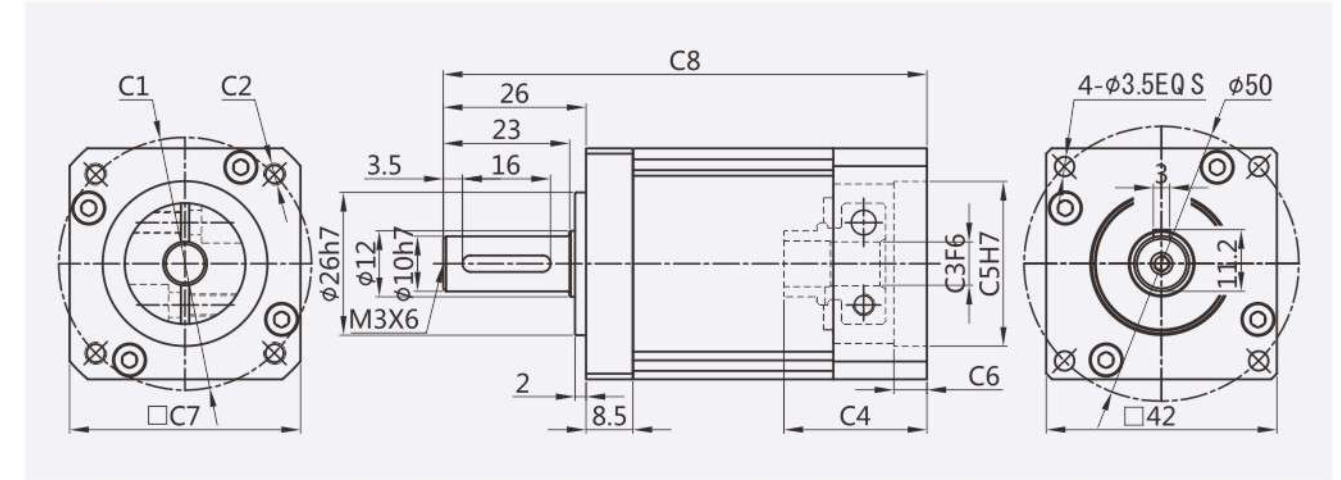

适配电机输入接口尺寸(左端为输入尺寸)
Adapter motor input interface size (The left end is the input size)

尺寸 Size	C1	C2	C3	C4	C5	C6	C7	C8
PLX-042-L1	φ46	4-M4	φ8	26	φ30	6	42	88
	φ45	4-M3	φ8	26	φ30	6	42	88

PLX-042-L2

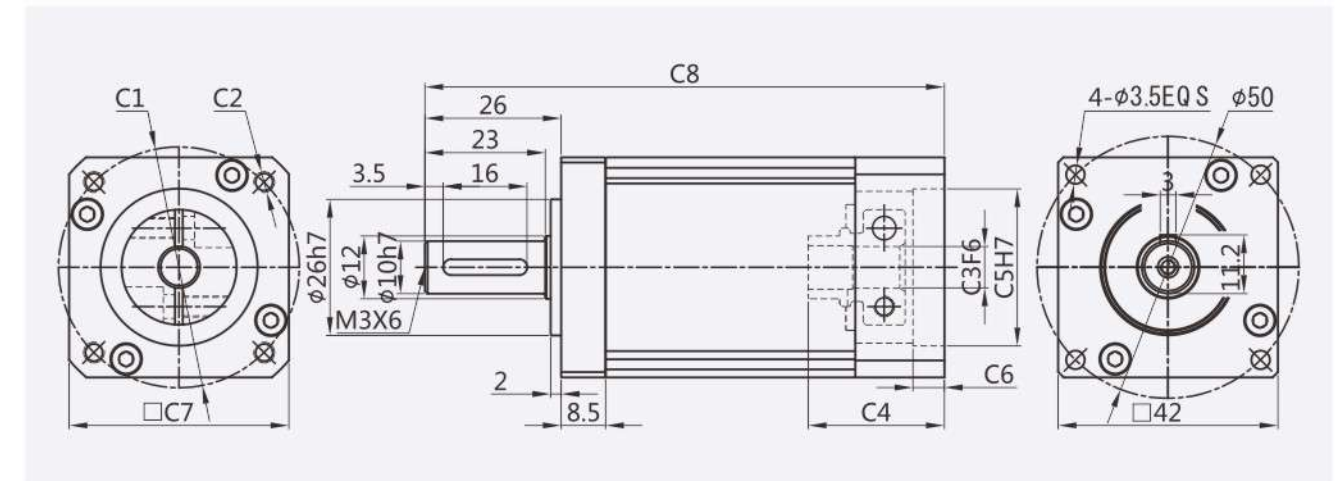

适配电机输入接口尺寸(左端为输入尺寸)
Adapter motor input interface size (The left end is the input size)

尺寸 Size	C1	C2	C3	C4	C5	C6	C7	C8
PLX-042-L2	φ46	4-M4	φ8	26	φ30	6	42	99.2
	φ45	4-M3	φ8	26	φ30	6	42	99.2

外形尺寸图表

Outline dimensional

PLX-042-L3

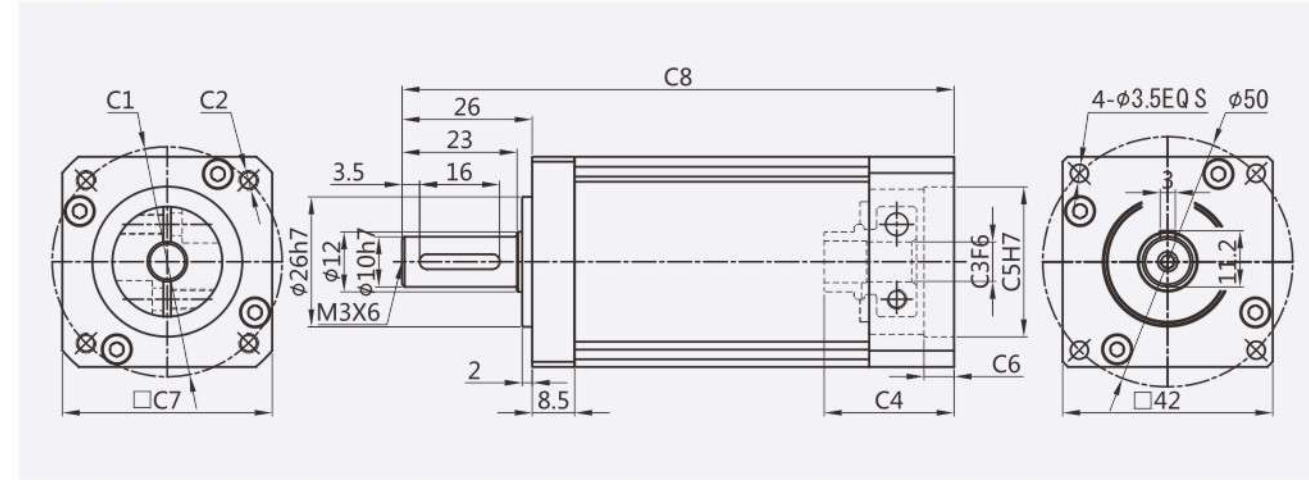

适配电机输入接口尺寸(左端为输入尺寸)

Adapter motor input interface size (The left end is the input size)

尺寸 Size	C1	C2	C3	C4	C5	C6	C7	C8
PLX-042-L3	φ46	4-M4	φ8	26	φ30	6	42	110.4
	φ45	4-M3	φ8	26	φ30	6	42	110.4

PLX-142-L1

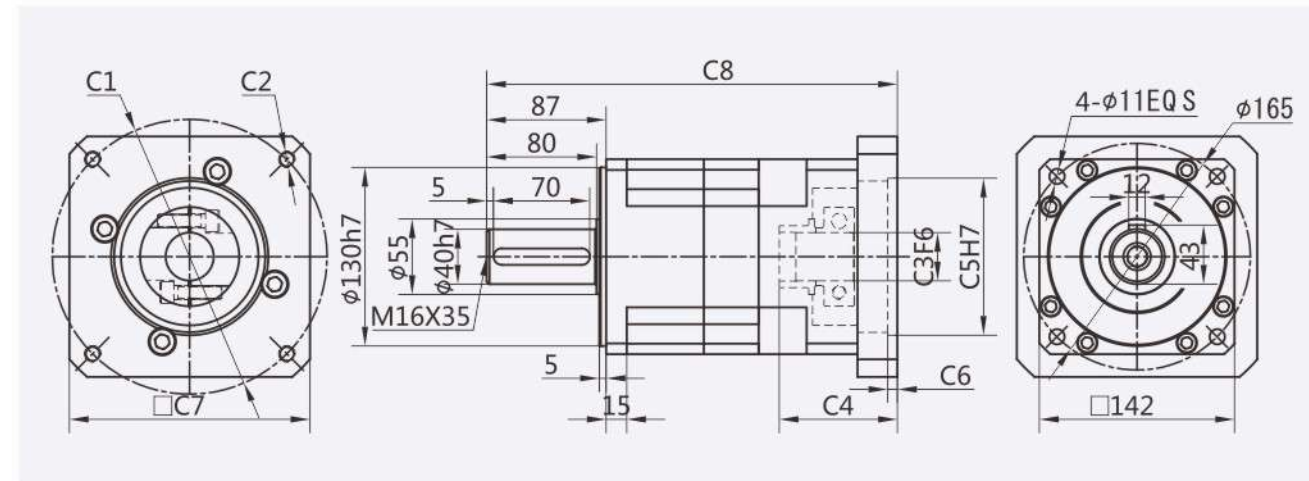

适配电机输入接口尺寸(左端为输入尺寸)

Adapter motor input interface size (The left end is the input size)

尺寸 Size	C1	C2	C3	C4	C5	C6	C7	C8
PLX-142-L1	φ130	4-M8	φ22	62	φ95	7	142	275
	φ145	4-M8	φ22/φ24	62	φ110	7	142	275
	φ165	4-M10	φ32	62	φ130	7	142	275
	φ200	4-M12	φ35	86	φ114.3	7	175	299
	φ200	4-M12	φ35	117	φ114.3	7	175	330
	φ215	4-M12	φ38/φ42	86	φ180	7	190	299

外形尺寸图表

Outline dimensional

PLX-142-L2

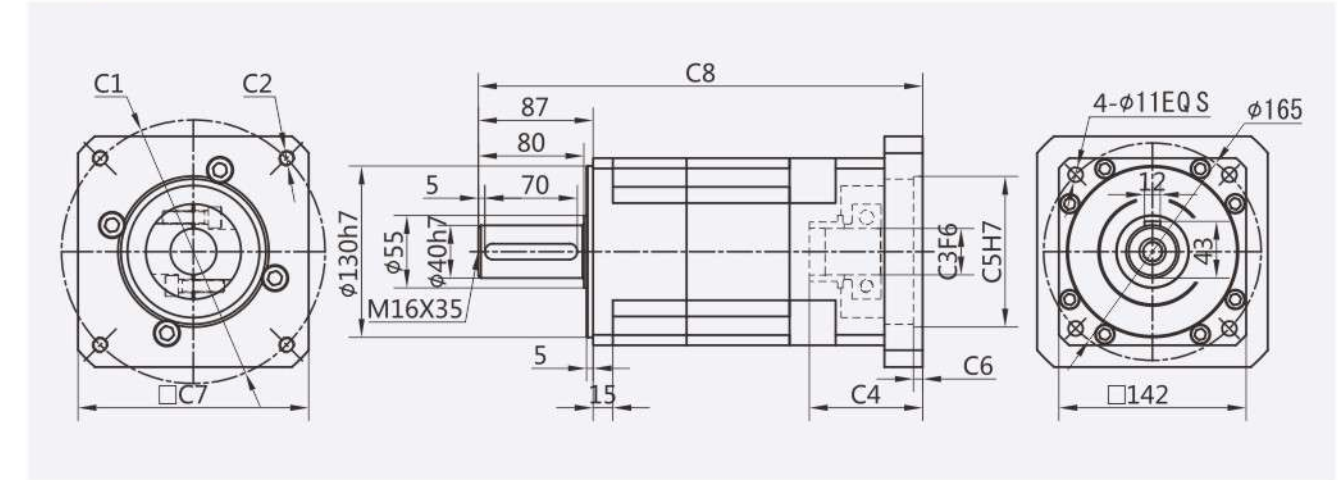

适配电机输入接口尺寸(左端为输入尺寸)

Adapter motor input interface size (The left end is the input size)

尺寸 Size	C1	C2	C3	C4	C5	C6	C7	C8
PLX-142-L2	φ130	4-M8	φ22	62	φ95	7	142	313
	φ145	4-M8	φ22/φ24	62	φ110	7	142	313
	φ165	4-M10	φ32	62	φ130	7	142	313
	φ200	4-M12	φ35	86	φ114.3	7	175	337
	φ200	4-M12	φ35	117	φ114.3	7	175	368
	φ215	4-M12	φ38/φ42	86	φ180	7	190	337

PLX-142-L3

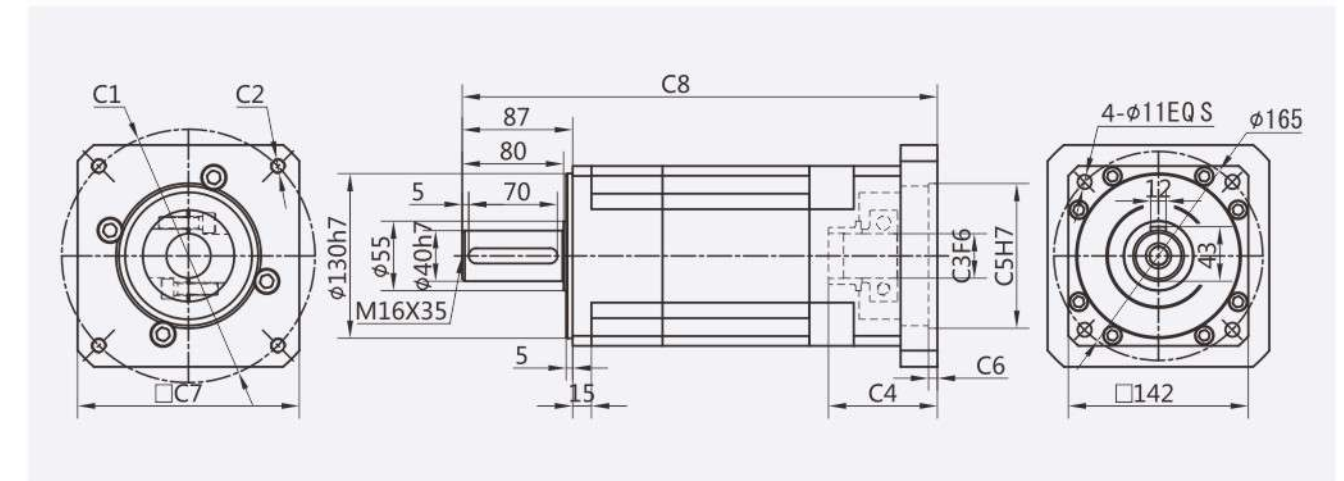

适配电机输入接口尺寸(左端为输入尺寸)

Adapter motor input interface size (The left end is the input size)

尺寸 Size	C1	C2	C3	C4	C5	C6	C7	C8
PLX-142-L3	φ130	4-M8	φ22	62	φ95	7	142	351
	φ145	4-M8	φ22/φ24	62	φ110	7	142	351
	φ165	4-M10	φ32	62	φ130	7	142	351
	φ200	4-M12	φ35	86	φ114.3	7	175	375
	φ200	4-M12	φ35	117	φ114.3	7	175	406
	φ215	4-M12	φ38/φ42	86	φ180	7	190	375

外形尺寸图表

Outline dimensional

PLX-190-L1

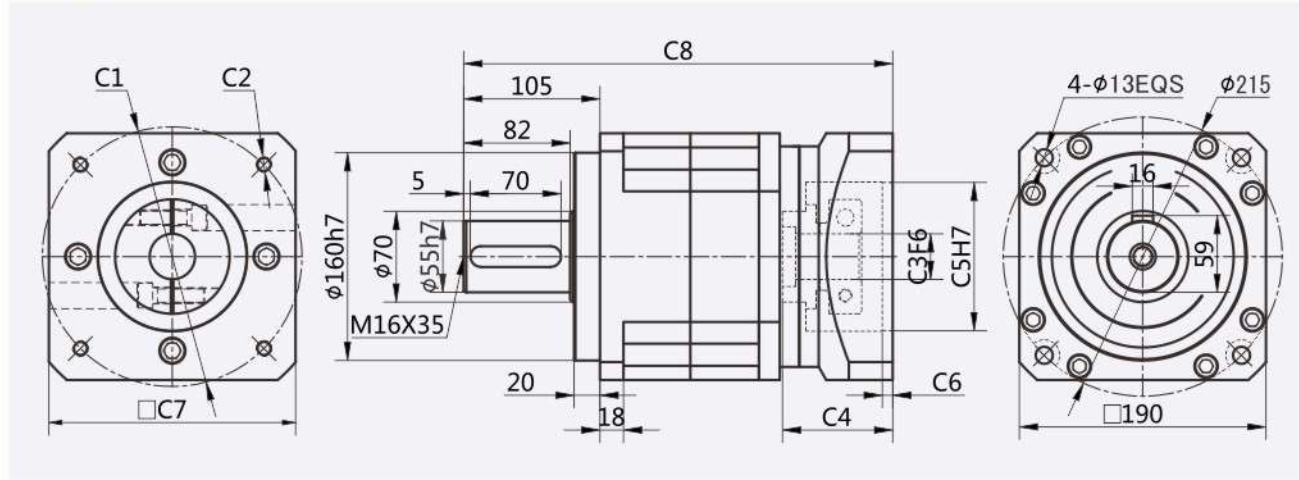

适配电机输入接口尺寸(左端为输入尺寸)

Adapter motor input interface size (The left end is the input size)

尺寸 Size	C1	C2	C3	C4	C5	C6	C7	C8
PLX-190-L1	$\phi 215$	4-M12	$\phi 38/\phi 42$	85	$\phi 180$	7	150	159.5
	$\phi 200$	4-M12	$\phi 35$	115	$\phi 114.3$	7	150	159.5
	$\phi 235$	4-M12	$\phi 38/\phi 42$	120	$\phi 200$	7	150	184.5
	$\phi 200$	4-M12	$\phi 35$	85	$\phi 114.3$	7	180	184.5

PLX-190-L2

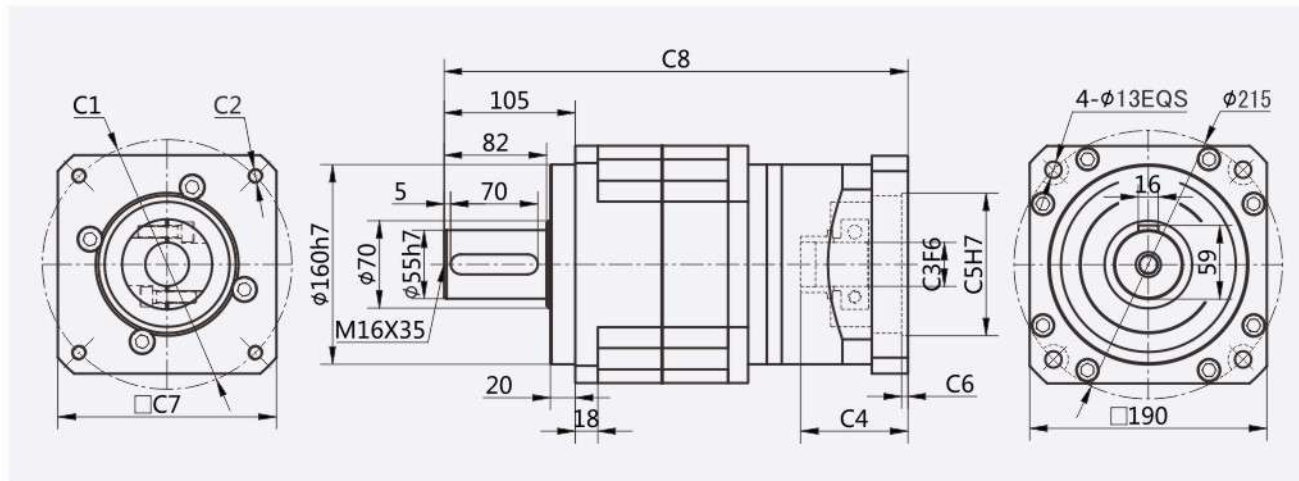

适配电机输入接口尺寸(左端为输入尺寸)

Adapter motor input interface size (The left end is the input size)

尺寸 Size	C1	C2	C3	C4	C5	C6	C7	C8
PLX-190-L2	$\phi 130$	4-M8	$\phi 22$	62	$\phi 95$	7	142	351
	$\phi 145$	4-M8	$\phi 22/\phi 24$	62	$\phi 110$	7	142	351
	$\phi 165$	4-M10	$\phi 32$	62	$\phi 130$	7	142	351
	$\phi 200$	4-M12	$\phi 35$	86	$\phi 114.3$	7	175	375
	$\phi 200$	4-M12	$\phi 35$	117	$\phi 114.3$	7	175	406
	$\phi 215$	4-M12	$\phi 38/\phi 42$	86	$\phi 180$	7	190	375

外形尺寸图表

Outline dimensional

PLX-190-L3

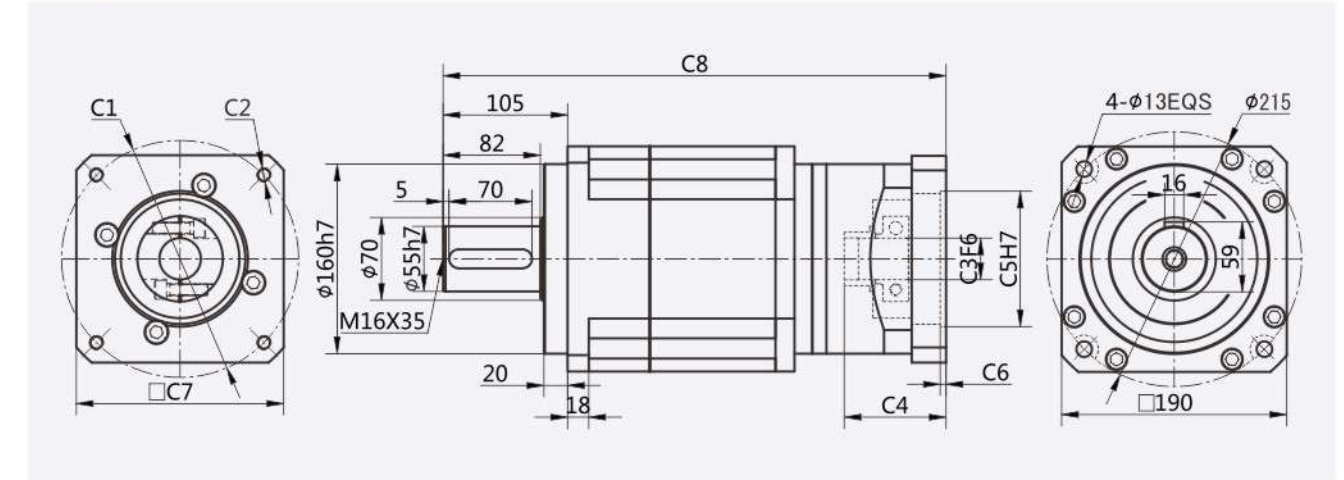

适配电机输入接口尺寸(左端为输入尺寸)

Adapter motor input interface size (The left end is the input size)

尺寸 Size	C1	C2	C3	C4	C5	C6	C7	C8
PLX-190-L3	$\phi 130$	4-M8	$\phi 22$	62	$\phi 95$	7	142	351
	$\phi 145$	4-M8	$\phi 22/\phi 24$	62	$\phi 110$	7	142	351
	$\phi 165$	4-M10	$\phi 32$	62	$\phi 130$	7	142	351
	$\phi 200$	4-M12	$\phi 35$	86	$\phi 114.3$	7	175	375
	$\phi 200$	4-M12	$\phi 35$	117	$\phi 114.3$	7	175	406
	$\phi 215$	4-M12	$\phi 38/\phi 42$	86	$\phi 180$	7	190	375

减速机性能资料

Gear box performance information

型号 Model	单位 Unit	PLX242	PLX285	PLX330	减速比 Ratio	Stage
额定输出扭矩 Rated output torque	N·m	3200	5800	10190	4	1
		2500	4400	7180	5	
		1360	2595	4080	8	
		3390	6400	10800	16	2
		3390	6400	10800	20	
		2650	4710	7550	25	
		3390	6400	10800	32	
		2650	4710	7550	40	
		1450	4710	4430	64	
		3390	8130	13700	64	3
		4420	8130	13700	80	
		3420	9130	13700	100	
		3420	6030	9800	125	
		4420	8130	13700	160	
		3420	6030	9800	200	
		4420	6030	9800	256	
		3420	6030	9800	320	
		1840	3560	8450	512	
故障停滞扭矩 Emergency stop torque	N·m	2倍额定输出扭矩 2 times Rated output torque				
额定输入转速 Nominal input speed	rmp	1000	1000	1000		
最大输入转速 Maximum input speed	rmp	1500	1500	1500		
最大径向力 Maximum radial force	N	12000	15000	17000		
最大轴向力 Maximum axial force	N	6400	12000	15000		
效率 Efficiency	%	Single [97%]			Double [95%]	
平均寿命 Average lifetime	h	20000				
重量 Weight	kg	71	113	245		1
		75	136	290		2
		92	140	326		3

减速机性能资料

Gear box performance information

型号 Model	单位 Unit	PLX242	PLX285	PLX330	减速比 Ratio	Stage
转动惯量 Moment of inertia	kgcm ²	34.6	34.5	65.4	4	1
		34.6	34.5	65.4	5	
		34.6	34.5	65.4	8	
		15.6	38.5	68.5	16	
		15.6	38.5	68.5	20	
		15.6	38.5	68.5	25	
		15.6	38.5	68.5	32	
		15.6	38.5	68.5	40	
		15.6	38.5	68.5	64	
		15.6	38.5	73.4	64	3
		15.6	38.5	73.4	80	
		15.6	38.5	73.4	100	
		15.6	38.5	73.4	125	
		15.6	38.5	73.4	160	
		15.6	38.5	73.4	200	
		15.6	38.5	73.4	256	
		15.6	38.5	73.4	320	
		15.6	38.5	73.4	512	
噪音 Noise	dB	70	70	70		
润滑 Lubricating		合成油脂润滑 Synthetic grease lubrication				
防护等级 levels of protection		IP65				

外形尺寸图表

Outline dimensional

PLX-242-L1

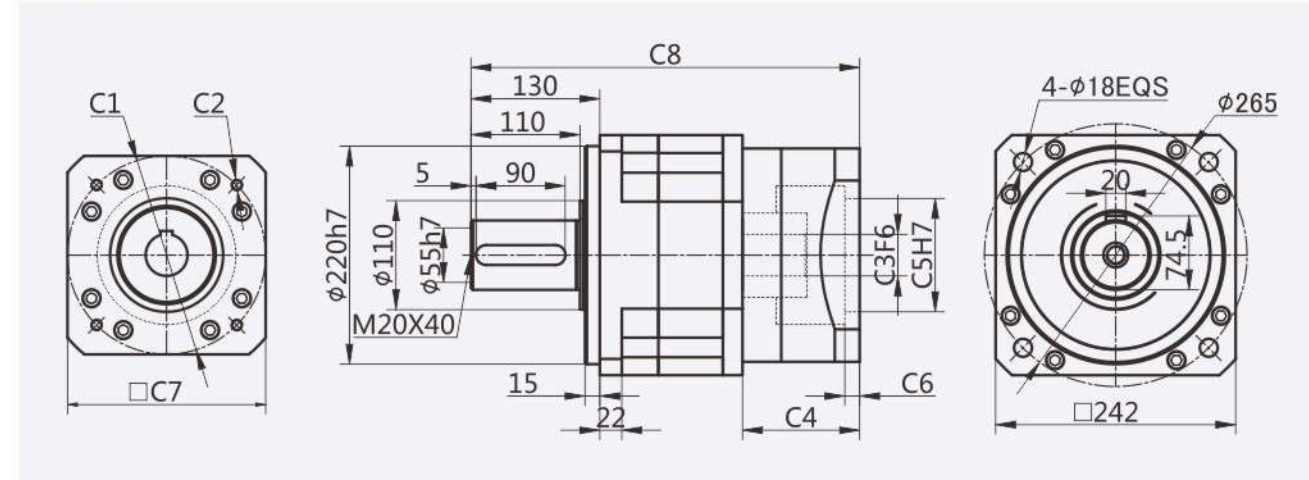

适配电机输入接口尺寸(左端为输入尺寸)

Adapter motor input interface size (The left end is the input size)

尺寸 Size	C1	C2	C3	C4	C5	C6	C7	C8
PLX-242-L1	φ200	4-M12	φ42	118	φ114.3	15	220	392
	φ235	4-M12	φ42	118	φ200	15	220	392

PLX-242-L2

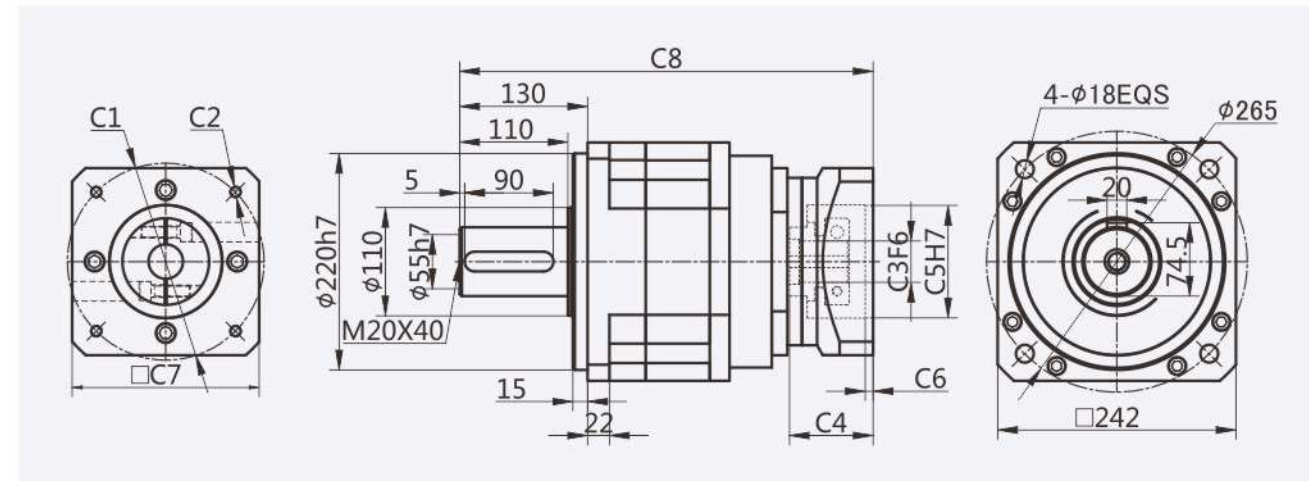

适配电机输入接口尺寸(左端为输入尺寸)

Adapter motor input interface size (The left end is the input size)

尺寸 Size	C1	C2	C3	C4	C5	C6	C7	C8
PLX-242-L2	φ215	4-M12	φ38/φ42	85	φ180	7	150	420
	φ200	4-M12	φ35	115	φ114.3	7	150	450
	φ235	4-M12	φ38/φ42	120	φ200	7	150	455
	φ200	4-M12	φ35	85	φ114.3	7	180	420

外形尺寸图表

Outline dimensional

PLX-242-L3

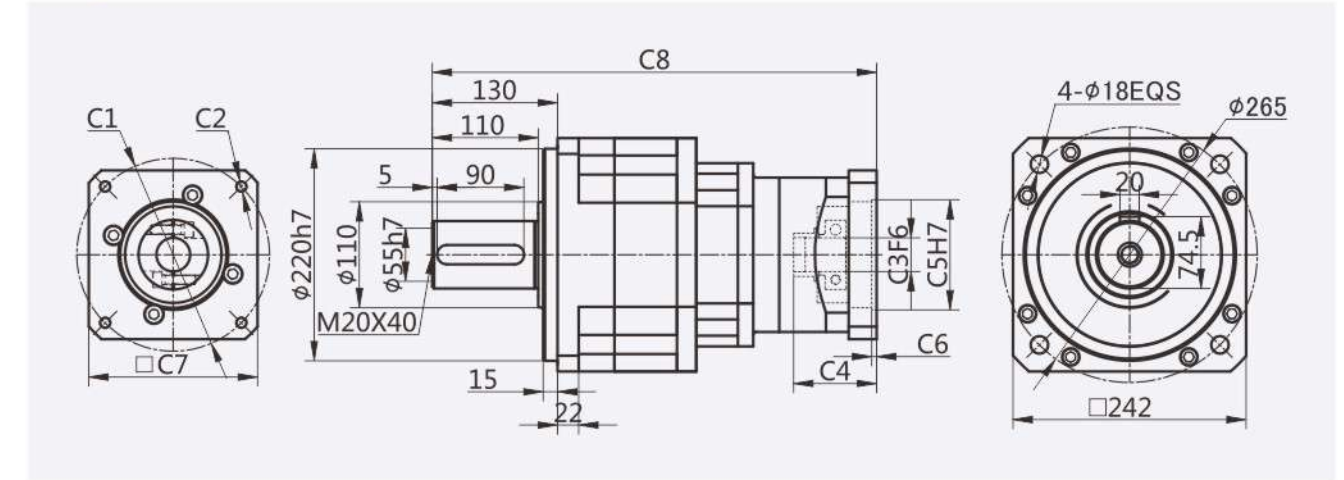

适配电机输入接口尺寸(左端为输入尺寸)

Adapter motor input interface size (The left end is the input size)

尺寸 Size	C1	C2	C3	C4	C5	C6	C7	C8
PLX-242-L3	φ130	4-M8	φ22	62	φ95	7	142	437
	φ145	4-M8	φ22/φ24	62	φ110	7	142	437
	φ165	4-M10	φ32	62	φ130	7	142	437
	φ200	4-M12	φ35	86	φ114.3	7	175	461
	φ200	4-M12	φ35	117	φ114.3	7	175	492

PLX-285-L1

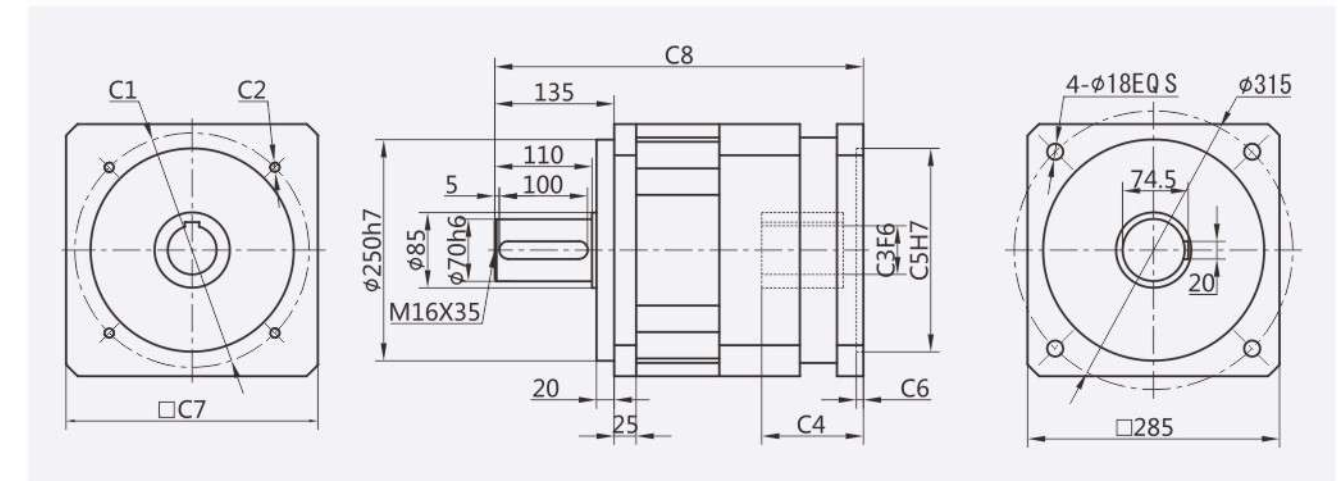

适配电机输入接口尺寸(左端为输入尺寸)

Adapter motor input interface size (The left end is the input size)

尺寸 Size	C1	C2	C3	C4	C5	C6	C7	C8
PLX-285-L1	φ235	4-M12	φ55	115	φ200	7	285	417

外形尺寸图表

Outline dimensional

PLX-285-L2

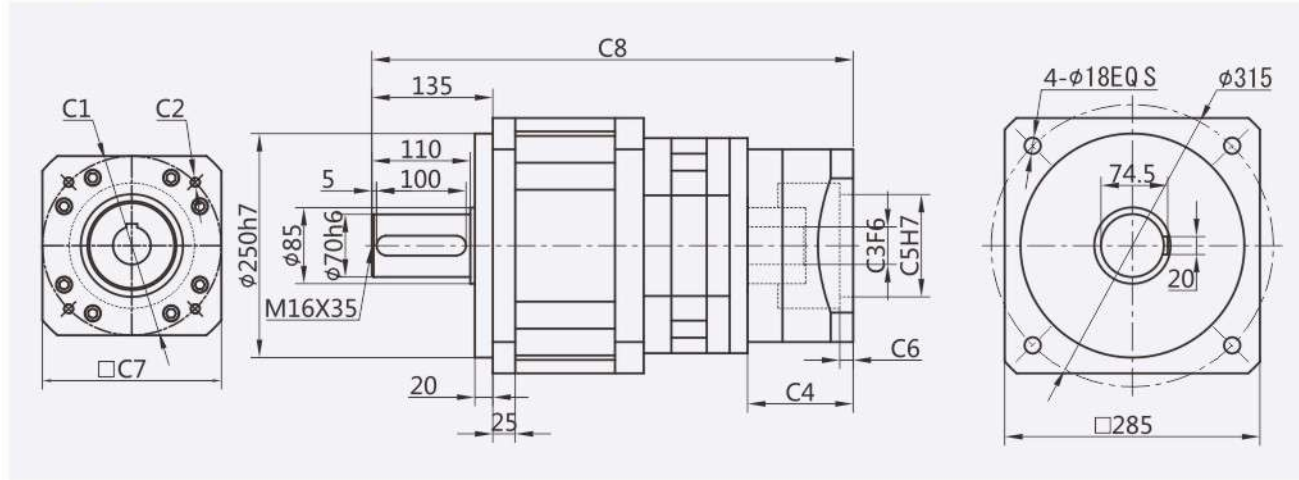

适配电机输入接口尺寸(左端为输入尺寸)

Adapter motor input interface size (The left end is the input size)

尺寸 Size	C1	C2	C3	C4	C5	C6	C7	C8
PLX-285-L2	φ200	4-M12	φ42	118	φ114.3	15	220	537.5
	φ235	4-M12	φ42	118	φ200	15	220	537.5

PLX-285-L3

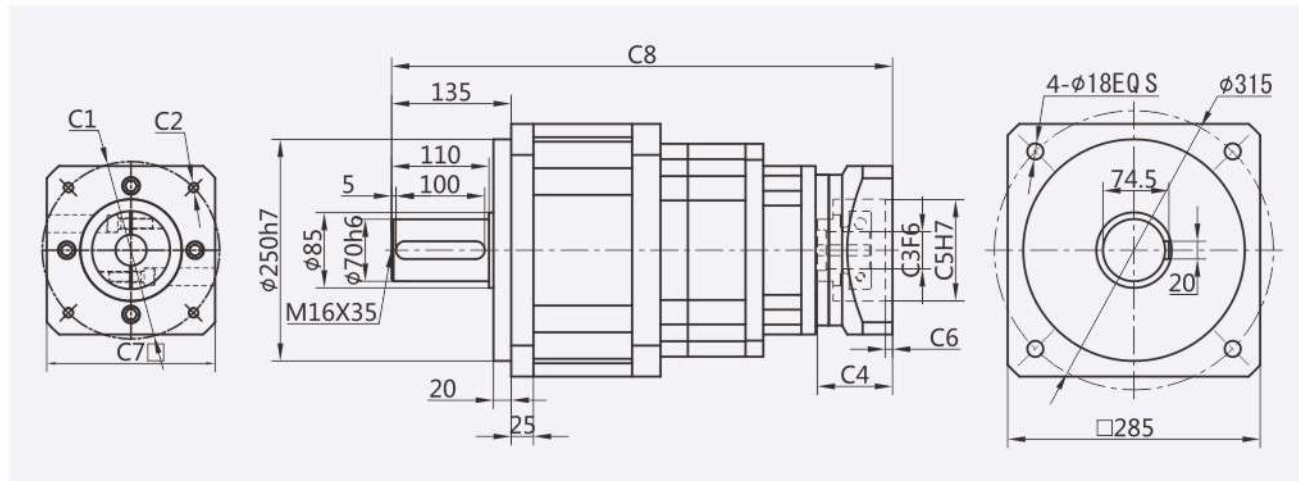

适配电机输入接口尺寸(左端为输入尺寸)

Adapter motor input interface size (The left end is the input size)

尺寸 Size	C1	C2	C3	C4	C5	C6	C7	C8
PLX-285-L3	φ215	4-M12	φ38/φ42	85	φ180	7	150	565.5
	φ200	4-M12	φ35	115	φ114.3	7	150	595.5
	φ235	4-M12	φ38/φ42	120	φ200	7	150	600.5
	φ200	4-M12	φ35	85	φ114.3	7	180	565.5

外形尺寸图表

Outline dimensional

PLX-330-L1

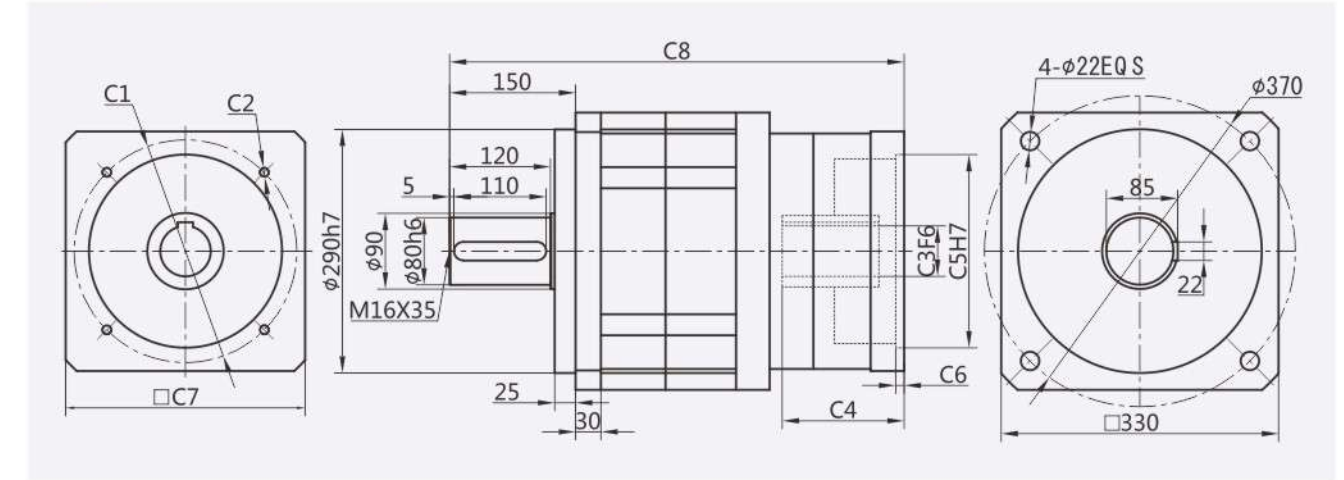

适配电机输入接口尺寸(左端为输入尺寸)

Adapter motor input interface size (The left end is the input size)

尺寸 Size	C1	C2	C3	C4	C5	C6	C7	C8
PLX-330-L1	φ265	4-M12	φ60	145	φ230	10	150	541

PLX-330-L2

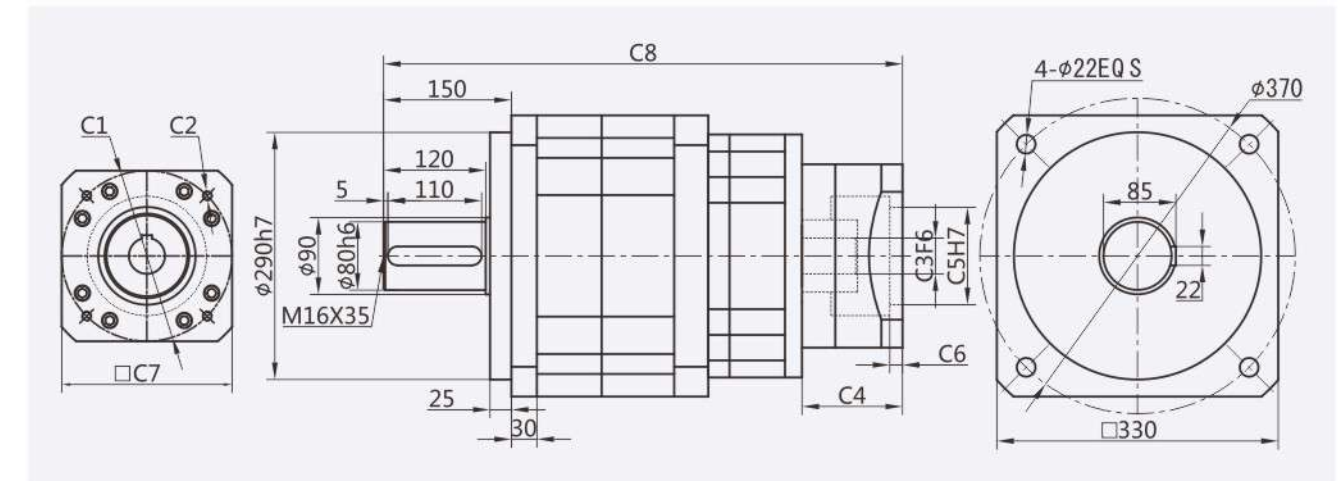

适配电机输入接口尺寸(左端为输入尺寸)

Adapter motor input interface size (The left end is the input size)

尺寸 Size	C1	C2	C3	C4	C5	C6	C7	C8
PLX-330-L2	φ200	4-M12	φ42	118	φ114.3	15	220	609
	φ235	4-M12	φ42	118	φ200	15	220	609

外形尺寸图表

Outline dimensional

PLX-330-L3

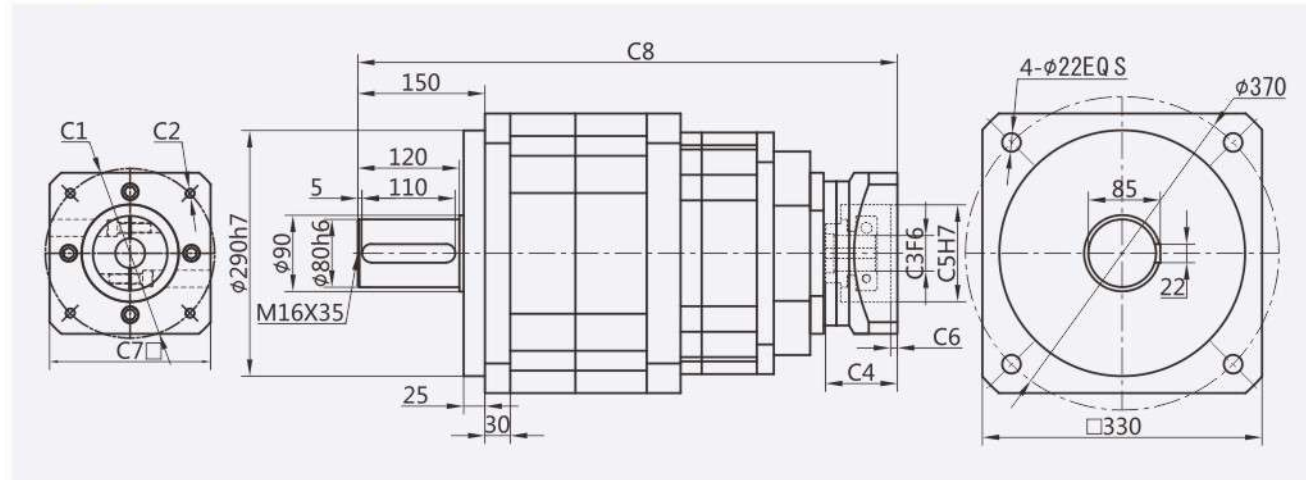

适配电机输入接口尺寸(左端为输入尺寸)

Adapter motor input interface size (The left end is the input size)

尺寸 Size	C1	C2	C3	C4	C5	C6	C7	C8
PLX-330-L3	$\phi 215$	4-M12	$\phi 38/\phi 42$	85	$\phi 180$	7	150	637
	$\phi 200$	4-M12	$\phi 35$	115	$\phi 114.3$	7	150	667
	$\phi 235$	4-M12	$\phi 38/\phi 42$	120	$\phi 200$	7	150	673
	$\phi 200$	4-M12	$\phi 35$	85	$\phi 114.3$	7	180	637

- ✓ ZPT070
- ✓ ZPT090
- ✓ ZPT110
- ✓ ZPT140

ZPT Series



ZPT系列减速机核心特性

The Core Characteristics of ZPT Series Reducer

- 1 采用直齿齿轮传动，经渗碳淬火处理，齿向齿廓修形处理，确保运行平稳，噪音小；
- 2 结构简单，可大批量生产，且交货期快性价比高；
- 3 减速机种类齐全，可以满足市场上绝大多数减速机的配合。

- 1 Adopt straight tooth gear transmission, through carburizing and quenching treatment, tooth profile modification treatment, ensure smooth operation, low noise.
- 2 Simple structure, mass production, and fast delivery time and high cost performance.
- 3 Reducer has a complete range, which can meet the needs of most reducer in the market.

减速机性能资料 Gear box performance information

型号 Model	单位 Unit	ZPT070	ZPT090	ZPT110	ZPT140	减速比 Ratio	Stage
额定输出扭矩 Rated output torque	N·m		45	80	170	1	1
		35				2	
			45	80	170	3	
			45	80	170	4	
			45	80	170	5	
			45	80	170	7	
		35				8	
		35	45	80	170	10	
			45	80	170	12	2
		35				14	1
			45	80	170	15	2
			45	80	170	16	
		35	45	80	170	20	1
			45	80	170	25	2
			45	80	170	28	
		35				32	2
			45	80	170	35	2
		35	45	80	170	40	
		35	45	80	170	50	
		35				56	
			45	80	170	70	2
			45	80	170	64	
			45	80	170	80	3
		35	45	80	170	100	
			45	80	170	125	
		35	45	80	170	140	
			45	80	170	175	
			45	80	170	200	
	45	80	170	250			
	45	80	170	280			
	45	80	170	350			
故障停滞扭矩 Emergency stop torque	N·m	2倍额定输出扭矩 2 times Rated output torque					
额定输入转速 Nominal input speed	rmp	3000	2500	2000	2000		
最大输入转速 Maximum input speed	rmp	4000	3500	3000	3000		
最大径向力 Maximum radial force	N	950	1450	2100	2700		
最大轴向力 Maximum axial force	N	425	725	1050	1350		
效率 Efficiency	%	Single [97%]		Double [95%]			
平均寿命 Average lifetime	h	20000					
重量 Weight	kg	4.2	6.8	11.6	19.8	1	
		4.6	7.4	13.8	23.9	2	
			8.0	16.0	28.0	3	

减速机性能资料 Gear box performance information

型号 Model	单位 Unit	ZPT070	ZPT090	ZPT110	ZPT140	减速比 Ratio	Stage	
转动惯量 Moment of inertia	kgcm ²		0.4	0.4	1.65	3	1	
			0.309	0.309	1.22	4		
			0.291	0.291	1.15	5		
			0.285	0.285	1.70	7		
		0.094				8		
		0.092	0.283	0.283	1.13	10		
			0.4	0.4	1.65	12		2
		0.092				14		1
			0.309	0.309	1.22	15	2	
			0.291	0.291	1.22	16		
		0.091	0.291	0.291	1.15	20	1	
			0.291	0.291	1.15	25	2	
			0.285	0.285	1.13	28		
		0.094				32	2	
			0.285	0.285	1.13	35	2	
		0.092	0.283	0.283	1.11	40		
		0.092	0.285	0.285	1.11	50		
		0.091				56		
		0.091	0.285	0.285	1.11	70	2	
			0.291	0.291	1.15	64		
		0.091	0.291	0.291	1.15	80	3	
		0.091	0.291	0.291	1.15	100		
			0.291	0.291	1.15	125		
		0.091	0.285	0.285	1.13	140		
			0.285	0.285	1.13	175		
			0.283	0.283	1.11	200		
			0.283	0.283	1.11	250		
			0.283	0.283	1.11	280		
			0.283	0.283	1.70	350		
		噪音 Noise	dB	70	70	70	70	70
		润滑 Lubricating		合成油脂润滑 Synthetic grease lubrication				
		防护等级 levels of protection		IP65				

外形尺寸图表
Outline dimensional

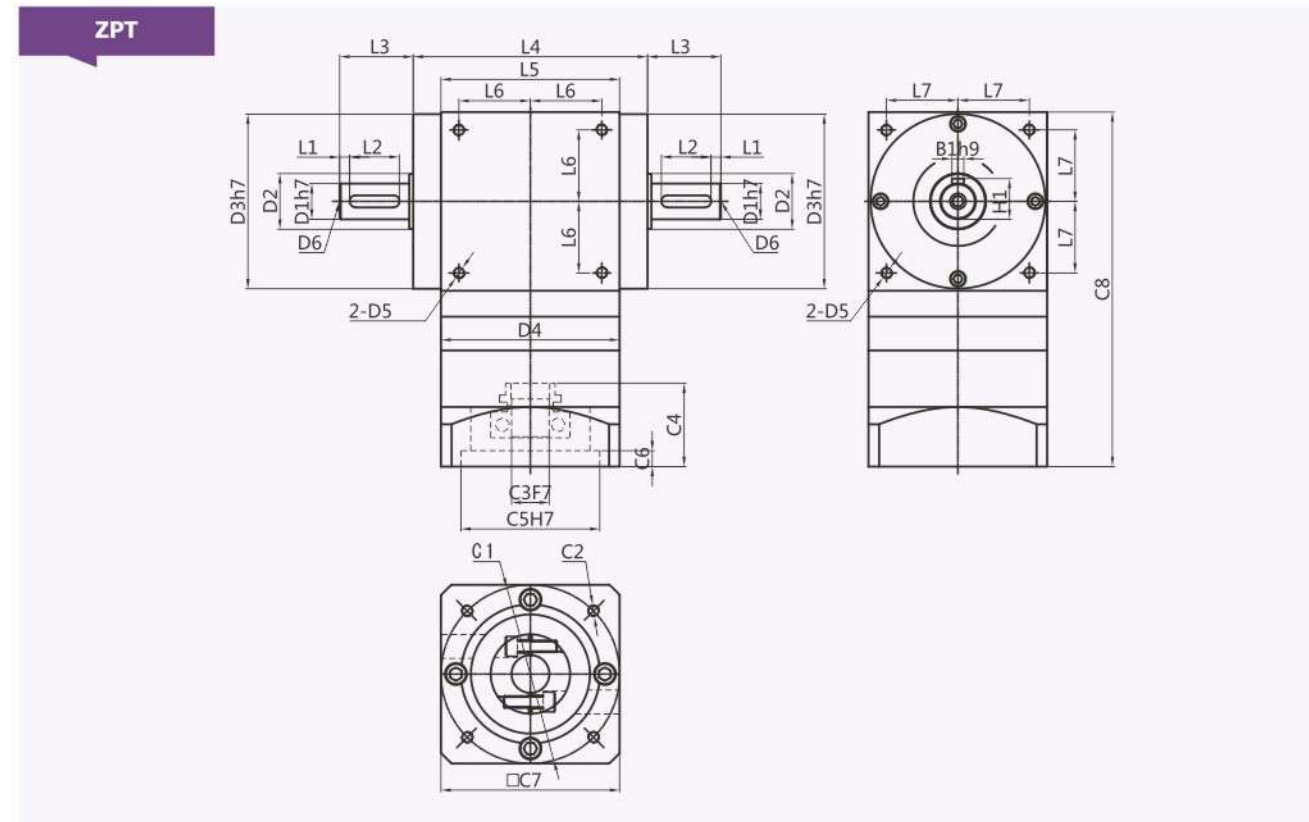

适配电机输入接口尺寸(左端为输入尺寸)
Adapter motor input interface size (The left end is the input size)

尺寸 Size	ZPT070	ZPT090	ZPT110	ZPT140	
C1	Φ70	Φ90	Φ90	Φ145	
C2	4-M4/4-M5	4-M5/4-M6	4-M5/4-M6	4-M8	
C3	Φ14	Φ19	Φ19	Φ19/Φ22/Φ24	
C4	31.5	42	42	60	
C5	Φ50	Φ70	Φ70	Φ110	
C6	5	8	8	8	
C7	60	90	90	120	
C8	Stage1	143	177.5	198.5	269
	Stage2	159	201	222	299.5
	Stage3		224	245	329.5
L1	3	5	3	5	
L2	25	25	30	40	
L3	36	37	37	52	
L4	77	118	134	170	
L5	70	90	110	140	
L6	26.5	36	44	55	
L7	21.2	36	44	55	
L8					
L9					
D1	16	18	22	32	
D2	25	28	35	45	
D3	60	88	108	135	
D5	4-M5	4-M6	4-M8	4-M10	
D6	M5X10	M6X12	M6X12	M10X20	
H1	18	20.5	24.5	35	
H2					
B1	5	6	6	10	
B2					

外形尺寸图表
Outline dimensional

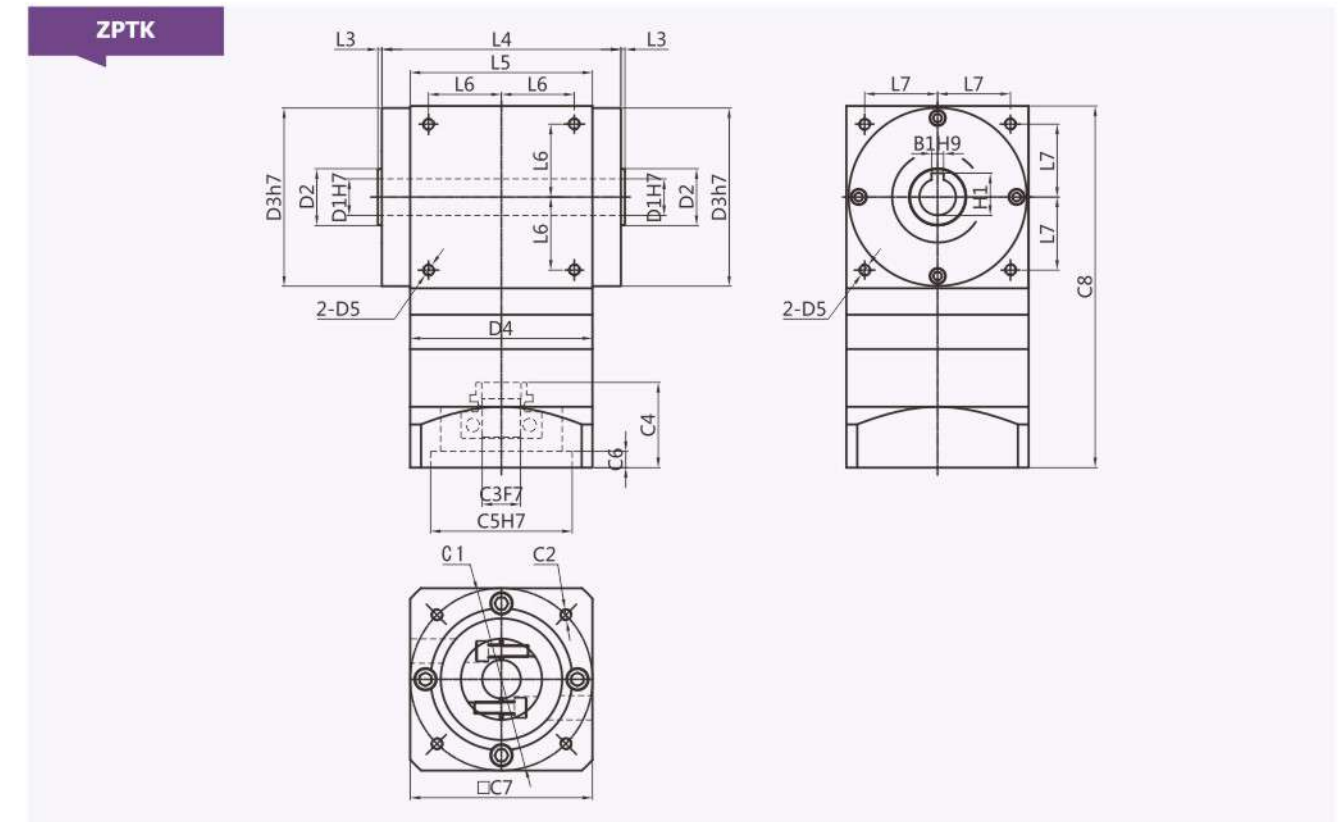

适配电机输入接口尺寸(左端为输入尺寸)
Adapter motor input interface size (The left end is the input size)

尺寸 Size	ZPTK070	ZPTK090	ZPTK110	ZPTK140	
C1	Φ70	Φ90	Φ90	Φ145	
C2	4-M4/4-M5	4-M5/4-M6	4-M5/4-M6	4-M8	
C3	Φ14	Φ19	Φ19	Φ19/Φ22/Φ24	
C4	31.5	42	42	60	
C5	Φ50	Φ70	Φ70	Φ110	
C6	5	8	8	8	
C7	60	90	90	120	
C8	Stage1	143	177.5	198.5	269
	Stage2	159	201	222	299.5
	Stage3		224	245	329.5
L1					
L2					
L3	2	2	2	2	
L4	77	118	134	170	
L5	70	90	110	140	
L6	26.5	36	44	55	
L7	21.2	36	44	55	
L8					
L9					
D1	14	18	22	28	
D2	25	28	35	45	
D3	60	88	108	135	
D5	4-M5	4-M6	4-M8	4-M10	
D6	M5X10	M6X12	M6X12	M10X20	
H1	16.3	22.8	24.8	31.3	
H2					
B1	5	6	6	8	
B2					

外形尺寸图表
Outline dimensional

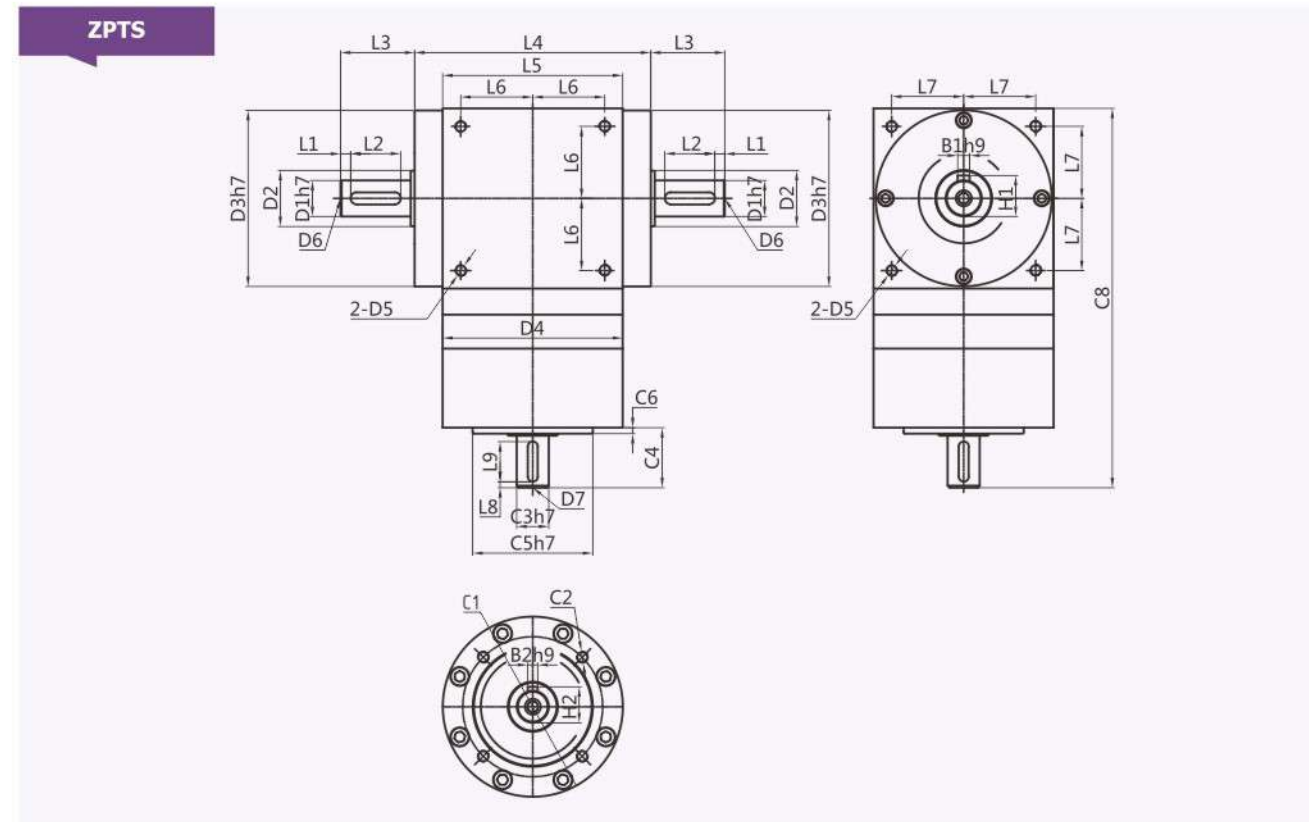

适配电机输入接口尺寸(左端为输入尺寸)
Adapter motor input interface size (The left end is the input size)

尺寸 Size	ZPTS070	ZPTS090	ZPTS110	ZPTS140
C1	Φ52	Φ70	Φ70	Φ100
C2	4-M5	4-M6	4-M6	4-M10
C3	Φ10	Φ16	Φ16	Φ20
C4	25	30	30	46
C5	Φ40	Φ60	Φ60	Φ8
C6	5	8	8	8
C7				
C8	Stage1	151.5	189.5	210
	Stage2	167.5	213	233.5
	Stage3		236	256.5
L1	3	5	3	5
L2	25	25	30	40
L3	36	37	37	52
L4	77	118	134	170
L5	70	90	110	140
L6	26.5	36	44	55
L7	21.2	36	44	55
L8	3	3	3	5
L9	15	20	20	30
D1	16	18	22	32
D2	25	28	35	45
D3	60	88	108	135
D5	4-M5	4-M6	4-M8	4-M10
D6	M5X10	M6X12	M6X12	M10X20
H1	18	20.5	24.5	35
H2	12.3	18	18	22.5
B1	5	6	6	10
B2	3	6	6	6

外形尺寸图表
Outline dimensional

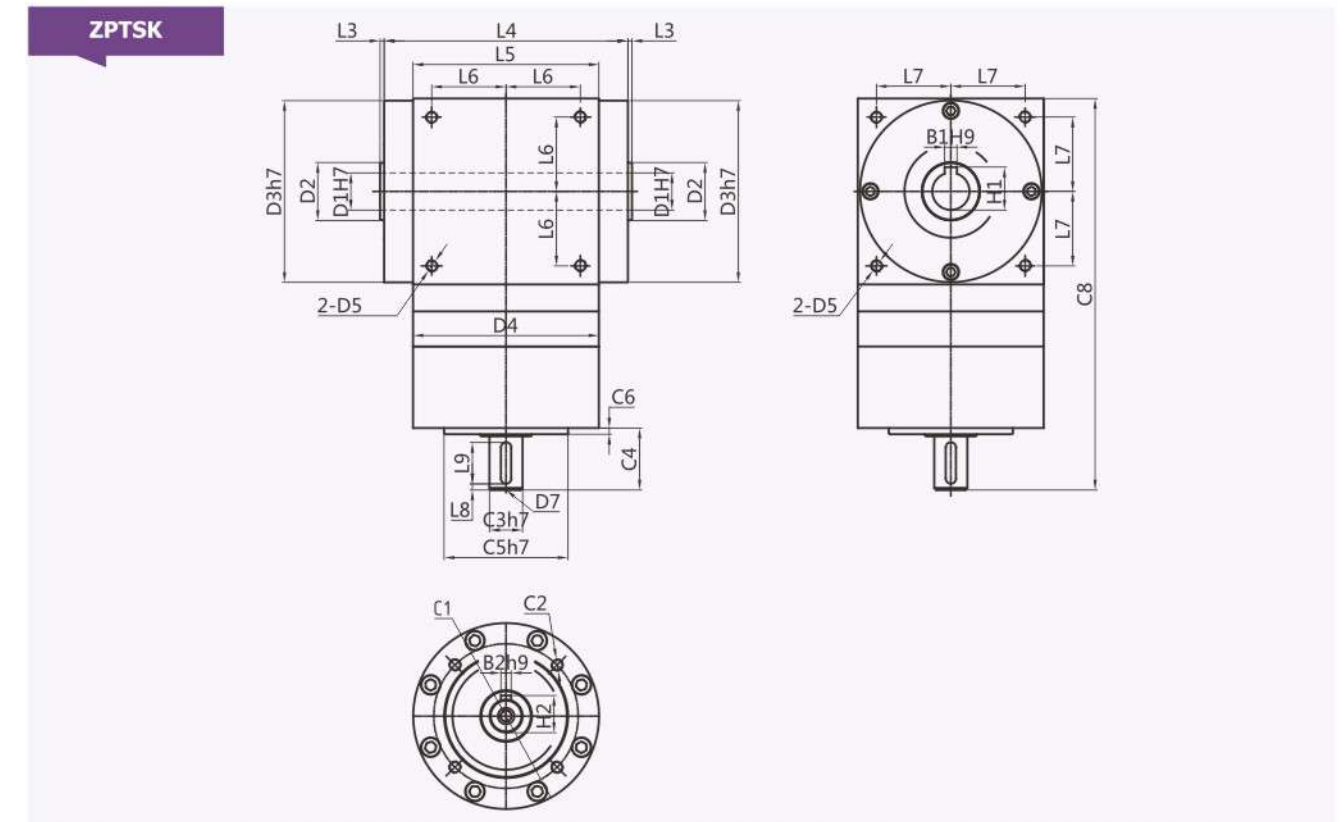

适配电机输入接口尺寸(左端为输入尺寸)
Adapter motor input interface size (The left end is the input size)

尺寸 Size	ZPTSK	ZPTSK	ZPTSK	ZPTSK
C1	Φ52	Φ70	Φ70	Φ100
C2	4-M5	4-M6	4-M6	4-M10
C3	Φ10	Φ16	Φ16	Φ20
C4	25	30	30	46
C5	Φ40	Φ60	Φ60	Φ8
C6	5	8	8	0
C7				8
C8	Stage1	151.5	189.5	210
	Stage2	167.5	213	233.5
	Stage3		236	256.5
L1				276
L2				
L3	2	2	2	2
L4	77	118	134	170
L5	70	90	110	140
L6	26.5	36	44	55
L7	21.2	36	44	55
L8	3	3	3	5
L9	15	20	20	30
D1	14	18	22	28
D2	25	28	35	45
D3	60	88	108	135
D5	4-M5	4-M6	4-M8	4-M10
D6	M5X10	M6X12	M6X12	M10X20
H1	16.3	22.8	24.8	31.3
H2	12.3	18	18	22.5
B1	5	6	6	8
B2	3	6	6	6

目录
CONTENTS



AF
Page 11



ALF
Page 18



AL
Page 21



ALE
Page 28



AXF
Page 31



AGH
Page 38



ZAF
Page 45



ZAL
Page 53



ZAGH
Page 60

Product features

产品特点

精密行星齿轮减速机是我公司自主研发的新一代实用性产品，具有以下一些主要特点

Precision planetary gear reducer is a new generation of practical products independently developed by our company, which has the following main characteristics



低噪音
Low noise
低于65db。
below 65db.



高输入转速
High input speed
可达5000RPM。
Up to 5000RPM.



低间隙
Low Backlash
单级可达3弧分内，双级可达5弧分内。
One stage within 3 arc minutes, Two stage with 5 arcmin.



高扭矩
High torque
比一般行星减速机扭矩高。
Higher than conventional planetary gearbox.



高效率
High efficiency
单段式在97%以上，双段式在95%以上。
One stage is exceed 97%, Two stage is exceed 95%.



高稳定性
High stability
采用高强度合金钢材，整个齿轮经硬化处理，非只有表面硬化，确保使用寿命及长期使用仍保持最初的精密度。
Using high-strength steel alloy material .Not just hardening on gear surface, but hardening entire gear to insure the gear life time and maintain high accuracy.

Product application

产品用途

精密行星齿轮减速机被广泛应用于以下领域

Precision planetary gear reducer is widely used in the following fields

- 01 航空航天。
Aerospace.
- 02 医疗卫生、电子信息技术产业。
Medical health care, electronic information technology industry.
- 03 工业机器人、生产自动化、数控机床制造产业。
Industrial robot, production automation, CNC machine tool manufacturing industry.
- 04 汽车制造、纺织、印刷、食品、冶金、环保工程、仓储物流等产业。
Motor, textile, printing, food, metallurgical, environmental protection engineering, warehouse and logistics industry.

Description Reducer

减速机订货说明

减速机型号说明 Reducer model description

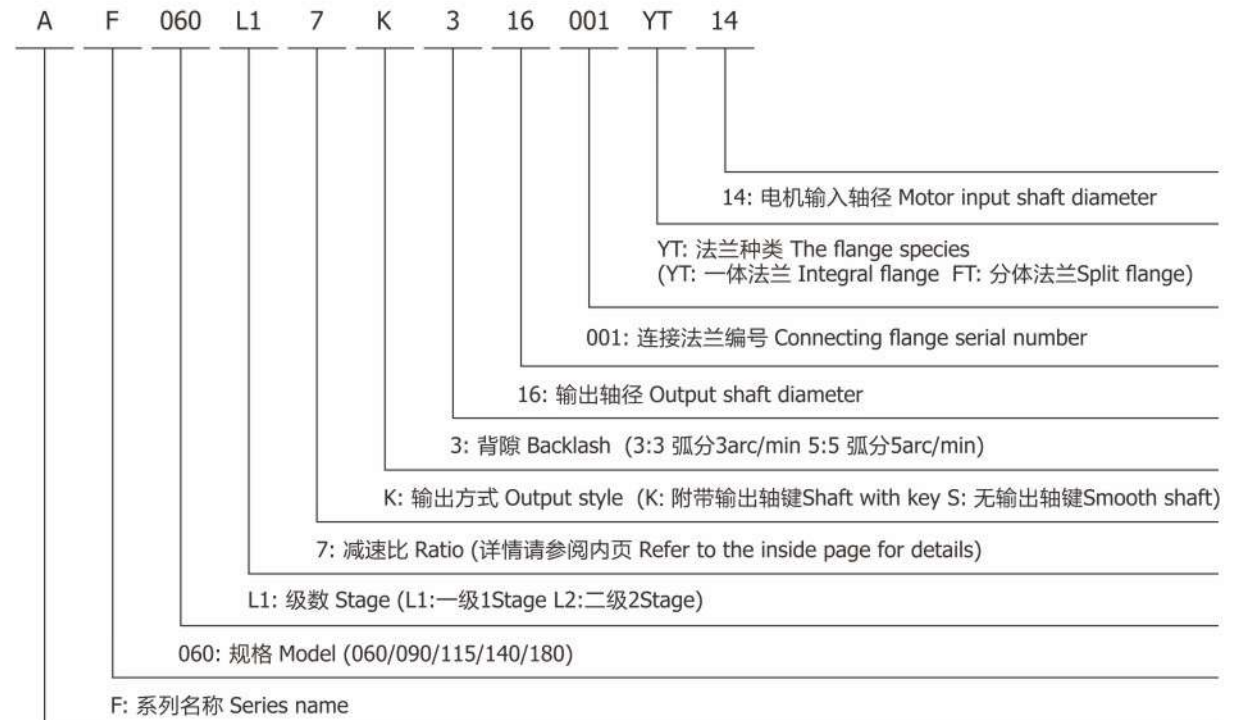

A: A减速机的名称 Model name for A reducer

电机输出安装尺寸说明 Motor output installation dimension description

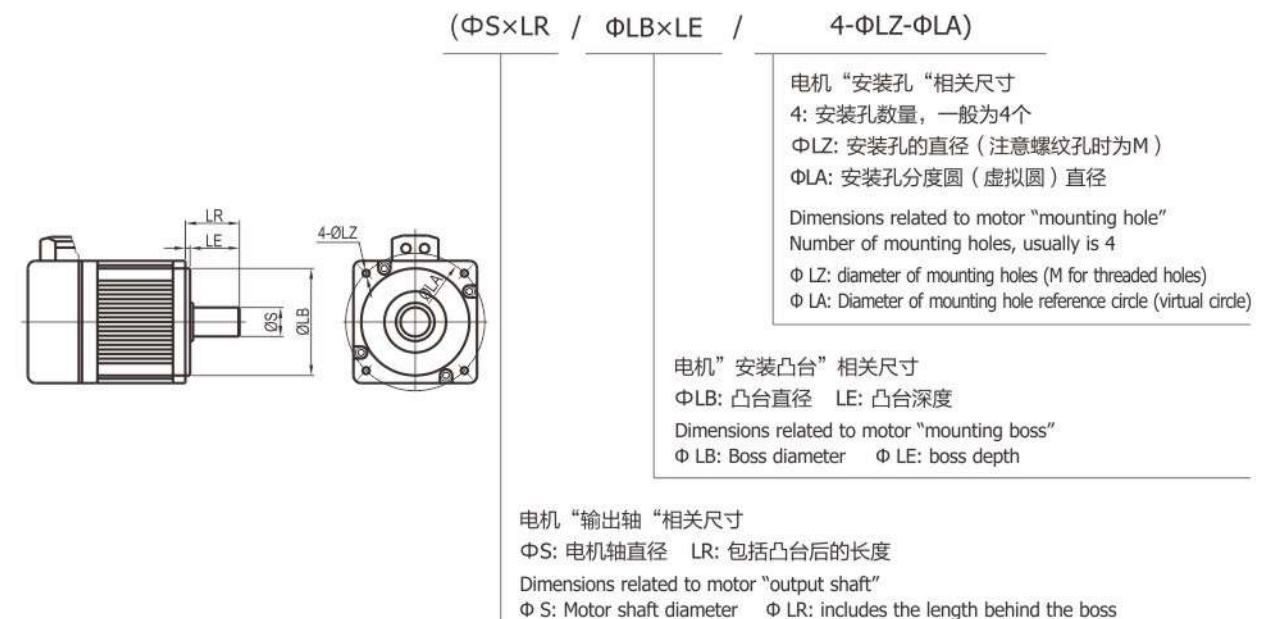

- AF060
- AF090
- AF115
- AF140
- AF180

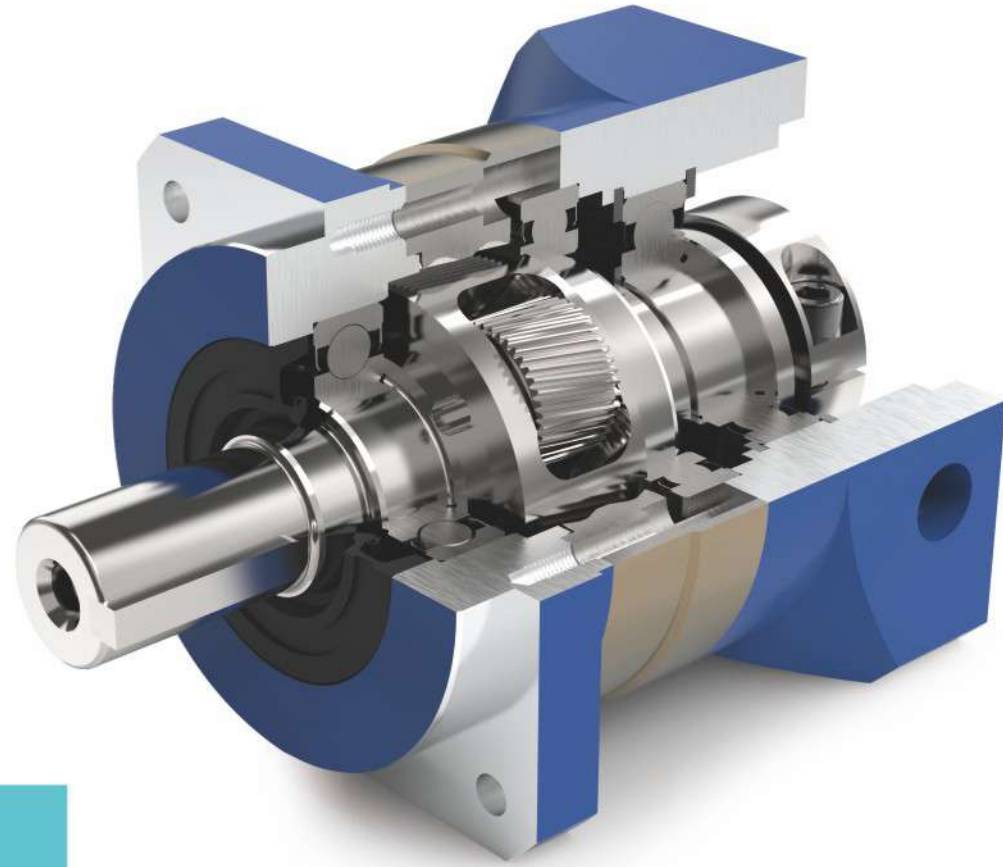

AF Series

AF系列减速机核心特性

The Core Characteristics of AF Series Reducer

- 1 采用斜齿齿轮传动，经渗碳淬火处理，齿向齿廓修形处理，确保运行低噪音、平稳，承载能力较直齿提高20%；
- 2 整体式输出轴，行星轮两端轴承支撑，实现高精度、强度；
- 3 回程间隙小，精密型单级可以做到3arcmin以内。

- 1 Helical gear transmission, carburizing and quenching treatment, tooth profile modification treatment, to ensure low noise and smooth operation. The bearing capacity is 20% higher than that of straight teeth.
- 2 Integral output shaft and bearing support at both ends of planetary wheel to achieve high precision and strength.
- 3 The backlash clearance is small, and the precision single stage can achieve less than 3 arcmin.

减速机性能资料 Gear box performance information

型号 Model	单位 Unit	AF060	AF090	AF115	AF140	AF180	减速比 Ratio	Stage			
额定输出扭矩 Rated output torque	N·m	35	100	230	450	1000	3	1			
		45	110	270	580	1300	4				
		44	105	255	540	1100	5				
		40	100	180	390	800	7				
		22	50	120	230	460	10				
		35	100	230	450	1000	15				
		45	110	270	580	1300	16	2			
		45	110	270	580	1300	20				
		44	105	255	540	1100	25				
		45	110	270	580	1300	28				
		35	100	230	450	1000	30				
		44	105	255	540	1100	35				
		45	110	270	580	1300	40				
		44	105	255	540	1100	50				
		40	100	180	390	800	70				
		22	50	120	230	460	100				
		故障停滞扭矩 Emergency stop torque	N·m	3倍额定输出扭矩 3 times Rated output torque							
		额定输入转速 Norminal input speed	rpm	3000	3000	3000	2000		1500		
额定输入转速 Maximum input speed	rpm	6000	6000	6000	4000	3000					
最大径向力 ¹⁾ Maximum radial force	N	920	1400	3000	5800	9500					
最大轴向力 ¹⁾ Maximum axial force	N	630	600	2500	4500	6800					
效率 Efficiency	%	Single [97%]			Double [95%]						
平均寿命 Average lifetime	h	20000									
重量 (大概) Weight	kg	1.1	3.0	6.8	17	31.5		1			
		1.6	4.3	10	24	37.5		2			
转动惯量 Moment of inertia	kgcm ²	0.22	1.2	3.3	20	44	3	1			
		0.17	0.95	2	15	28	4				
		0.16	0.86	1.6	14	22	5				
		0.14	0.79	1.1	12	16	7				
		0.14	0.75	0.95	11	14	10				
		0.14	0.72	0.8	11	12	15				
		0.14	0.5	0.9	11	13	16	2			
		0.13	0.44	0.8	11	12	20				
		0.13	0.44	0.8	11	12	25				
		0.14	0.39	0.8	11	13	28				
		0.13	0.39	0.7	10	11	30				
		0.13	0.39	0.8	11	12	35				
		0.13	0.39	0.7	10	11	40				
		0.13	0.39	0.7	10	11	50				
		0.13	0.39	0.7	10	11	70				
		0.13	0.39	0.7	10	11	100				
		回程间隙 Backlash	arcmin	≤ 3	≤ 3	≤ 3	≤ 5		≤ 5		Precise[1]
				≤ 5	≤ 5	≤ 5	≤ 7		≤ 7		Standard[1]
≤ 5	≤ 5			≤ 5	≤ 7	≤ 7		Precise[2]			
≤ 7	≤ 7			≤ 7	≤ 10	≤ 10		Standard[2]			
抗扭刚性 Torsional rigidity	N·m/arc min	7	14	25	50	145					
噪音 Noise	dB	60	62	62	68	70					
润滑 lubricating		合成油脂润滑 Synthetic grease lubrication									
防护等级 levels of protection		IP65									

※1 输出转速为100rpm时，作用于输出轴中心位置

外形尺寸图表
Outline dimensional

AF060-L1[Single]

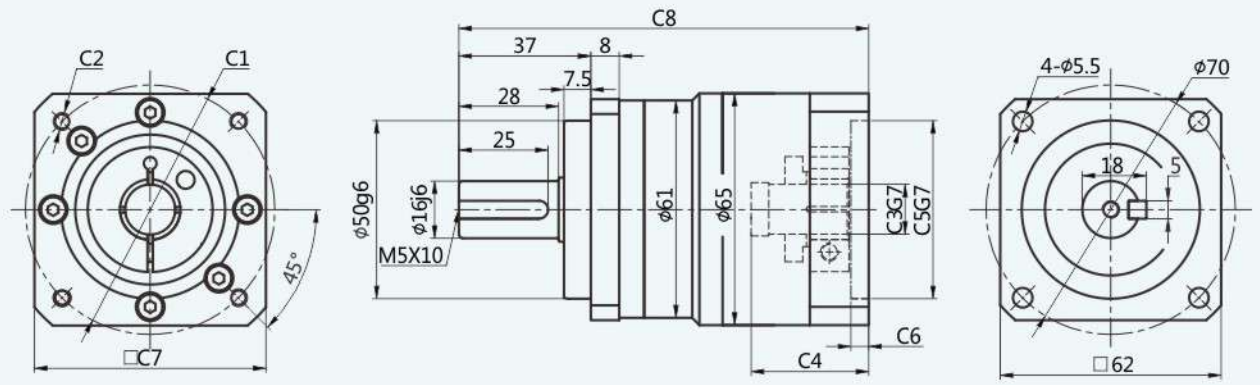

AF060-L2[Double]

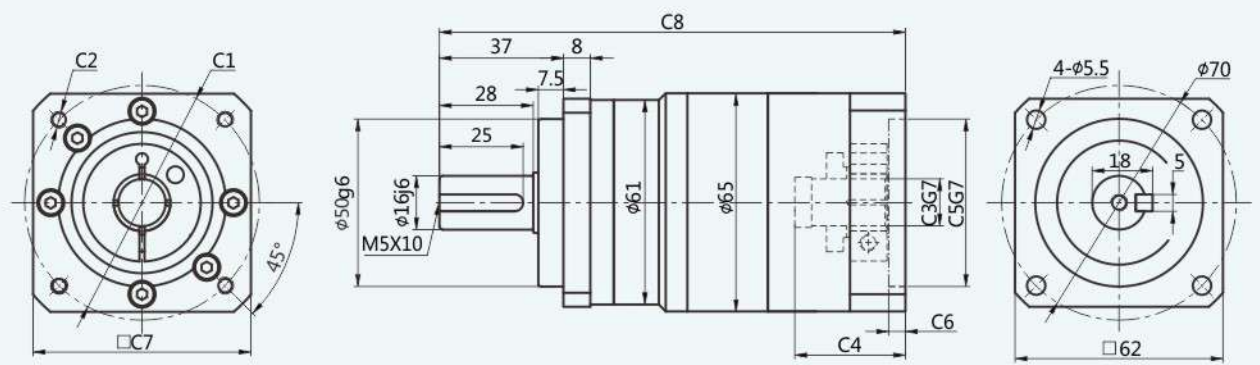

适配电机输入接口尺寸(左端为输入尺寸)
Adapter motor input interface size (The left end is the input size)

尺寸 Size	C1	C2	C3	C4	C5	C6	C7	C8
AF-060-L1	□47.14	4-M4	φ8	30	φ38.1	5	65	112
	φ46	4-M4	φ8	30	φ30	5	65	112
	φ45	4-M3	φ8	30	φ30	5	65	112
	φ70	4-M4/4-M5	φ14	33	φ50	5	65	115
AF-060-L2	□47.14	4-M4	φ8	30	φ38.1	5	65	136
	φ46	4-M4	φ8	30	φ30	5	65	136
	φ45	4-M3	φ8	30	φ30	5	65	136
	φ70	4-M4/4-M5	φ14	33	φ50	5	65	139

外形尺寸图表
Outline dimensional

AF090-L1[Single]

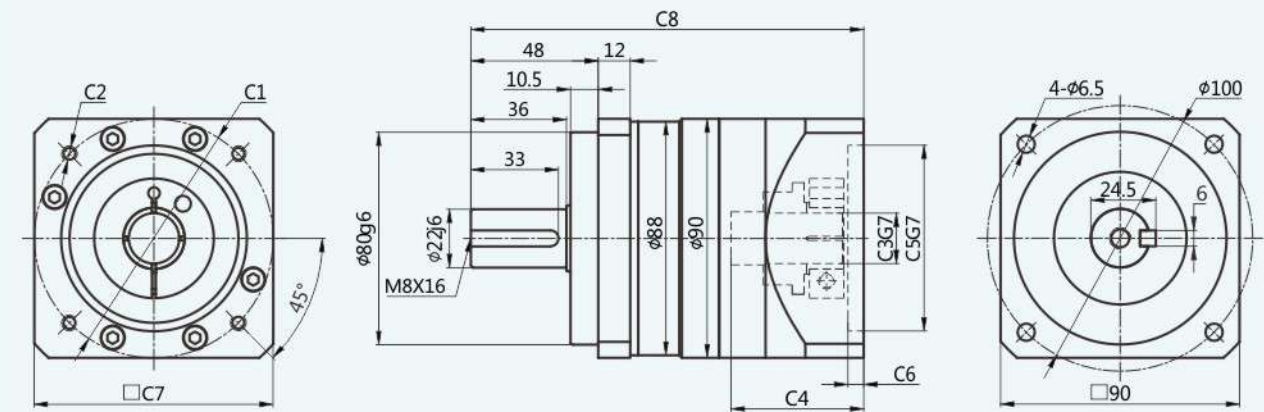

AF090-L2[Double]

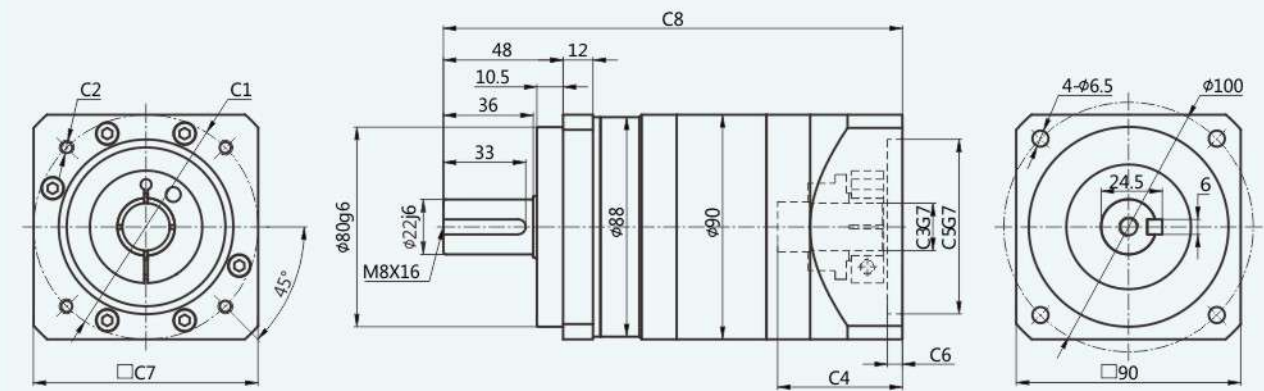

适配电机输入接口尺寸(左端为输入尺寸)
Adapter motor input interface size (The left end is the input size)

尺寸 Size	C1	C2	C3	C4	C5	C6	C7	C8
AF-090-L1	φ98.4	4-M6/4-M5	φ14/φ19	50	φ73	6	90	148
	φ90	4-M5/4-M6	φ19	50	φ70	6	90	148
	φ115	4-M8	φ19/φ22	62	φ95	8	110	160
	φ130	4-M8	φ19/φ22	62	φ95	8	110	160
	φ145	4-M8	φ19/φ22/φ24	65.5	φ110	14	130	163.5
AF-090-L2	φ70	4-M4/4-M5	φ14	38.5	φ50	5	65	175
	φ98.4	4-M6/4-M5	φ14/φ19	50	φ73	6	90	184
	φ90	4-M5/4-M6	φ19	50	φ70	6	90	184
	φ115	4-M8	φ19/φ22	62	φ95	8	110	196
	φ130	4-M8	φ19/φ22	62	φ95	8	110	196
φ145	4-M8	φ19/φ22	65.5	φ110	14	130	199.5	

外形尺寸图表
Outline dimensional

AF115-L1[Single]

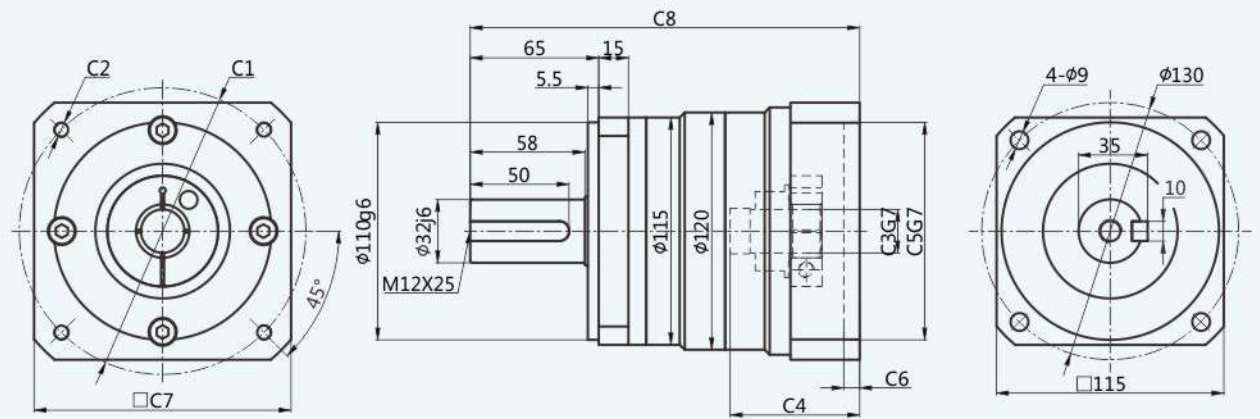

AF115-L2[Double]

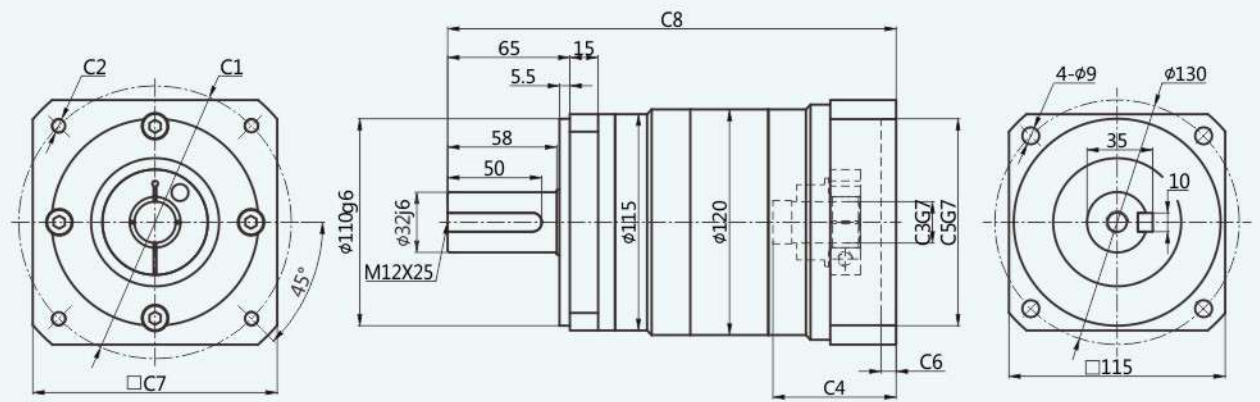

适配电机输入接口尺寸(左端为输入尺寸)
Adapter motor input interface size (The left end is the input size)

尺寸 Size	C1	C2	C3	C4	C5	C6	C7	C8
AF-115-L1	φ115	4-M8/4-M6	φ19/φ22/φ24	62.5	φ95	8	130	194
	φ130	4-M8	φ19/φ22/φ24	62.5	φ95	8	130	194
	φ145	4-M8	φ19/φ22/φ24	65.5	φ110	8	130	197
AF-115-L2	φ90	4-M5/4-M6	φ19	57.5	φ70	6	130	230.5
	φ115	4-M8/4-M6	φ19/φ22/φ24	62.5	φ95	8	130	235.5
	φ130	4-M8	φ19/φ22/φ24	62.5	φ95	8	130	235.5
	φ145	4-M8	φ19/φ22/φ24	65.5	φ110	8	130	238.5

外形尺寸图表
Outline dimensional

AF140-L1[Single]

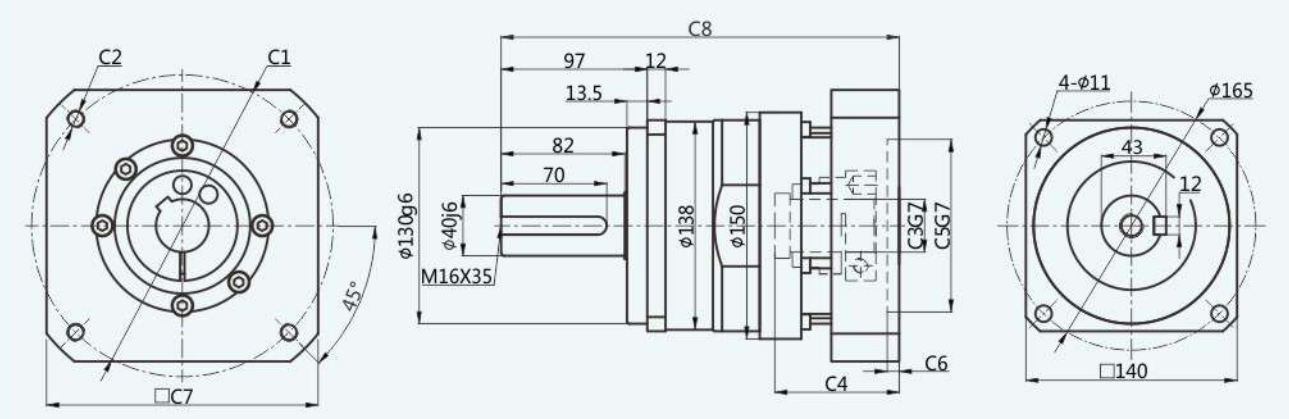

AF140-L2[Double]

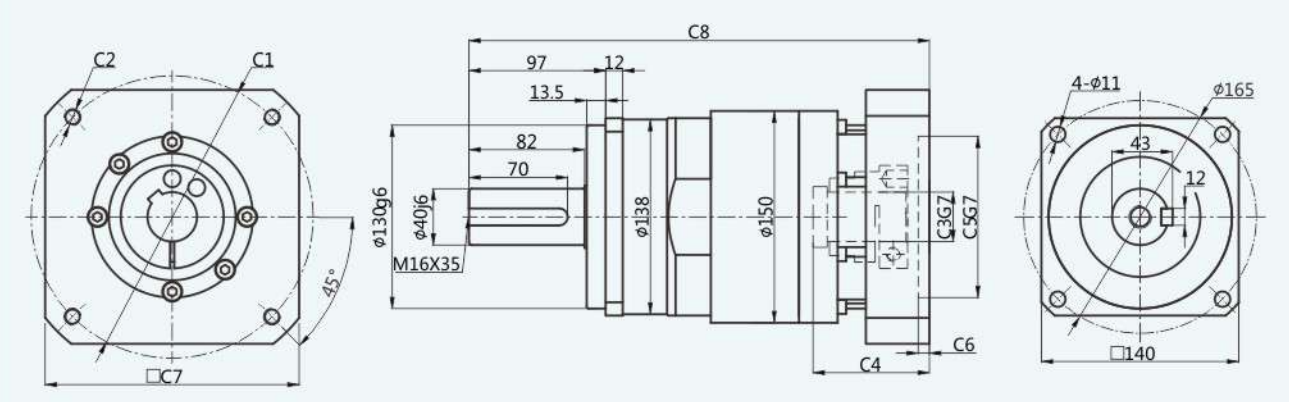

适配电机输入接口尺寸(左端为输入尺寸)
Adapter motor input interface size (The left end is the input size)

尺寸 Size	C1	C2	C3	C4	C5	C6	C7	C8
AF-140-L1	φ115	4-M8/M6	φ22/φ24	67.5	φ95	8	115	249
	φ145	4-M8	φ22/φ24	72.5	φ110	8	130	254
	φ200	4-M12	φ35/φ38/φ42	82.5	φ114.3	8	180	264
	φ200	4-M12	φ35/φ42	117	φ114.3	8	180	296.5
	φ215	4-M12	φ38/φ42	87.5	φ180	8	200	269
AF-140-L2	φ115	4-M8/M6	φ22/φ24	67.5	φ95	8	115	311.5
	φ145	4-M8	φ22/φ24	72.5	φ110	8	130	316.5
	φ200	4-M12	φ35	82.5	φ114.3	8	180	326.5

外形尺寸图表 Outline dimensional

AF180-L1[Single]

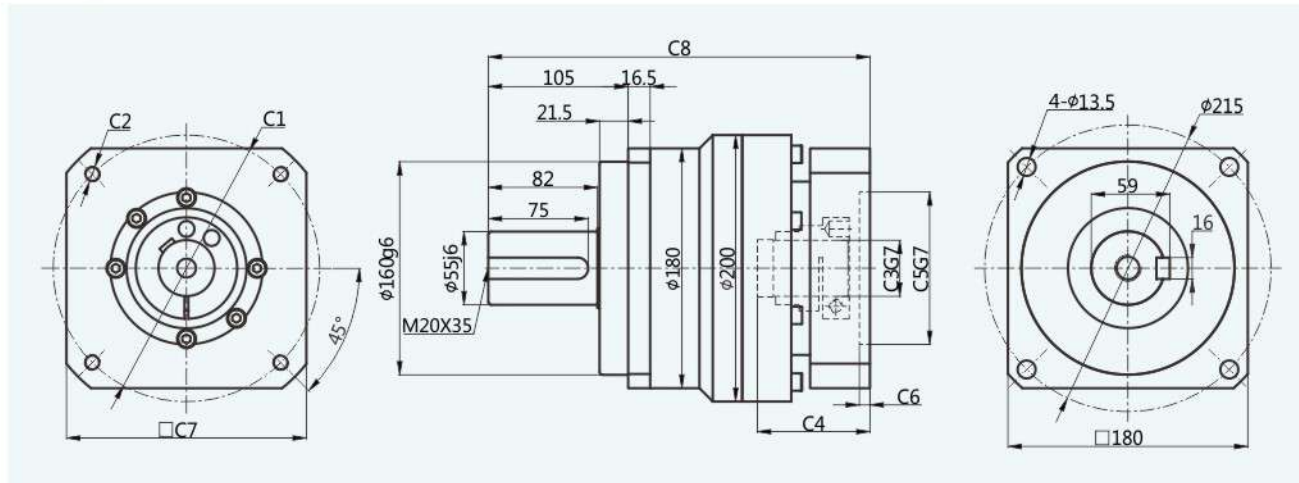

AF180-L2[Double]

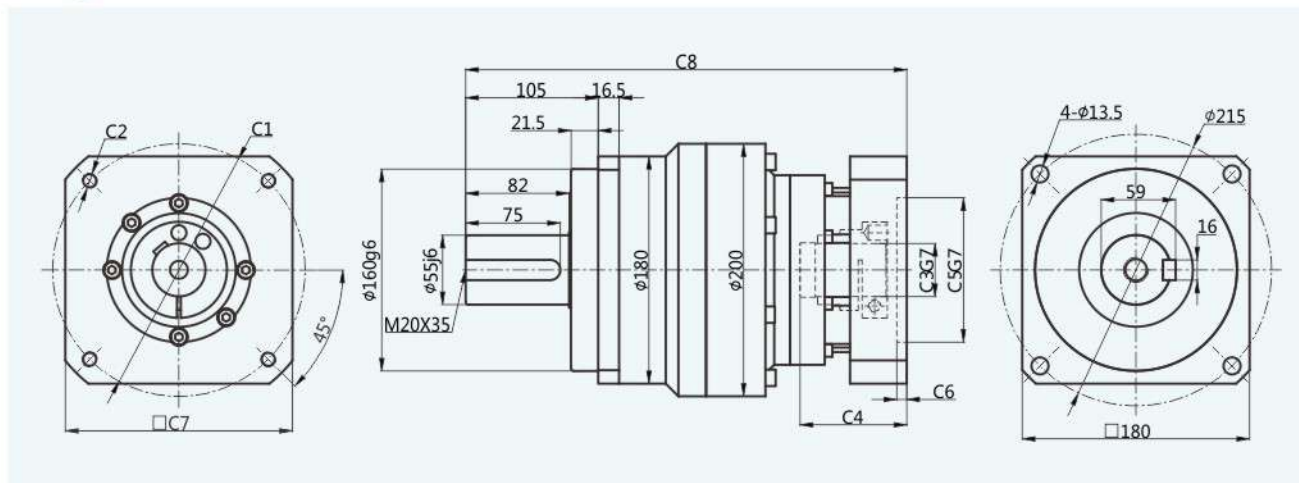

适配电机输入接口尺寸(左端为输入尺寸)
Adapter motor input interface size (The left end is the input size)

尺寸 Size	C1	C2	C3	C4	C5	C6	C7	C8
AF-180-L1	φ200	4-M12	φ35/φ38/φ42	82.5	φ114.3	8	180	286.5
	φ200	4-M12	φ35/φ42	117	φ114.3	8	180	319
	φ215	4-M12	φ38/φ42	87.5	φ180	8	200	291.5
AF-180-L2	φ115	4-M8/M6	φ22/φ24	67.5	φ95	8	115	334.5
	φ145	4-M8	φ22/φ24	72.5	φ110	8	130	339.5
	φ200	4-M12	φ35/φ38/φ42	82.5	φ114.3	8	180	349.5
	φ200	4-M12	φ35/φ42	117	φ114.3	8	180	382
	φ215	4-M12	φ38/φ42	87.5	φ180	8	200	354.5

- ALF060
- ALF090



ALF Series

ALF系列减速机核心特性

The Core Characteristics of ALF Series Reducer

- 1 采用斜齿齿轮传动，经渗碳淬火处理，齿向齿廓修形处理，确保运行低噪音、平稳，承载能力较直齿提高20%；
- 2 整体式输出轴，行星轮两端轴承支撑，实现高精度、强度；
- 3 回程间隙小，精密型单级可以做到5arcmin以内。

- 1 Helical gear transmission, carburizing and quenching treatment, tooth profile modification treatment, to ensure low noise and smooth operation. The bearing capacity is 20% higher than that of straight teeth.
- 2 Integral output shaft and bearing support at both ends of planetary wheel to achieve high precision and strength.
- 3 The backlash clearance is small, and the precision single stage can achieve less than 5 arcmin.

减速机性能资料 Gear box performance information

型号 Model	单位 Unit	ALF060	ALF090	减速比 Ratio	Stage
额定输出扭矩 Rated output torque	N·m	35	100	3	1
		45	110	4	
		44	105	5	
		40	100	7	
		22	50	10	
故障停滞扭矩 Emergency stop torque	N·m	3倍额定输出扭矩 3 times Rated output torque			
额定输入转速 Nominal input speed	rpm	3000	3000		
额定输入转速 Maximum input speed	rpm	6000	6000		
最大径向力 ^{※1} Maximum radial force	N	920	1400		
最大轴向力 ^{※1} Maximum axial force	N	630	600		
效率 Efficiency	%	Single [97%]			
平均寿命 Average lifetime	h	2000			
重量 (大概) Weight	kg	1.1	3.0		1
转动惯量 Moment of inertia	kgcm ²	0.22	1.2	3	1
		0.17	0.95	4	
		0.16	0.86	5	
		0.14	0.79	7	
		0.14	0.75	10	
回程间隙 Backlash	arcmin	≤ 5	≤ 5	Standard[1]	
抗扭刚性 Torsional rigidity	N·m/arc min	7	14		
噪音 Noise	dB	60	62		
润滑 lubricating		合成油脂润滑 Synthetic grease lubrication			
防护等级 levels of protection		IP65			

※1 输出转速为100rpm时，作用于输出轴中心位置

外形尺寸图表 Outline dimensional

ALF-060-L1[Single]

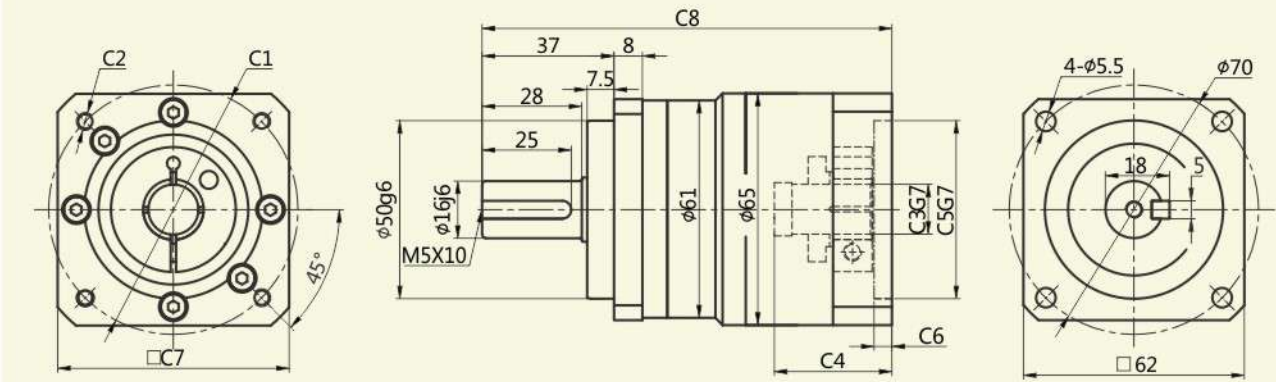

ALF-090-L1[Single]

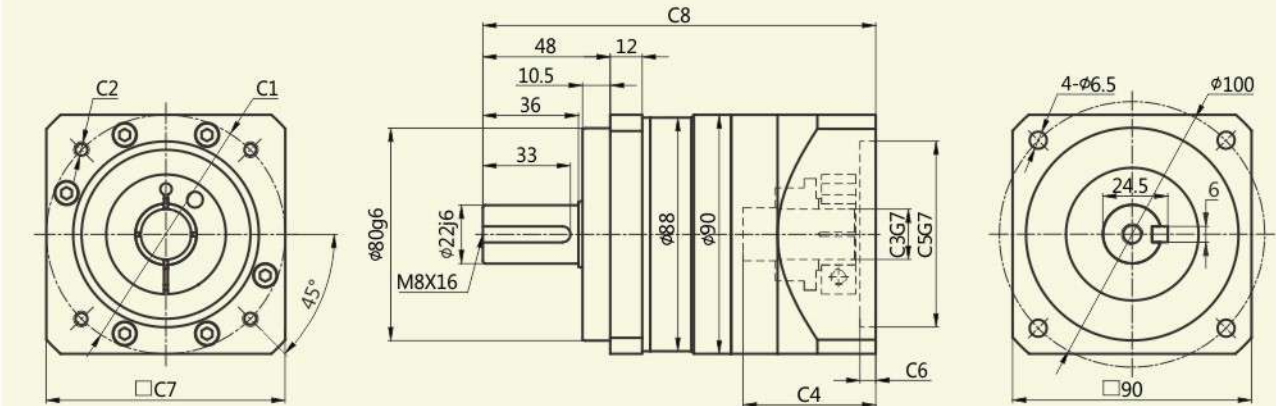

适配电机输入接口尺寸(左端为输入尺寸)
Adapter motor input interface size (The left end is the input size)

尺寸 Size	C1	C2	C3	C4	C5	C6	C7	C8
ALF-060-L1	φ70	4-M4/4-M5	φ14	33	φ50	5	65	115
ALF-090-L1	φ90	4-M5/4-M6	φ19	50	φ70	6	90	148
	φ145	4-M8	φ19/φ22/φ24	65.5	φ110	14	130	163.5

- AL070
- AL090
- AL120
- AL155
- AL205

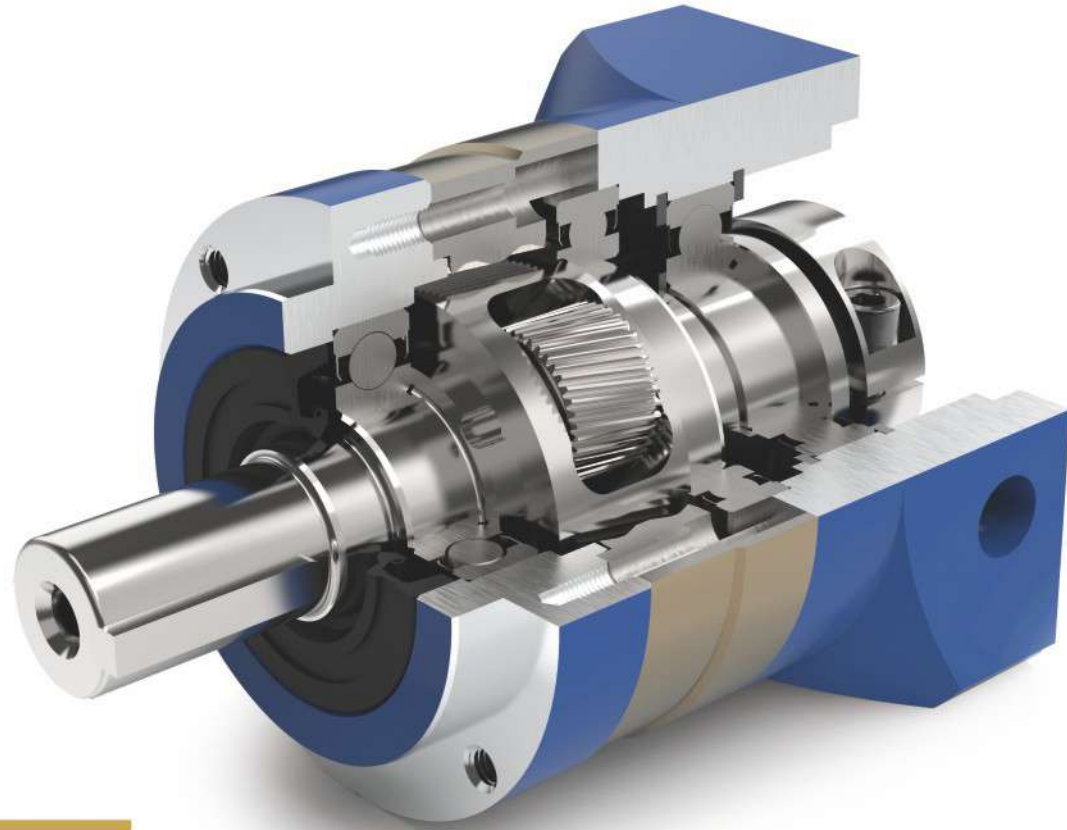

AL

Series

AL系列减速机核心特性

The Core Characteristics of AL Series Reducer

- 1 采用斜齿齿轮传动，经渗碳淬火处理，齿向齿廓修形处理，确保运行低噪音、平稳，承载能力较直齿提高20%；
- 2 整体式输出轴，行星轮两端轴承支撑，实现高精度、强度；
- 3 回程间隙小，精密型单级可以做到3arcmin以内。

- 1 Helical gear transmission, carburizing and quenching treatment, tooth profile modification treatment, to ensure low noise and smooth operation. The bearing capacity is 20% higher than that of straight teeth.
- 2 Integral output shaft and bearing support at both ends of planetary wheel to achieve high precision and strength.
- 3 The backlash clearance is small, and the precision single stage can achieve less than 3 arcmin.

减速机性能资料

Gear box performance information

型号 Model	单位 Unit	AL070	AL090	AL120	AL155	AL205	减速比 Ratio	Stage		
额定输出扭矩 Rated output torque	N·m	35	100	230	450	1000	3	1		
		45	110	270	580	1300	4			
		44	105	255	540	1100	5			
		40	100	180	390	800	7			
		22	50	120	230	460	10			
		35	100	230	450	1000	15			
		45	110	270	580	1300	16	2		
		45	110	270	580	1300	20			
		44	105	255	540	1100	25			
		45	110	270	580	1300	28			
		35	100	230	450	1000	30			
		44	105	255	540	1100	35			
		45	110	270	580	1300	40			
		44	105	255	540	1100	50			
40	100	180	390	800	70					
22	50	120	230	460	100					
故障停滞扭矩 Emergency stop torque	N·m	3倍额定输出扭矩 3 times Rated output torque								
额定输入转速 Norminal input speed	rpm	3000	3000	3000	2000	1500				
额定输入转速 Maximum input speed	rpm	6000	6000	6000	4000	3000				
最大径向力 ¹⁾ Maximum radial force	N	920	1400	3000	5800	9500				
最大轴向力 ¹⁾ Maximum axial force	N	630	600	2500	4500	6800				
效率 Efficiency	%	Single [97%]			Double [95%]					
平均寿命 Average lifetime	h	20000								
重量 (大概) Weight	kg	1.1	3.0	6.8	17	31.5		1		
		1.6	4.3	10	24	37.5		2		
转动惯量 Moment of inertia	kgcm ²	0.22	1.2	3.3	20	44	3	1		
		0.17	0.95	2	15	28	4			
		0.16	0.86	1.6	14	22	5			
		0.14	0.79	1.1	12	16	7			
		0.14	0.75	0.95	11	14	10			
		0.14	0.72	0.8	11	12	15			
		0.14	0.5	0.9	11	13	16	2		
		0.13	0.44	0.8	11	12	20			
		0.13	0.44	0.8	11	12	25			
		0.14	0.39	0.8	11	13	28			
		0.13	0.39	0.7	10	11	30			
		0.13	0.39	0.8	11	12	35			
		0.13	0.39	0.7	10	11	40			
		0.13	0.39	0.7	10	11	50			
		0.13	0.39	0.7	10	11	70			
		0.13	0.39	0.7	10	11	100			
		回程间隙 Backlash	arcmin	≤ 3	≤ 3	≤ 3	≤ 5		≤ 5	Precise[1]
				≤ 5	≤ 5	≤ 5	≤ 7		≤ 7	Standard[1]
≤ 5	≤ 5			≤ 5	≤ 7	≤ 7	Precise[2]			
≤ 7	≤ 7			≤ 7	≤ 10	≤ 10	Standard[2]			
抗扭刚性 Torsional rigidity	N·m/arc min	7	14	25	50	145				
噪音 Noise	dB	60	62	62	68	70				
润滑 lubricating		合成油脂润滑 Synthetic grease lubrication								
防护等级 levels of protection		IP65								

※1 输出转速为100rpm时，作用于输出轴中心位置

外形尺寸图表
Outline dimensional

AL070-L1[Single]

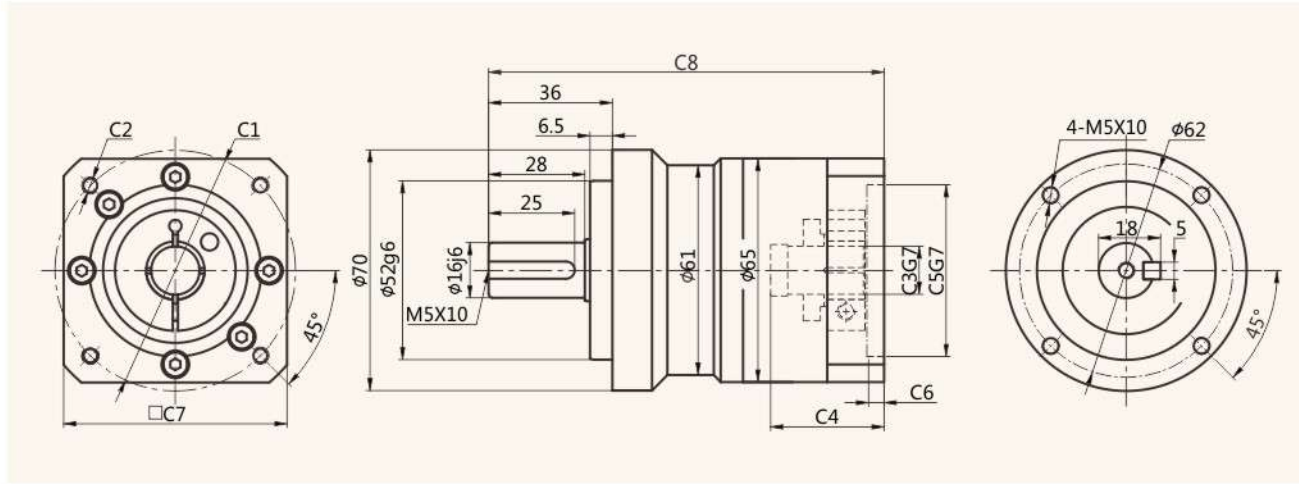

AL070-L2[Double]

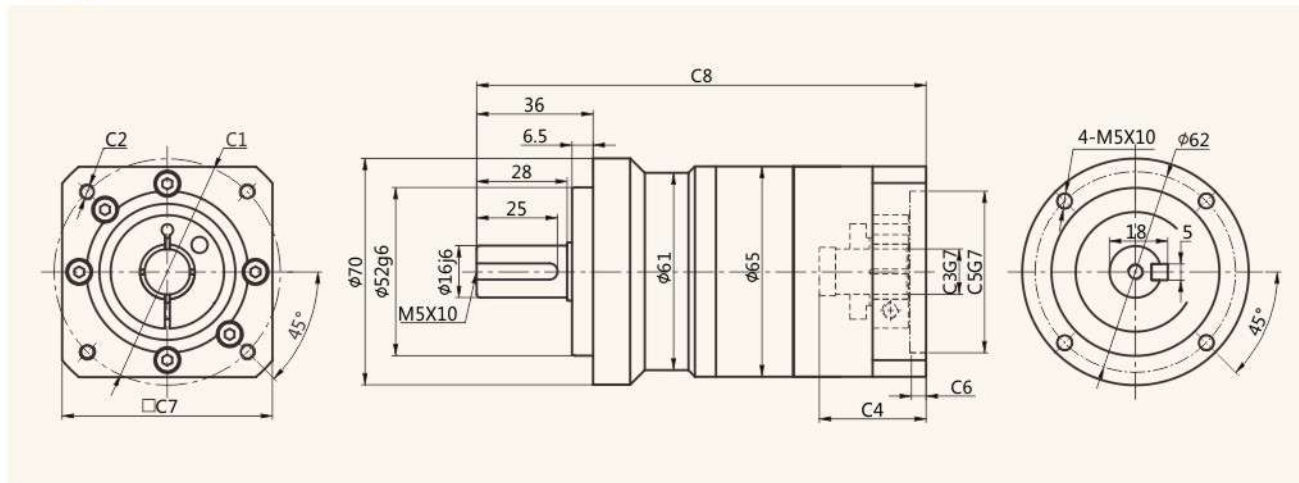

适配电机输入接口尺寸(左端为输入尺寸)
Adapter motor input interface size (The left end is the input size)

尺寸 Size	C1	C2	C3	C4	C5	C6	C7	C8
AL-070-L1	□47.14	4-M4	Φ8	30	Φ38.1	5	65	112
	Φ46	4-M4	Φ8	30	Φ30	5	65	112
	Φ45	4-M3	Φ8	30	Φ30	5	65	112
	Φ70	4-M4/4-M5	Φ14	33	Φ50	5	65	115
AL-070-L2	□47.14	4-M4	Φ8	30	Φ38.1	5	65	136
	Φ46	4-M4	Φ8	30	Φ30	5	65	136
	Φ45	4-M3	Φ8	30	Φ30	5	65	136
	Φ70	4-M4/4-M5	Φ14	33	Φ50	5	65	139

外形尺寸图表
Outline dimensional

AL090-L1[Single]

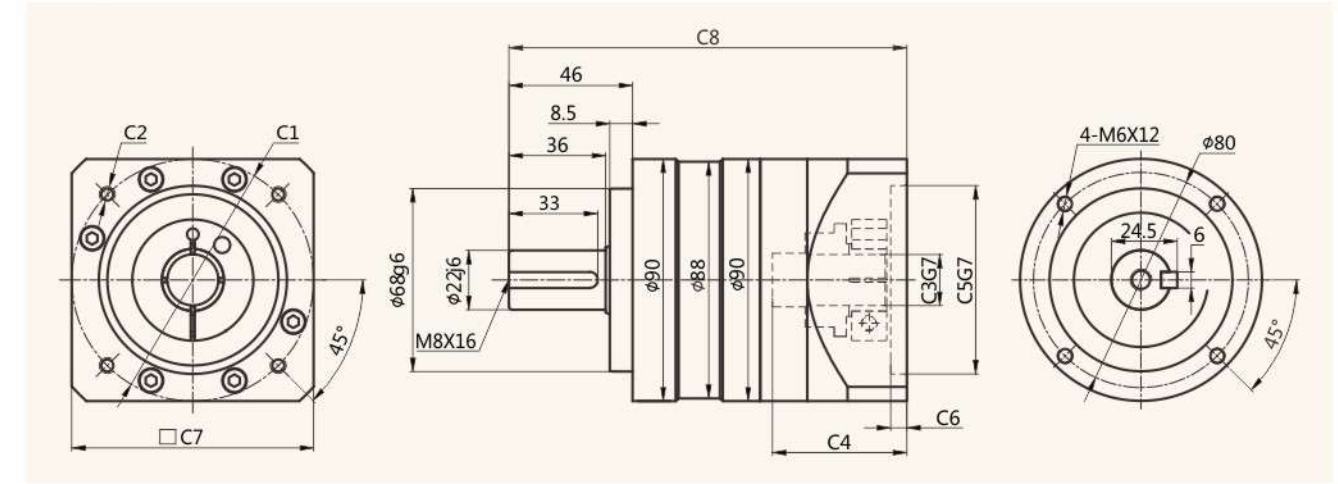

AL090-L2[Double]

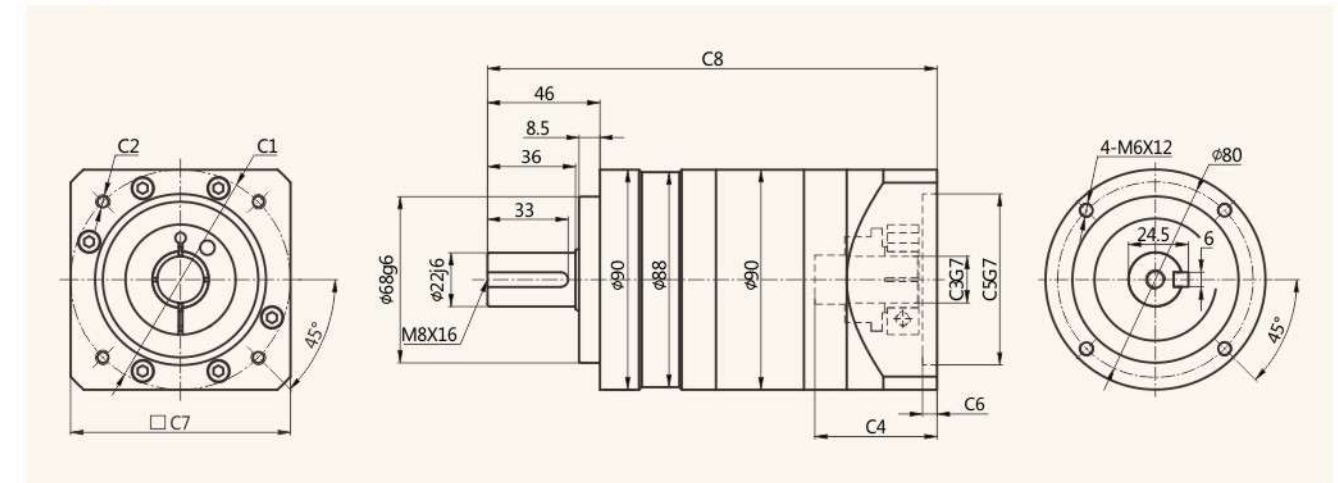

适配电机输入接口尺寸(左端为输入尺寸)
Adapter motor input interface size (The left end is the input size)

尺寸 Size	C1	C2	C3	C4	C5	C6	C7	C8
AL-090-L1	Φ98.4	4-M6/4-M5	Φ14/Φ19	50	Φ73	6	90	148
	Φ90	4-M5/4-M6	Φ19	50	Φ70	6	90	148
	Φ115	4-M8	Φ19/Φ22	62	Φ95	8	110	160
	Φ130	4-M8	Φ19/Φ22	62	Φ95	8	110	160
	Φ145	4-M8	Φ19/Φ22/Φ24	65.5	Φ110	14	130	163.5
AL-090-L2	Φ70	4-M4/4-M5	Φ14	38.5	Φ50	5	65	175
	Φ98.4	4-M6/4-M5	Φ14/Φ19	50	Φ73	6	90	184
	Φ90	4-M5/4-M6	Φ19	50	Φ70	6	90	184
	Φ115	4-M8	Φ19/Φ22	62	Φ95	8	110	196
	Φ130	4-M8	Φ19/Φ22	62	Φ95	8	110	196
Φ145	4-M8	Φ19/Φ22	65.5	Φ110	14	130	199.5	

AL Series

外形尺寸图表
Outline dimensional

AL120-L1[Single]

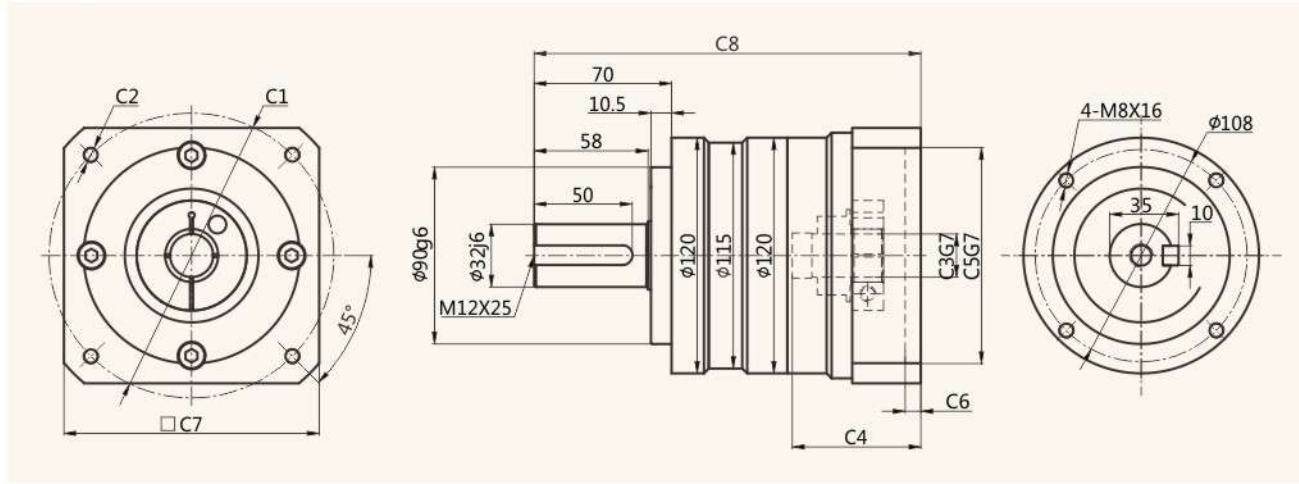

AL120-L2[Double]

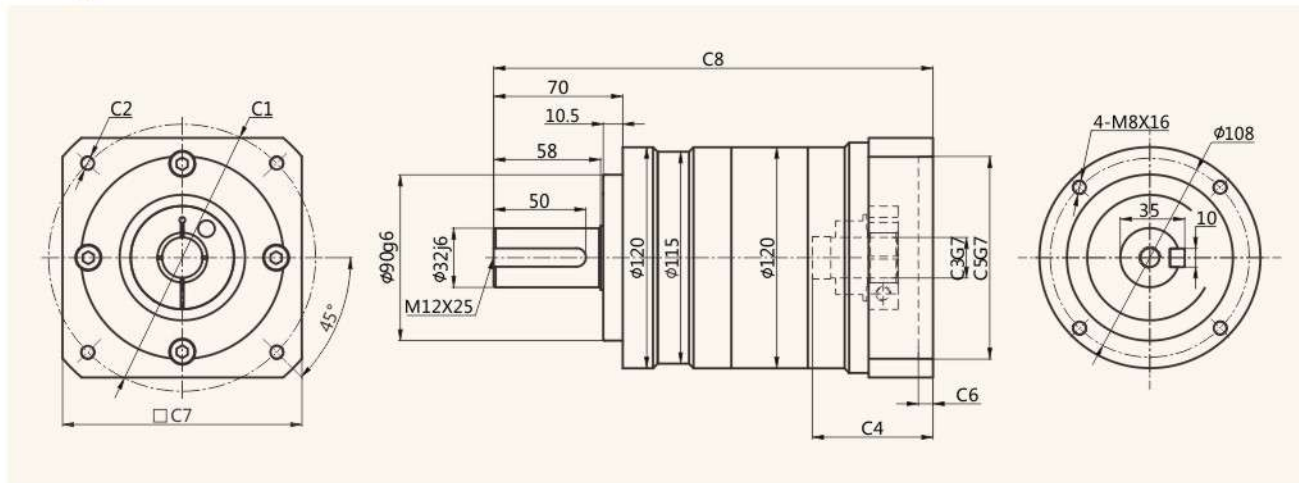

适配电机输入接口尺寸(左端为输入尺寸)
Adapter motor input interface size (The left end is the input size)

尺寸 Size	C1	C2	C3	C4	C5	C6	C7	C8
AL-120-L1	$\phi 115$	4-M8/4-M6	$\phi 19/\phi 22/\phi 24$	62.5	$\phi 95$	8	130	194
	$\phi 130$	4-M8	$\phi 19/\phi 22/\phi 24$	62.5	$\phi 95$	8	130	194
	$\phi 145$	4-M8	$\phi 19/\phi 22/\phi 24$	65.5	$\phi 110$	8	130	197
AL-120-L2	$\phi 90$	4-M5/4-M6	$\phi 19$	57.5	$\phi 70$	6	130	230.5
	$\phi 115$	4-M8/4-M6	$\phi 19/\phi 22/\phi 24$	62.5	$\phi 95$	8	130	235.5
	$\phi 130$	4-M8	$\phi 19/\phi 22/\phi 24$	62.5	$\phi 95$	8	130	235.5
	$\phi 145$	4-M8	$\phi 19/\phi 22/\phi 24$	65.5	$\phi 110$	8	130	238.5

外形尺寸图表
Outline dimensional

AL155-L1[Single]

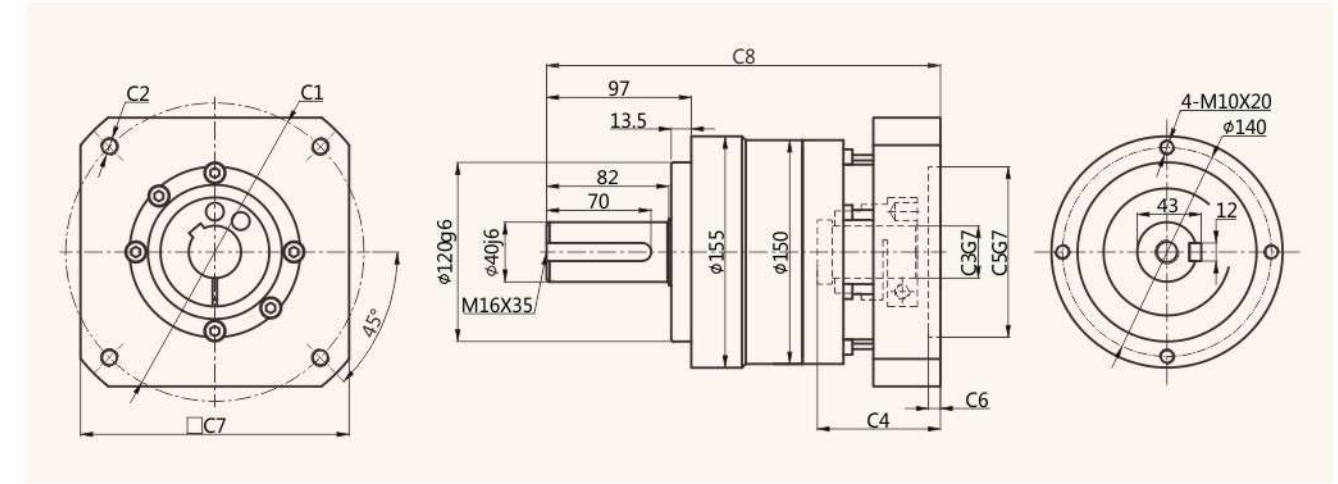

AL155-L2[Double]

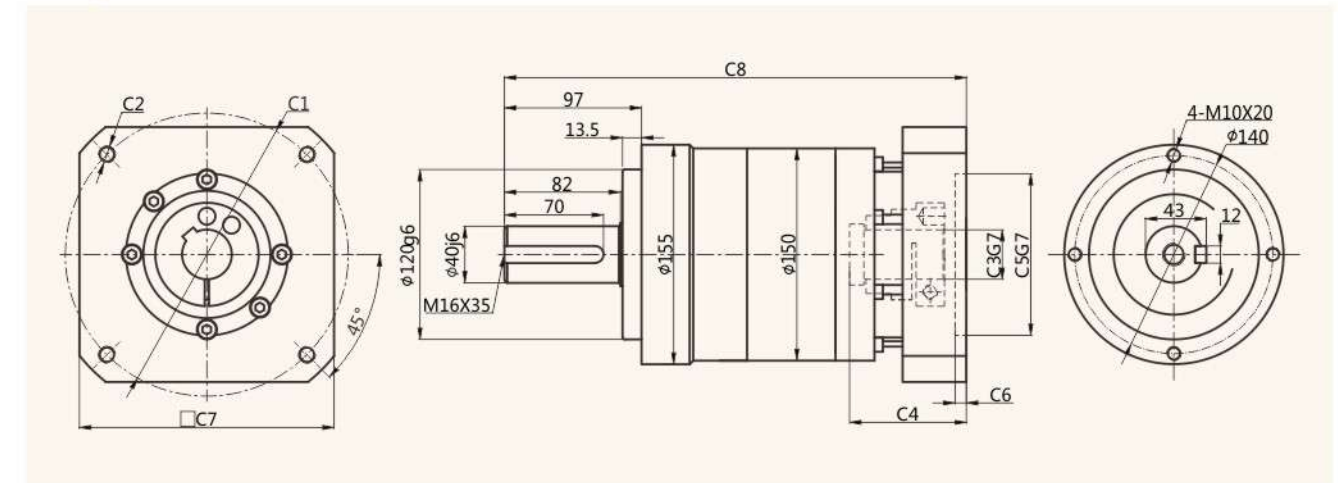

适配电机输入接口尺寸(左端为输入尺寸)
Adapter motor input interface size (The left end is the input size)

尺寸 Size	C1	C2	C3	C4	C5	C6	C7	C8
AL-155-L1	$\phi 115$	4-M8/M6	$\phi 22/\phi 24$	67.5	$\phi 95$	8	115	249
	$\phi 145$	4-M8	$\phi 22/\phi 24$	72.5	$\phi 110$	8	130	254
	$\phi 200$	4-M12	$\phi 35/\phi 38/\phi 42$	82.5	$\phi 114.3$	8	180	264
	$\phi 200$	4-M12	$\phi 35/\phi 42$	117	$\phi 114.3$	8	180	296.5
AL-155-L2	$\phi 115$	4-M8/M6	$\phi 22/\phi 24$	67.5	$\phi 95$	8	115	311.5
	$\phi 145$	4-M8	$\phi 22/\phi 24$	72.5	$\phi 110$	8	130	316.5
	$\phi 200$	4-M12	$\phi 35$	82.5	$\phi 114.3$	8	180	326.5

外形尺寸图表 Outline dimensional

AL205-L1[Single]

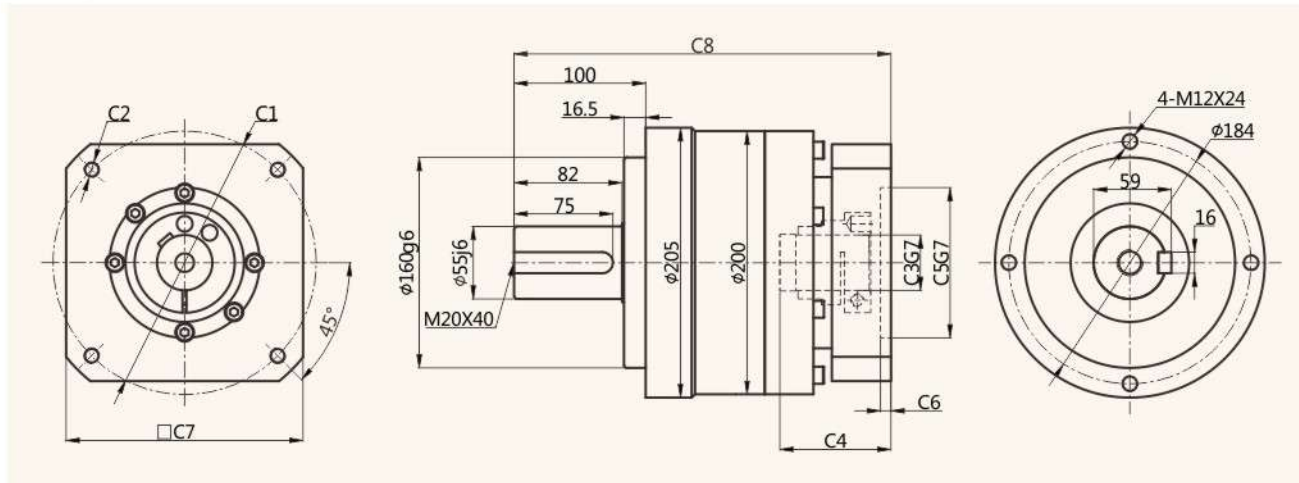

AL205-L2[Double]

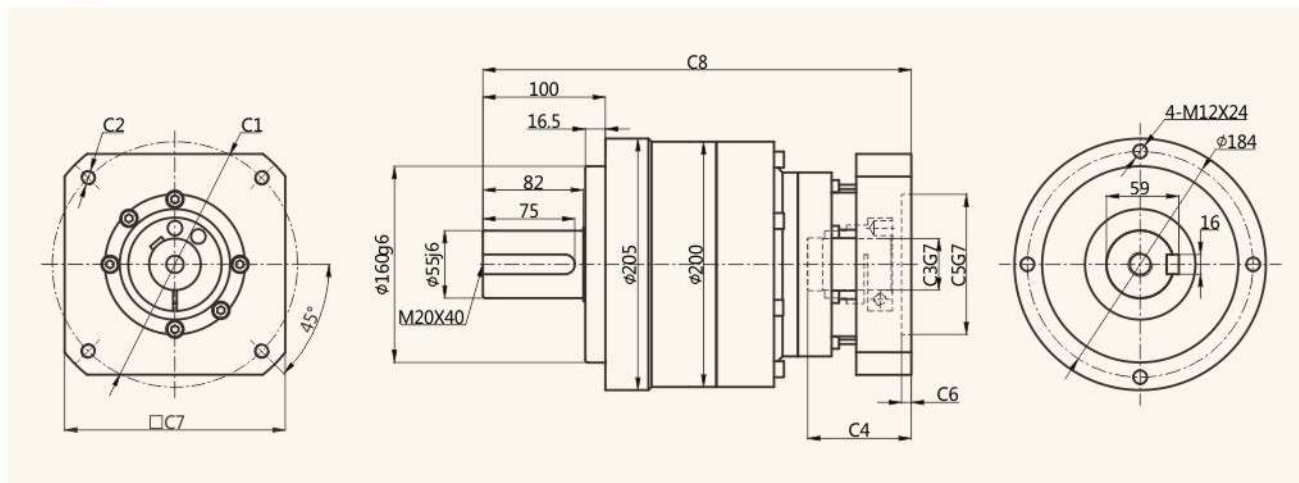

适配电机输入接口尺寸(左端为输入尺寸)
Adapter motor input interface size (The left end is the input size)

尺寸 Size	C1	C2	C3	C4	C5	C6	C7	C8
AL-205-L1	$\phi 200$	4-M12	$\phi 35/\phi 38/\phi 42$	82.5	$\phi 114.3$	8	180	286.5
	$\phi 200$	4-M12	$\phi 35/\phi 42$	117	$\phi 114.3$	8	180	319
	$\phi 215$	4-M12	$\phi 38/\phi 42$	87.5	$\phi 180$	8	200	291.5
AL-205-L2	$\phi 115$	4-M8/M6	$\phi 22/\phi 24$	67.5	$\phi 95$	8	115	334.5
	$\phi 145$	4-M8	$\phi 22/\phi 24$	72.5	$\phi 110$	8	130	339.5
	$\phi 200$	4-M12	$\phi 35/\phi 38/\phi 42$	82.5	$\phi 114.3$	8	180	349.5
	$\phi 200$	4-M12	$\phi 35/\phi 42$	117	$\phi 114.3$	8	180	382
	$\phi 215$	4-M12	$\phi 38/\phi 42$	87.5	$\phi 180$	8	200	354.5

- ✓ ALE070
- ✓ ALE090

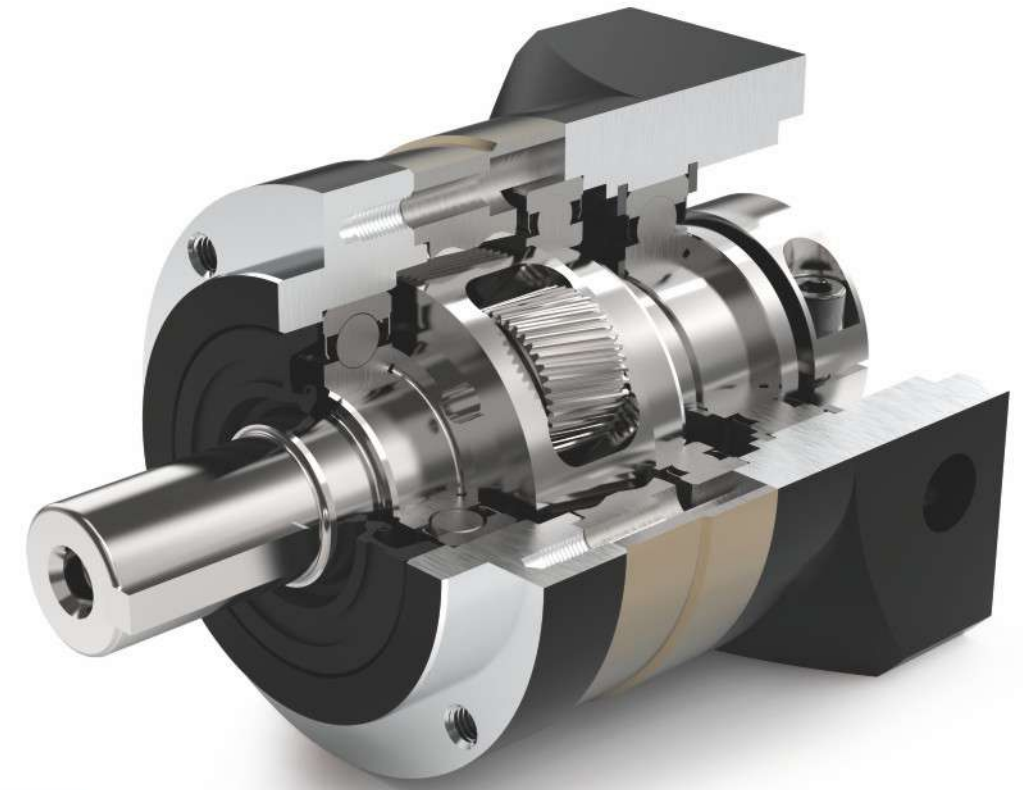

ALE Series

ALE系列减速机核心特性

The Core Characteristics of ALE Series Reducer

- 1 采用斜齿齿轮传动，经渗碳淬火处理，齿向齿廓修形处理，确保运行低噪音、平稳，承载能力较直齿提高20%；
- 2 整体式输出轴，行星轮两端轴承支撑，实现高精度、强度；
- 3 回程间隙小，精密型单级可以做到5arcmin以内。

- 1 Helical gear transmission, carburizing and quenching treatment, tooth profile modification treatment, to ensure low noise and smooth operation. The bearing capacity is 20% higher than that of straight teeth.
- 2 Integral output shaft and bearing support at both ends of planetary wheel to achieve high precision and strength.
- 3 The backlash clearance is small, and the precision single stage can achieve less than 5 arcmin.

- ✓ AXF042
- ✓ AXF060
- ✓ AXF090
- ✓ AXF115
- ✓ AXF142

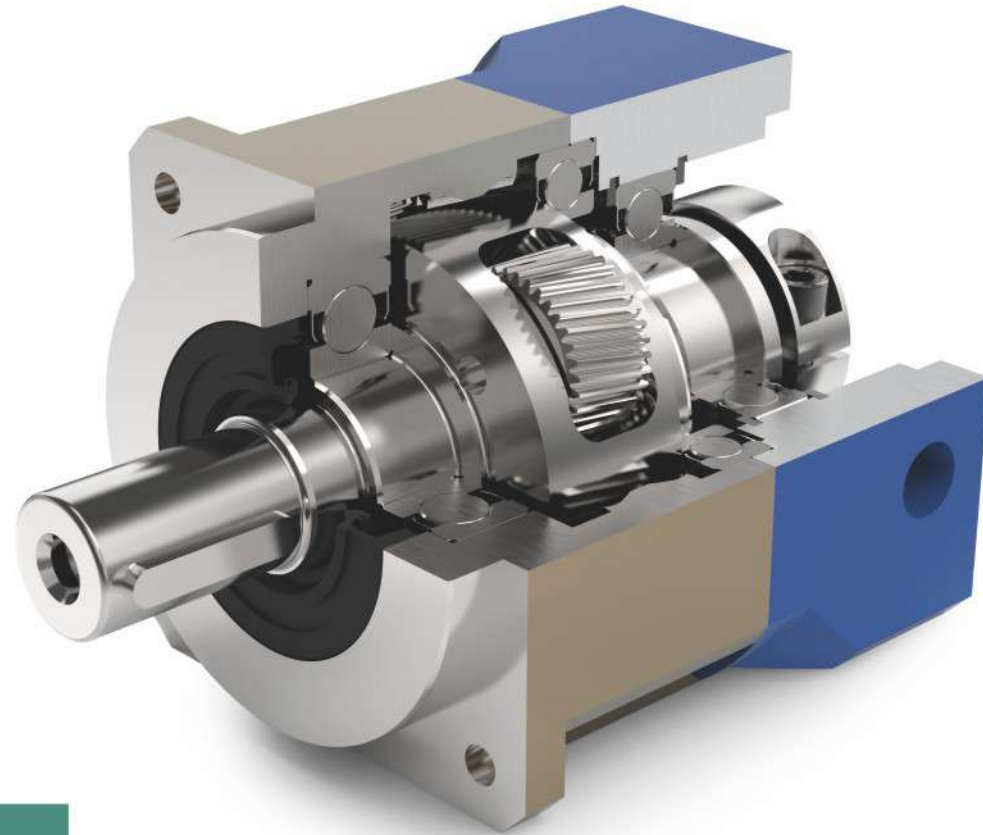

AXF Series

AXF系列减速机核心特性

The Core Characteristics of AXF Series Reducer

- 1 采用斜齿齿轮传动，经渗碳淬火处理，齿向齿廓修形处理，确保运行低噪音、平稳，承载能力较直齿提高20%；
- 2 整体式输出轴，行星轮两端轴承支撑，实现高精度、强度；
- 3 内齿圈采用整体式结构设计；
- 4 齿轮模数加大，更高的刚性；
- 5 大跨度轴承排列，超强径向承载能力；
- 6 回程间隙小，精密型单级可以做到3arcmin以内。

- 1 Helical gear transmission, carburizing and quenching treatment, tooth profile modification treatment, to ensure low noise and smooth operation. The bearing capacity is 20% higher than that of straight teeth.
- 2 Integral output shaft and bearing support at both ends of planetary wheel to achieve high precision and strength.
- 3 The inner gear ring adopts integral structure design.
- 4 Gear module increase, achieve higher rigidity.
- 5 Long span bearing arrangement, super radial bearing energy.
- 6 The backlash clearance is small, and the precision single stage can achieve less than 3 arcmin.

减速机性能资料

Gear box performance information

型号 Model	单位 Unit	AXF042	AXF060	AXF090	AXF115	AXF142	减速比 Ratio	Stage	
额定输出扭矩 Rated output torque	N·m	-	55	160	335	650	3	1	
		20	65	165	345	700	4		
		20	60	160	335	650	5		
		19	50	135	290	540	7		
		14	42	105	255	455	10		
		-	55	160	335	650	15		
		20	65	165	345	700	16	2	
		20	65	165	345	700	20		
		20	60	160	335	650	25		
		20	65	165	345	700	28		
		-	55	160	335	650	30		
		20	60	160	335	650	35		
		20	65	165	345	700	40		
		20	60	160	335	650	50		
		19	50	135	290	540	70		
		14	35	100	200	410	100		
故障停滞扭矩 Emergency stop torque	N·m	3倍额定输出扭矩 3 times Rated output torque							
额定输入转速 Norminal input speed	rpm	3000	3000	3000	3000	2000			
额定输入转速 Maximum input speed	rpm	6000	6000	6000	6000	4000			
最大径向力 ¹⁾ Maximum radial force	N	700	1500	3200	6700	9600			
最大轴向力 ¹⁾ Maximum axial force	N	380	760	1600	3300	4800			
效率 Efficiency	%	Single [97%]			Double [95%]				
平均寿命 Average lifetime	h	20000							
重量 (大概) Weight	kg	0.8	1.5	4	8.2	18		1	
		1.3	2.0	5.5	12	25		2	
转动惯量 Moment of inertia	kgcm ²	-	0.22	1.2	3.3	20	3	1	
		0.022	0.17	0.95	2	15	4		
		0.019	0.16	0.86	1.6	14	5		
		0.017	0.14	0.79	1.1	12	7		
		0.017	0.14	0.75	0.95	11	10		
		-	0.14	0.72	0.8	11	15		
		0.022	0.14	0.5	0.9	11	16	2	
		0.019	0.13	0.44	0.8	11	20		
		0.017	0.13	0.44	0.8	11	25		
		0.017	0.14	0.39	0.8	11	28		
		-	0.13	0.39	0.7	10	30		
		0.016	0.13	0.39	0.8	11	35		
		0.016	0.13	0.39	0.7	10	40		
		0.016	0.13	0.39	0.7	10	50		
		0.016	0.13	0.39	0.7	10	70		
		0.016	0.13	0.39	0.7	10	100		
0.019	0.13	0.39	0.7	10	100				
回程间隙 Backlash	arcmin	≤ 3	≤ 3	≤ 3	≤ 3	≤ 3	Precise[1]		
		≤ 5	≤ 5	≤ 5	≤ 5	≤ 5	Standard[1]		
		≤ 5	≤ 5	≤ 5	≤ 5	≤ 5	Precise[2]		
		≤ 7	≤ 7	≤ 7	≤ 7	≤ 7	Standard[2]		
抗扭刚性 Torsional rigidity	N·m/arc min	3	7	14	25	50			
噪音 Noise	dB	56	60	62	62	68			
润滑 Lubricating		合成油脂润滑 Synthetic grease lubrication							
防护等级 Levels of protection		IP65							

※1 输出转速为100rpm时，作用于输出轴中心位置

外形尺寸图表
Outline dimensional

AXF042-L1[Single]

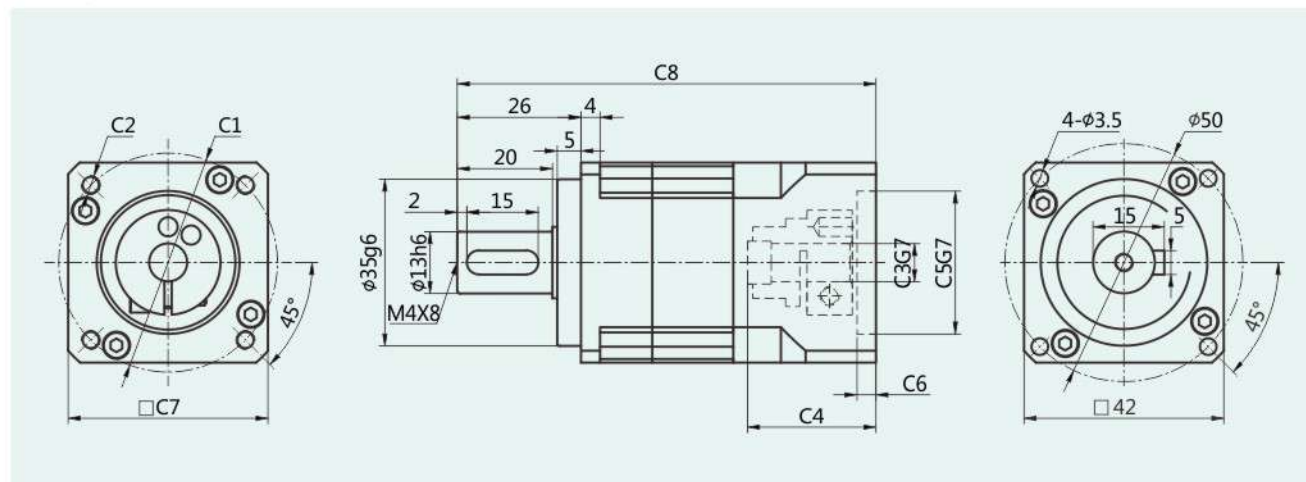

AXF042-L2[Double]

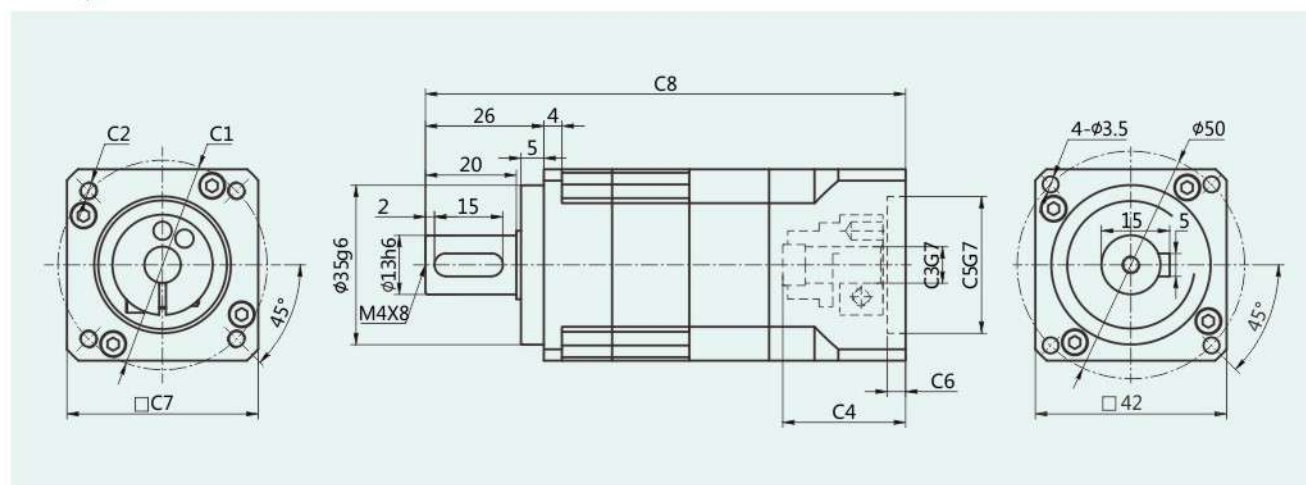

适配电机输入接口尺寸(左端为输入尺寸)
Adapter motor input interface size (The left end is the input size)

尺寸 Size	C1	C2	C3	C4	C5	C6	C7	C8
AXF-042-L1	φ46	4-M4	φ8	27	φ30	6	42	88
	φ45	4-M3	φ8	27	φ30	6	42	88
AXF-042-L2	φ46	4-M4	φ8	27	φ30	6	42	105.5
	φ45	4-M3	φ8	27	φ30	6	42	105.5

外形尺寸图表
Outline dimensional

AXF060-L1[Single]

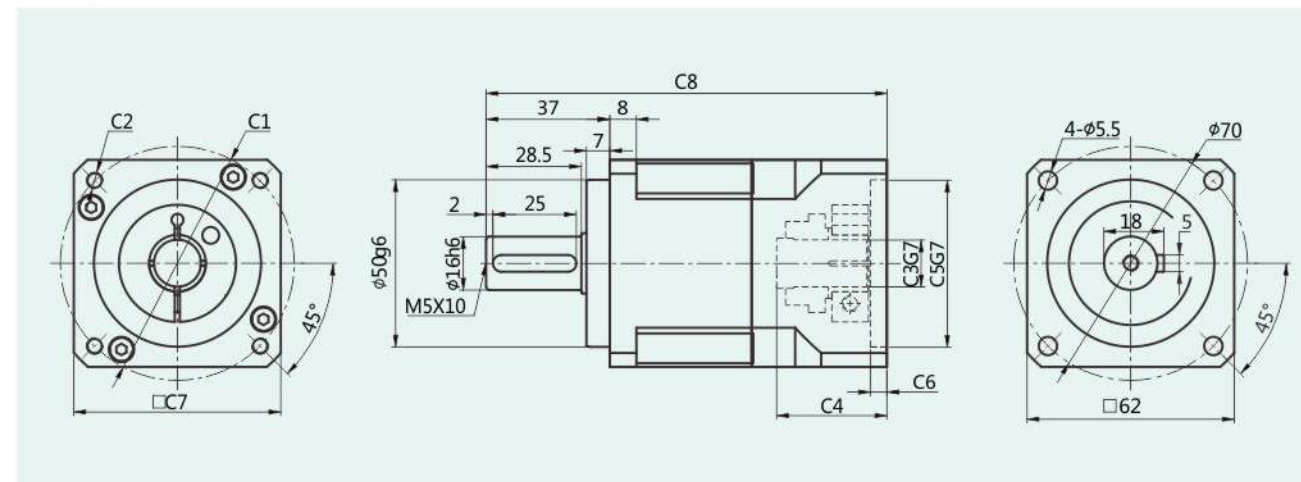

AXF060-L2[Double]

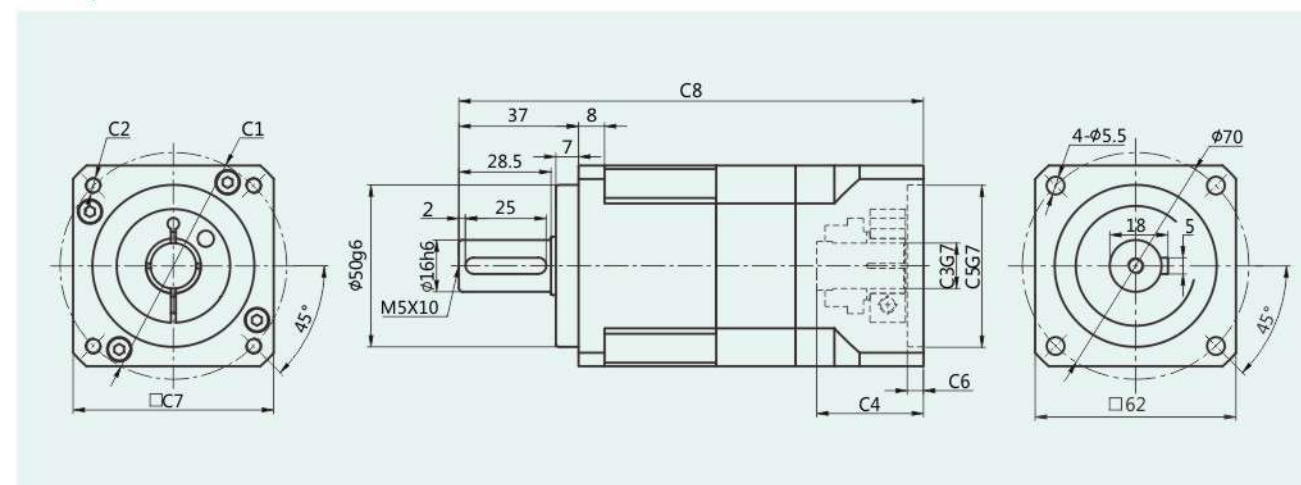

适配电机输入接口尺寸(左端为输入尺寸)
Adapter motor input interface size (The left end is the input size)

尺寸 Size	C1	C2	C3	C4	C5	C6	C7	C8
AXF-060-L1	φ70	4-M4/4-M5	φ14	33	φ50	5	62	120
AXF-060-L2	φ70	4-M4/4-M5	φ14	33	φ50	5	62	143.5

AXF Series

外形尺寸图表
Outline dimensional

AXF090-L1[Single]

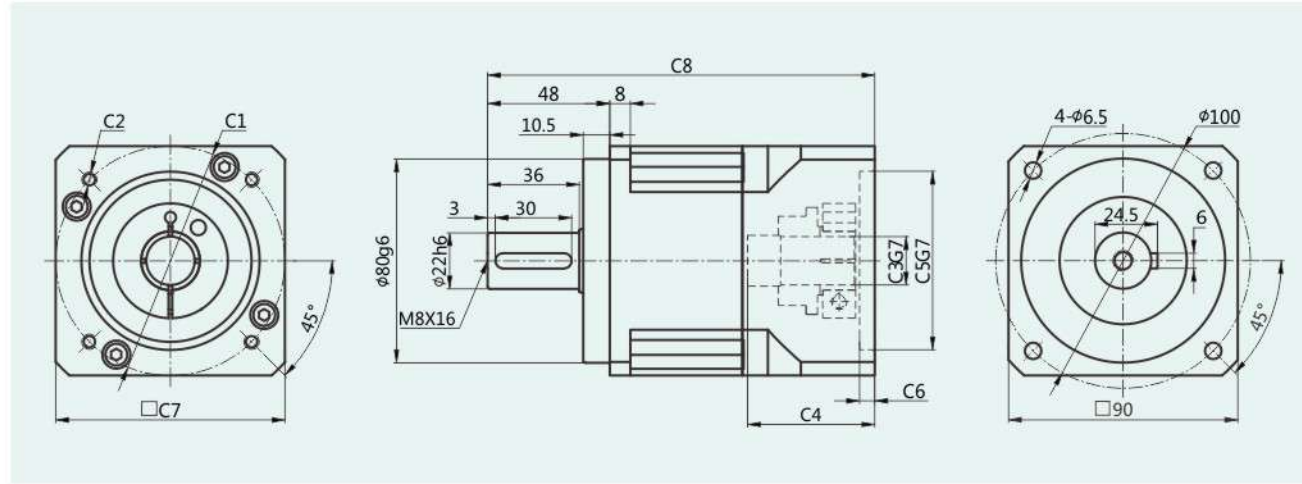

AXF090-L2[Double]

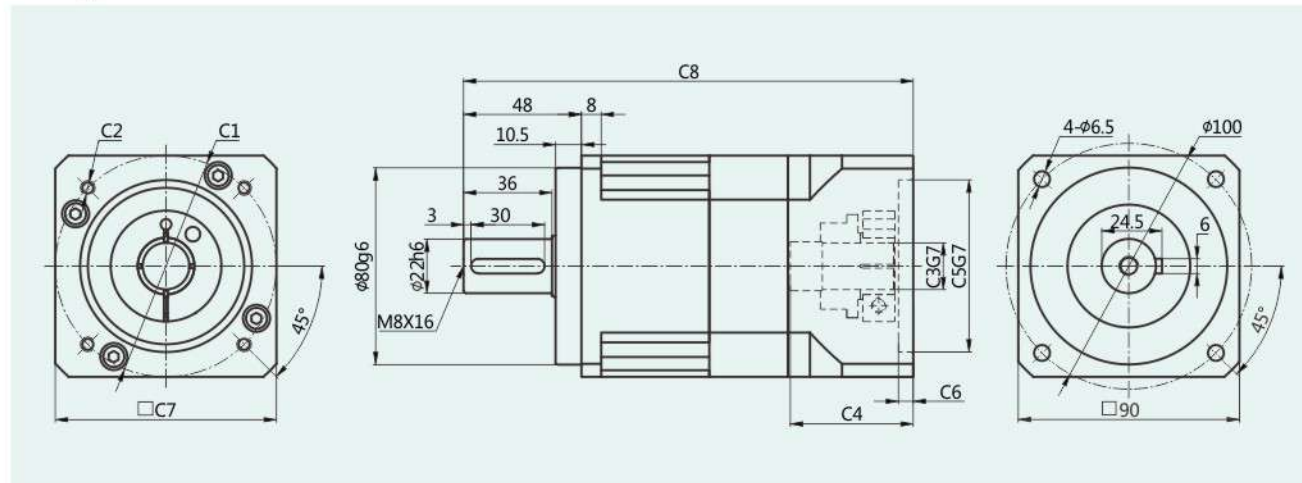

适配电机输入接口尺寸(左端为输入尺寸)
Adapter motor input interface size (The left end is the input size)

尺寸 Size	C1	C2	C3	C4	C5	C6	C7	C8
AXF-090-L1	Φ98.4	4-M6/4-M5	Φ14/Φ19	50	Φ73	6	90	152
	Φ90	4-M5/4-M6	Φ19	50	Φ70	6	90	152
	Φ115	4-M8	Φ19/Φ22	62	Φ95	8	110	164
	Φ130	4-M8	Φ19/Φ22	62	Φ95	8	110	164
	Φ145	4-M8	Φ19/Φ22/Φ24	65.5	Φ110	8	130	167.5
AXF-090-L2	Φ70	4-M4/4-M5	Φ14	38.5	Φ50	5	65	174
	Φ98.4	4-M6/4-M5	Φ14/Φ19	50	Φ73	6	90	181
	Φ90	4-M5/4-M6	Φ19	50	Φ70	6	90	183
	Φ115	4-M8	Φ19/Φ22	62	Φ95	8	110	195
	Φ130	4-M8	Φ19/Φ22	62	Φ95	8	110	195
Φ145	4-M8	Φ19/Φ22	65.5	Φ110	8	130	198.5	

外形尺寸图表
Outline dimensional

AXF115-L1[Single]

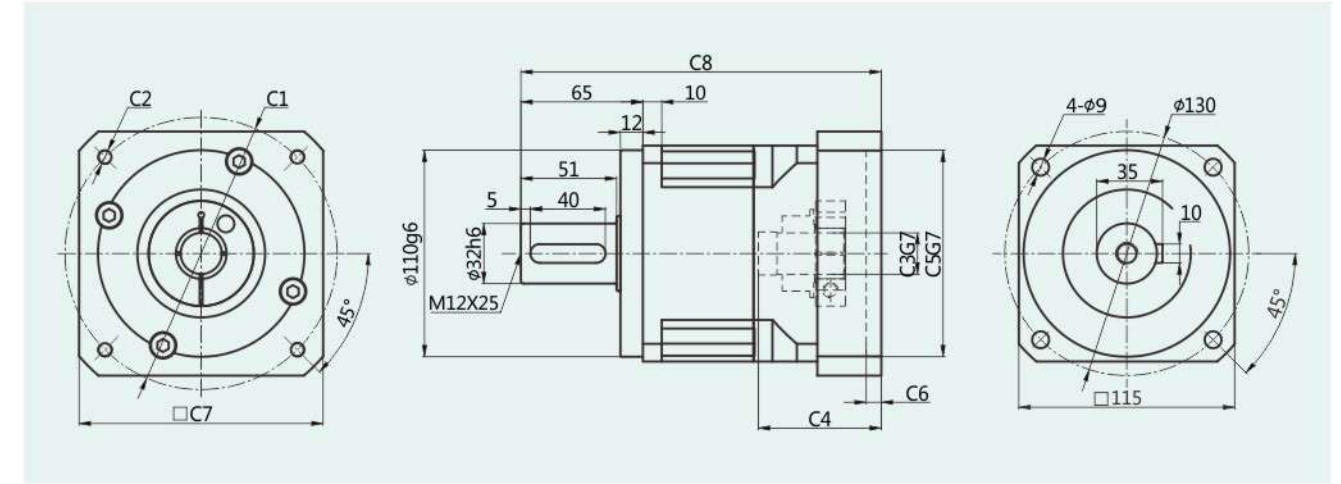

AXF115-L2[Double]

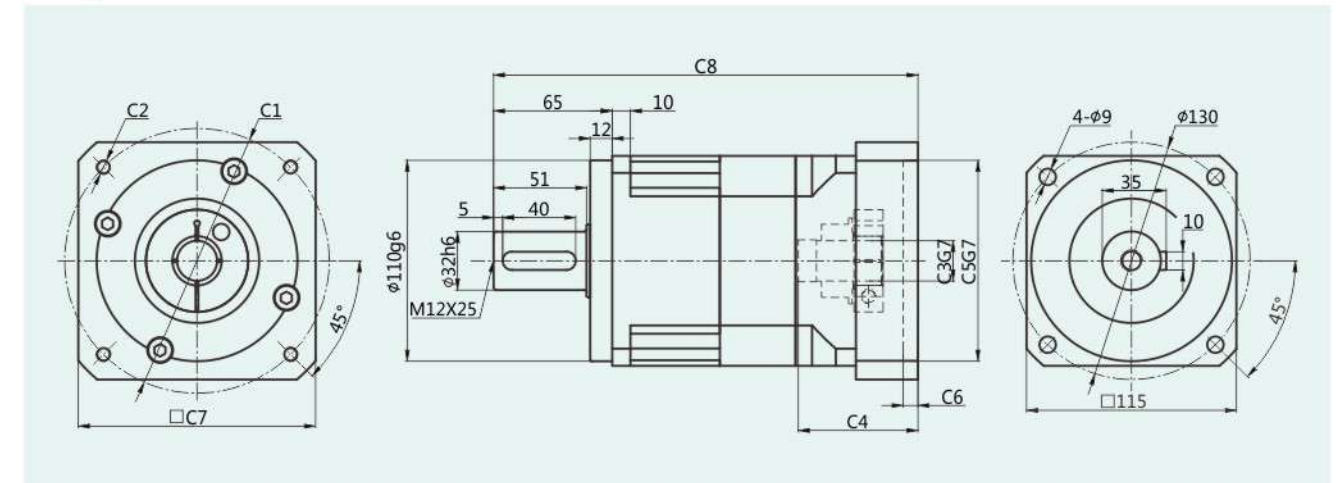

适配电机输入接口尺寸(左端为输入尺寸)
Adapter motor input interface size (The left end is the input size)

尺寸 Size	C1	C2	C3	C4	C5	C6	C7	C8
AXF-115-L1	Φ115	4-M8/4-M6	Φ19/Φ22/Φ24	62.5	Φ95	8	130	189
	Φ130	4-M8	Φ19/Φ22/Φ24	62.5	Φ95	8	130	189
	Φ145	4-M8	Φ19/Φ22/Φ24	65.5	Φ110	8	130	192
AXF-115-L2	Φ90	4-M5/4-M6	Φ19	57.5	Φ70	6	130	224.5
	Φ115	4-M8/4-M6	Φ19/Φ22/Φ24	62.5	Φ95	8	130	229.5
	Φ130	4-M8	Φ19/Φ22/Φ24	62.5	Φ95	8	130	229.5
Φ145	4-M8	Φ19/Φ22/Φ24	65.5	Φ110	8	130	232.5	

外形尺寸图表 Outline dimensional

AXF142-L1[Single]

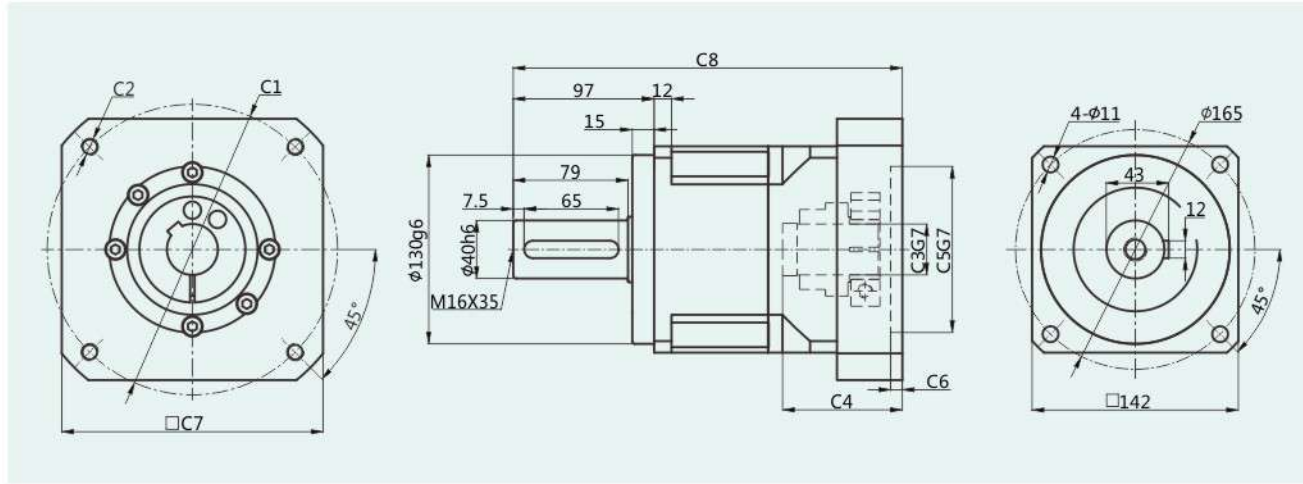

AXF142-L2[Double]

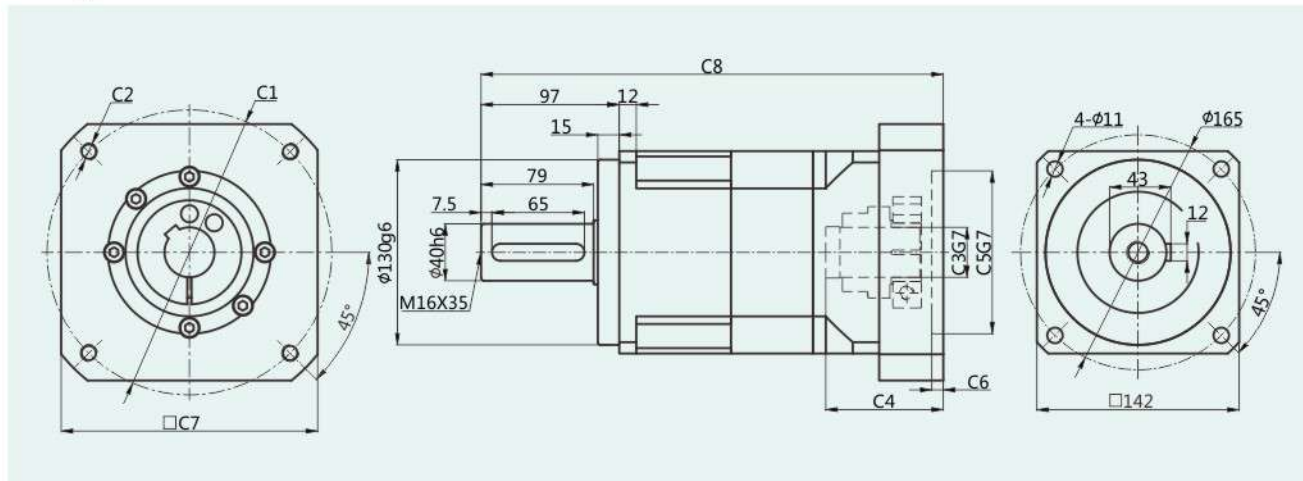

适配电机输入接口尺寸(左端为输入尺寸)
Adapter motor input interface size (The left end is the input size)

尺寸 Size	C1	C2	C3	C4	C5	C6	C7	C8
AXF-142-L1	Φ200	4-M12	Φ35/Φ38/Φ42	82.5	Φ114.3	8	180	268
	Φ200	4-M12	Φ35/Φ42	117	Φ114.3	8	180	300.5
	Φ215	4-M12	Φ38/Φ42	87.5	Φ180	8	200	273
AXF-142-L2	Φ115	4-M8/M6	Φ22/Φ24	67.5	Φ95	8	115	309.5
	Φ145	4-M8	Φ22/Φ24	72.5	Φ110	8	130	314.5
	Φ200	4-M12	Φ35	82.5	Φ114.3	8	180	324.5

- AH064
- AGH090
- AGH110
- AGH140
- AGH200

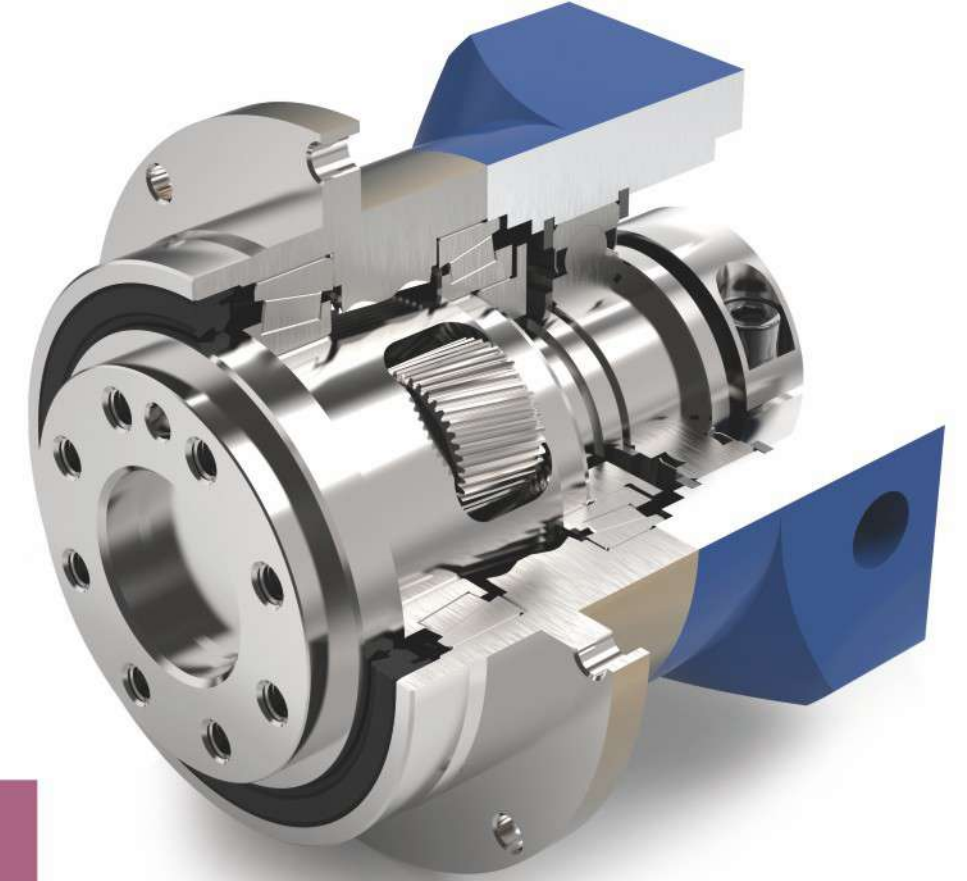

AGH Series

AGH系列减速机核心特性 The Core Characteristics of AGH Series Reducer

- 1 采用斜齿齿轮传动，经渗碳淬火处理，齿向齿廓修形处理，确保运行低噪音、平稳，承载能力较直齿提高20%；
- 2 整体式输出轴，行星轮两端轴承支撑，实现高精度、强度；
- 3 内齿圈采用整体式结构设计；
- 4 前后大跨度圆锥滚子轴承排列，超强径向和轴向承载能力（AH064除外）；
- 5 回程间隙小，精密型单级可以做到3arcmin以内。

- 1 Helical gear transmission, carburizing and quenching treatment, tooth profile modification treatment, to ensure low noise and smooth operation. The bearing capacity is 20% higher than that of straight teeth.
- 2 Integral output shaft and bearing support at both ends of planetary wheel to achieve high precision and strength.
- 3 The inner gear ring adopts integral structure design.
- 4 Arrangement of front and rear large span tapered roller bearings, Super strong radial and axial bearing capacity(Except AH064 Series).
- 5 The backlash clearance is small, and the precision single stage can achieve less than 3 arcmin.

外形尺寸图表
Outline dimensional

AGH090-L1[Single]

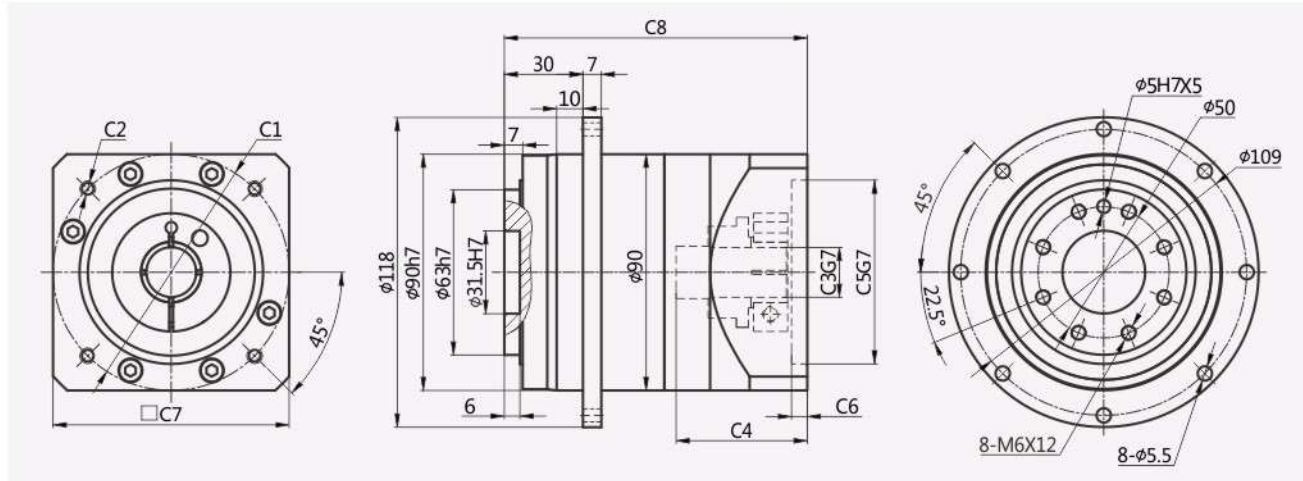

AGH090-L2[Double]

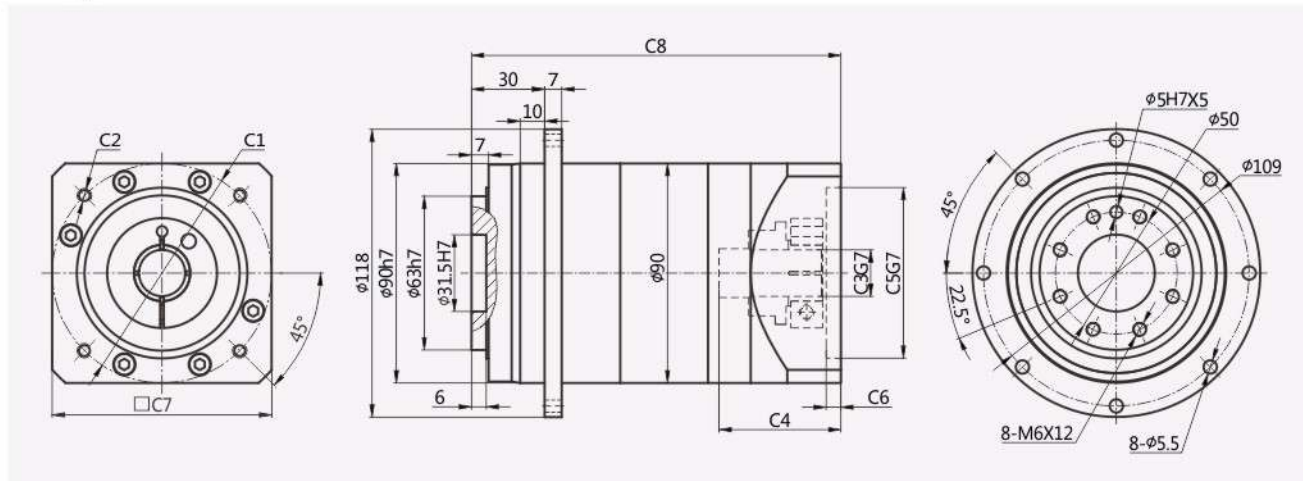

适配电机输入接口尺寸(左端为输入尺寸)
Adapter motor input interface size (The left end is the input size)

尺寸 Size	C1	C2	C3	C4	C5	C6	C7	C8
AGH-090-L1	Φ98.4	4-M6/4-M5	Φ14/Φ19	50	Φ73	6	90	115.5
	Φ90	4-M5/4-M6	Φ19	50	Φ70	6	90	115.5
	Φ115	4-M8	Φ19/Φ22	62	Φ95	8	110	127.5
	Φ130	4-M8	Φ19/Φ22	62	Φ95	8	110	127.5
AGH-090-L2	Φ145	4-M8	Φ19/Φ22/Φ24	65.5	Φ110	14	130	131
	Φ70	4-M4/4-M5	Φ14	38.5	Φ50	5	65	142.5
	Φ98.4	4-M6/4-M5	Φ14/Φ19	50	Φ73	6	90	151.5
	Φ90	4-M5/4-M6	Φ19	50	Φ70	6	90	151.5
	Φ115	4-M8	Φ19/Φ22	62	Φ95	8	110	163.5
AGH-090-L2	Φ130	4-M8	Φ19/Φ22	62	Φ95	8	110	163.5
	Φ145	4-M8	Φ19/Φ22/Φ24	65.5	Φ110	14	130	167

外形尺寸图表
Outline dimensional

AGH110-L1[Single]

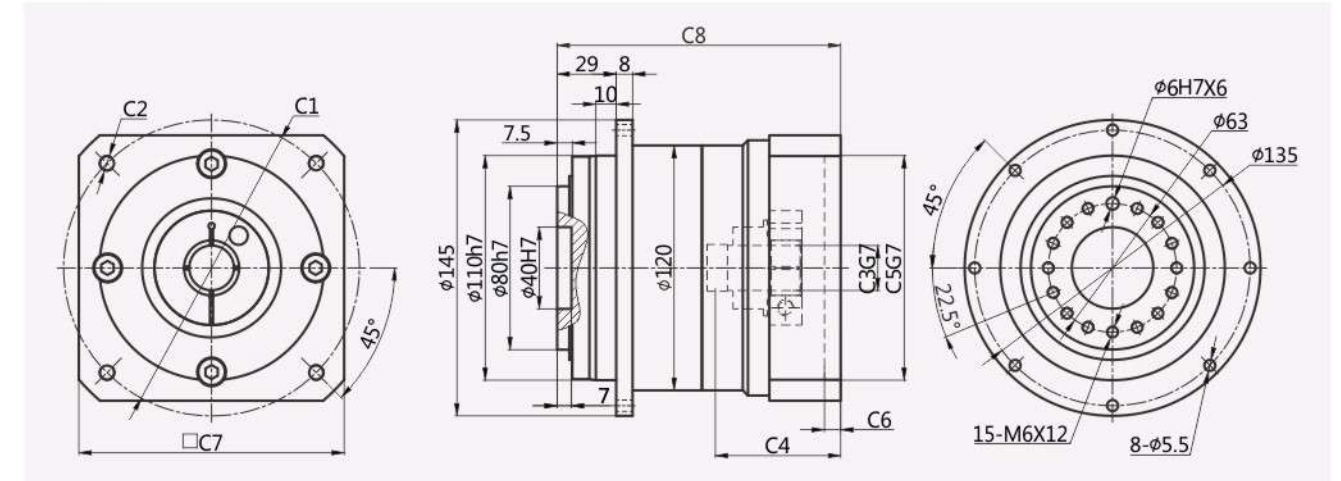

AGH110-L2[Double]

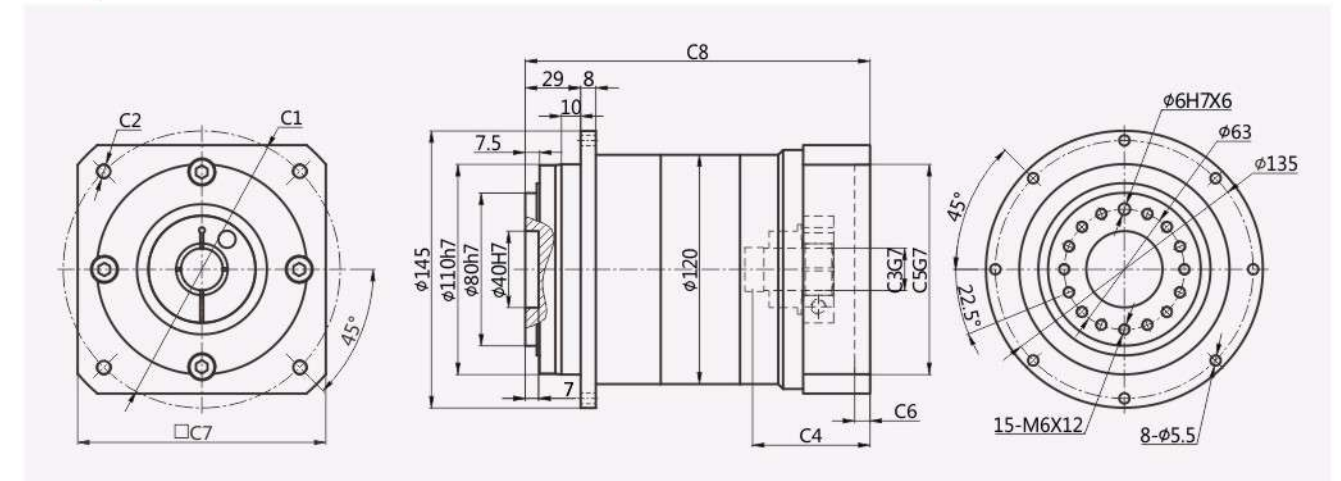

适配电机输入接口尺寸(左端为输入尺寸)
Adapter motor input interface size (The left end is the input size)

尺寸 Size	C1	C2	C3	C4	C5	C6	C7	C8
AGH-110-L1	Φ115	4-M8/4-M6	Φ19/Φ22/Φ24	62.5	Φ95	8	130	136
	Φ130	4-M8	Φ19/Φ22/Φ24	62.5	Φ95	8	130	136
	Φ145	4-M8	Φ19/Φ22/Φ24	65.5	Φ110	8	130	139
AGH-110-L2	Φ90	4-M5/4-M6	Φ19	57.5	Φ70	6	130	172.5
	Φ115	4-M8/4-M6	Φ19/Φ22/Φ24	62.5	Φ95	8	130	172.5
	Φ130	4-M8	Φ19/Φ22/Φ24	62.5	Φ95	8	130	172.5
	Φ145	4-M8	Φ19/Φ22/Φ24	65.5	Φ110	8	130	180.5

外形尺寸图表
Outline dimensional

AGH140-L1[Single]

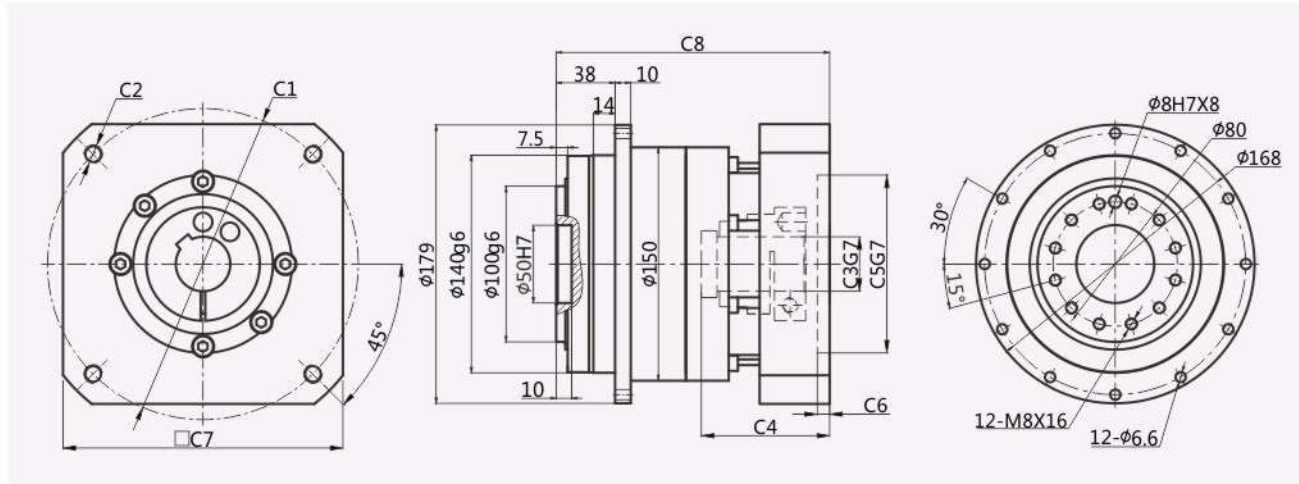

AGH140-L2[Double]

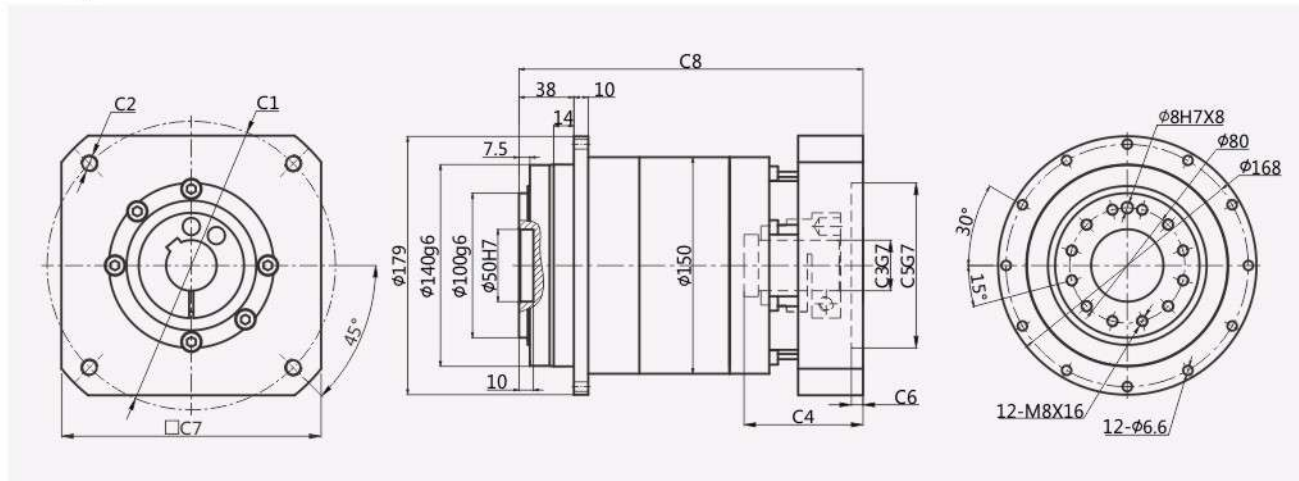

适配电机输入接口尺寸(左端为输入尺寸)
Adapter motor input interface size (The left end is the input size)

尺寸 Size	C1	C2	C3	C4	C5	C6	C7	C8
AGH-140-L1	φ115	4-M8/M6	φ22/φ24	67.5	φ95	8	115	161
	φ145	4-M8	φ22/φ24	72.5	φ110	8	130	166
	φ200	4-M12	φ35/φ38/φ42	82.5	φ114.3	8	180	176
	φ200	4-M12	φ35/φ42	117	φ114.3	8	180	208.5
	φ215	4-M12	φ38/φ42	87.5	φ180	8	200	181
AGH-140-L2	φ115	4-M8/M6	φ22/φ24	67.5	φ95	8	115	223.5
	φ145	4-M8	φ22/φ24	72.5	φ110	8	130	228.5
	φ200	4-M12	φ35	82.5	φ114.3	8	180	238.5

外形尺寸图表
Outline dimensional

AGH200-L1[Single]

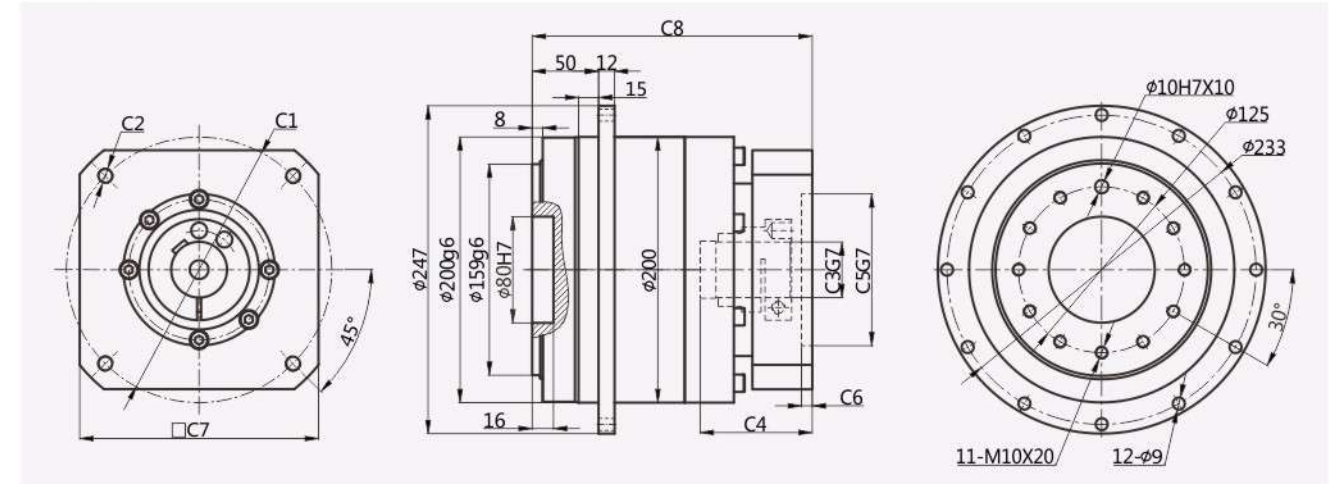

AGH200-L2[Double]

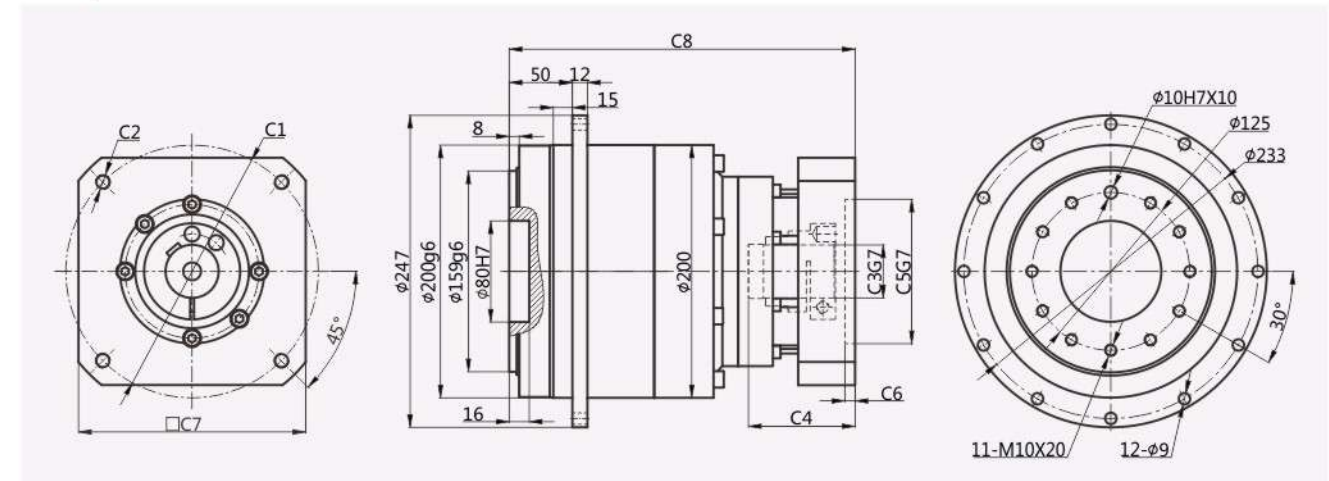

适配电机输入接口尺寸(左端为输入尺寸)
Adapter motor input interface size (The left end is the input size)

尺寸 Size	C1	C2	C3	C4	C5	C6	C7	C8
AGH-200-L1	φ200	4-M12	φ35/φ38/φ42	82.5	φ114.3	8	180	211
	φ200	4-M12	φ35/φ42	117	φ114.3	8	180	243.5
	φ215	4-M12	φ38/φ42	87.5	φ180	8	200	216
AGH-200-L2	φ115	4-M8/M6	φ22/φ24	67.5	φ95	8	115	259
	φ145	4-M8	φ22/φ24	72.5	φ110	8	130	264
	φ200	4-M12	φ35/φ38/φ42	82.5	φ114.3	8	180	274
	φ200	4-M12	φ35/φ42	117	φ114.3	8	180	306.5
	φ215	4-M12	φ38/φ42	87.5	φ180	8	200	279

- ✓ ZAXF042
- ✓ ZAF060
- ✓ ZAF090
- ✓ ZAF115
- ✓ ZAF140
- ✓ ZAF180



ZAF

Series

ZAF系列减速机核心特性

The Core Characteristics of ZAF Series Reducer

- 1 采用斜齿齿轮传动，经渗碳淬火处理，齿向齿廓修形处理，确保运行低噪音、平稳；承载能力较直齿提高20%；
- 2 整体式输出轴，行星轮两端轴承支撑，实现高精度、强度；
- 3 伞齿轮采用磨齿工艺精度可达6级，确保运行低噪音、平稳；
- 4 回程间隙小，精密型单级可以做到5arcmin以内。

- 1 Helical gear transmission, carburizing and quenching treatment, tooth profile modification treatment, to ensure low noise and smooth operation. The bearing capacity is 20% higher than that of straight teeth.
- 2 Integral output shaft and bearing support at both ends of planetary wheel to achieve high precision and strength. to ensure low noise and smooth operation.
- 3 The bevel gear adopts gear grinding technology, and the accuracy grade can reach grade 6.
- 4 The backlash clearance is small, and the precision single stage can achieve less than 5 arcmin.

减速机性能资料

Gear box performance information

型号 Model	单位 Unit	ZAXF042	ZAF060	ZAF090	ZAF115	ZAF140	ZAF180	减速比 Ratio	Stage		
额定输出扭矩 Rated output torque	N·m	-	35	100	230	450	1000	3	1		
		20	45	110	270	580	1300	4			
		20	44	105	255	540	1100	5			
		19	40	100	180	390	800	7			
		14	22	50	120	230	460	10			
		-	35	100	230	450	1000	15			
		20	45	110	270	580	1300	16	2		
		20	45	110	270	580	1300	20			
		20	44	105	255	540	1100	25			
		20	45	110	270	580	1300	28			
		-	35	100	230	450	1000	30			
		20	44	105	255	540	1100	35			
		20	45	110	270	580	1300	40			
		20	44	105	255	540	1100	50			
19	40	100	180	390	800	70					
14	22	50	120	230	460	100					
故障停滞扭矩 Emergency stop torque	N·m	3倍额定输出扭矩 3 times Rated output torque									
额定输入转速 Norminal input speed	rpm	3000	3000	3000	3000	2000	1500				
额定输入转速 Maximum input speed	rpm	6000	6000	6000	6000	4000	3000				
最大径向力 ¹⁾ Maximum radial force	N	700	920	1400	3000	5800	9500				
最大轴向力 ¹⁾ Maximum axial force	N	380	630	600	2500	4500	6800				
效率 Efficiency	%	Single [95%]			Double [93%]						
平均寿命 Average lifetime	h	20000									
重量 (大概) Weight	kg	1.1	2.1	5.6	11	24	39		1		
		1.8	2.6	6.6	14	30	45		2		
转动惯量 Moment of inertia	kgcm ²	-	0.39	2.45	6.7	27	44	3	1		
		0.022	0.34	2.22	5.4	22	28	4			
		0.019	0.32	2.13	5	21	22	5			
		0.017	0.31	2.06	4.6	19	16	7			
		0.017	0.3	2.02	4.4	19	14	10			
		-	0.11	0.6	0.8	15	12	15			
		0.022	0.12	0.65	0.9	15	13	16	2		
		0.019	0.11	0.59	0.8	14	12	20			
		0.017	0.11	0.59	0.8	14	12	25			
		0.017	0.12	0.64	0.8	15	13	28			
		-	0.10	0.51	0.7	13	11	30			
		0.016	0.11	0.59	0.8	14	12	35			
		0.016	0.10	0.51	0.7	13	11	40			
		0.016	0.10	0.51	0.7	13	11	50			
		0.016	0.10	0.51	0.7	13	11	70			
		0.019	0.10	0.51	0.7	13	11	100			
		回程间隙 Backlash	arcmin	≤7	≤7	≤7	≤7	≤10		≤10	Precise[1]
				≤10	≤10	≤10	≤10	≤12		≤12	Standard[1]
≤10	≤10			≤10	≤10	≤12	≤12	Precise[2]			
≤12	≤12			≤12	≤12	≤14	≤14	Standard[2]			
抗扭刚性 Torsional rigidity	N·m/arc min	3	7	14	25	50	145				
噪音 Noise	dB	60	65	65	68	70	75				
润滑 lubricating		合成油脂润滑 Synthetic grease lubrication									
防护等级 levels of protection		IP65									

※1 输出转速为100rpm时，作用于输出轴中心位置

外形尺寸图表
Outline dimensional

ZAXF042-L1[Single]

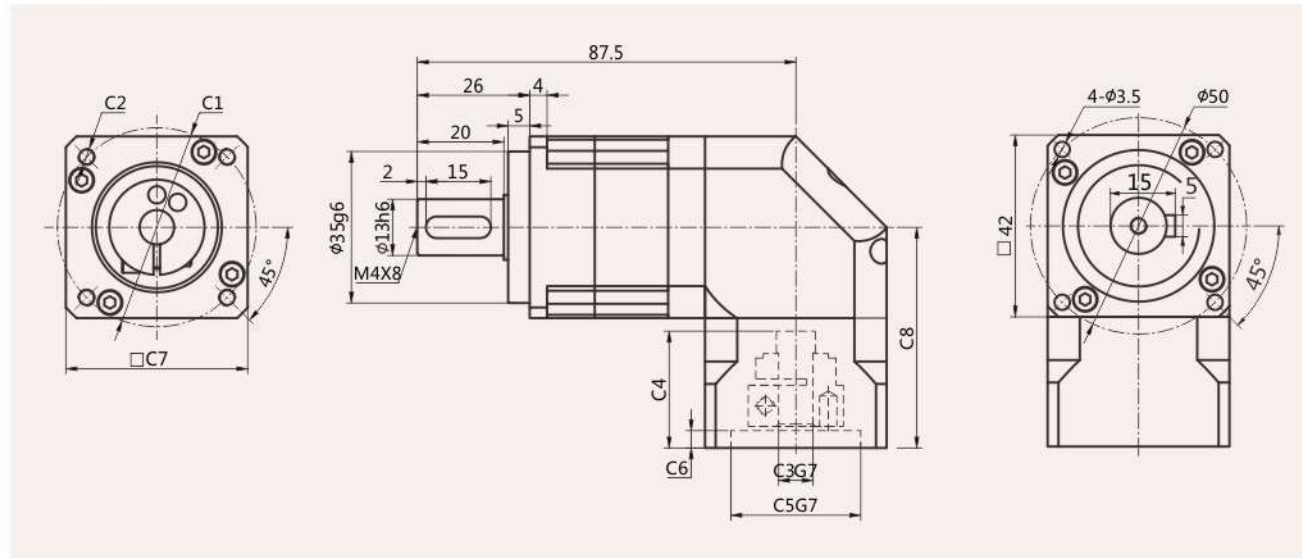

ZAXF042-L2[Double]

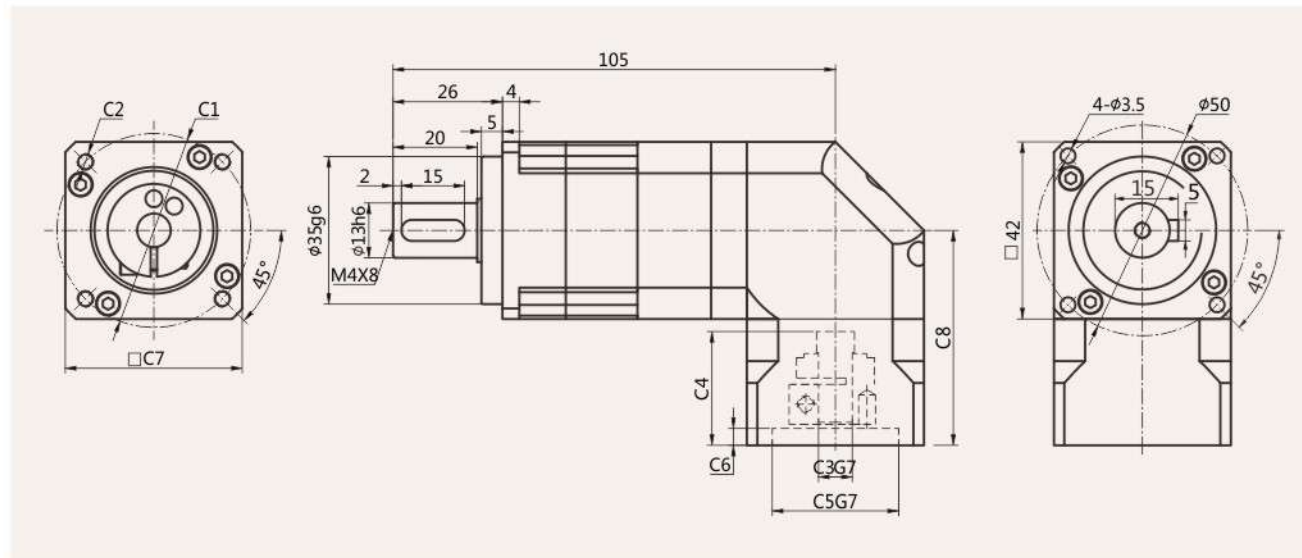

适配电机输入接口尺寸(左端为输入尺寸)
Adapter motor input interface size (The left end is the input size)

尺寸 Size	C1	C2	C3	C4	C5	C6	C7	C8
ZAXF-042-L1	φ46	4-M4	φ8	27	φ30	6	42	51
	φ45	4-M3	φ8	27	φ30	6	42	51
ZAXF-042-L2	φ46	4-M4	φ8	27	φ30	6	42	51
	φ45	4-M3	φ8	27	φ30	6	42	51

外形尺寸图表
Outline dimensional

ZAF060-L1[Single]

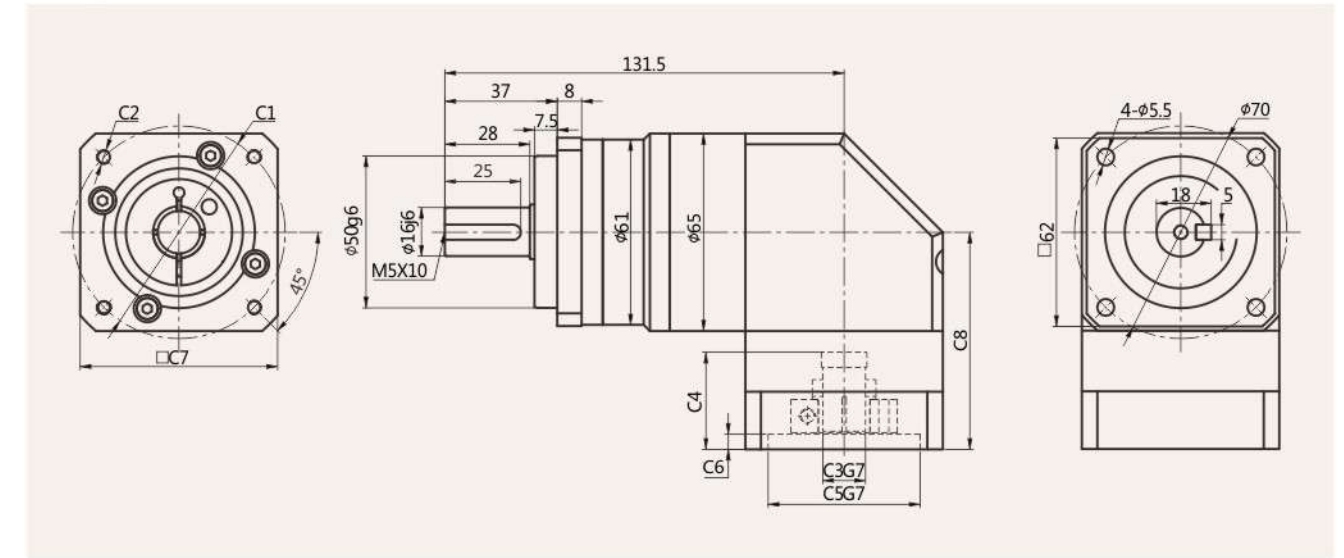

ZAF060-L2[Double]

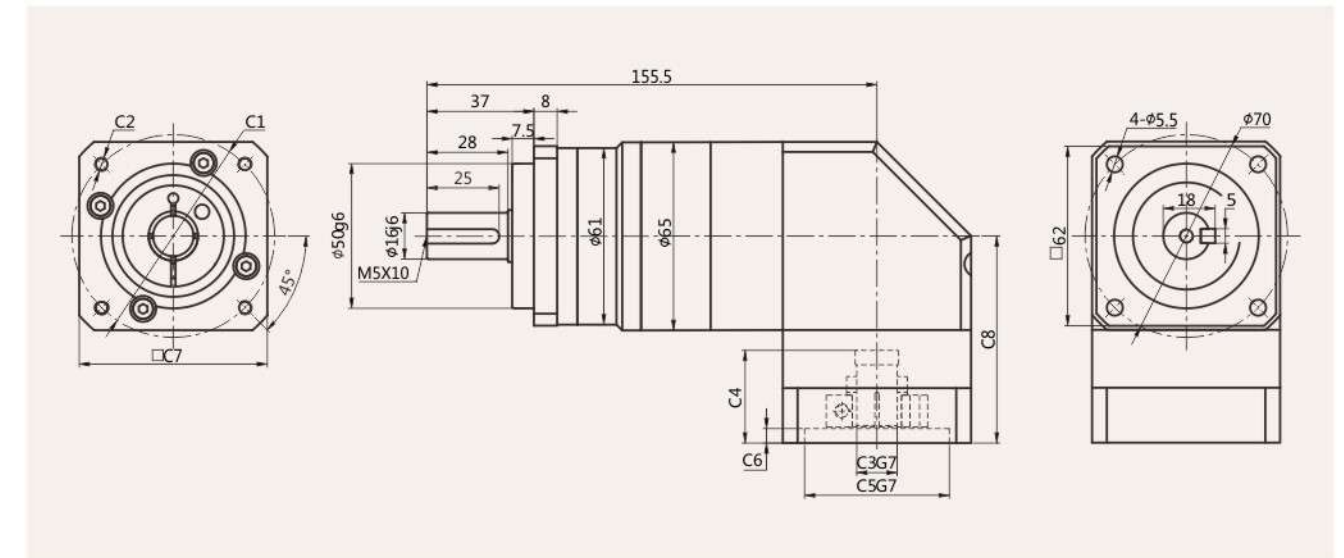

适配电机输入接口尺寸(左端为输入尺寸)
Adapter motor input interface size (The left end is the input size)

尺寸 Size	C1	C2	C3	C4	C5	C6	C7	C8
ZAF-060-L1	φ70	4-M4/4-M5	φ14	32	φ50	5	65	71.5
ZAF-060-L2	φ70	4-M4/4-M5	φ14	32	φ50	5	65	71.5

ZAF Series

外形尺寸图表
Outline dimensional

ZAF090-L1[Single]

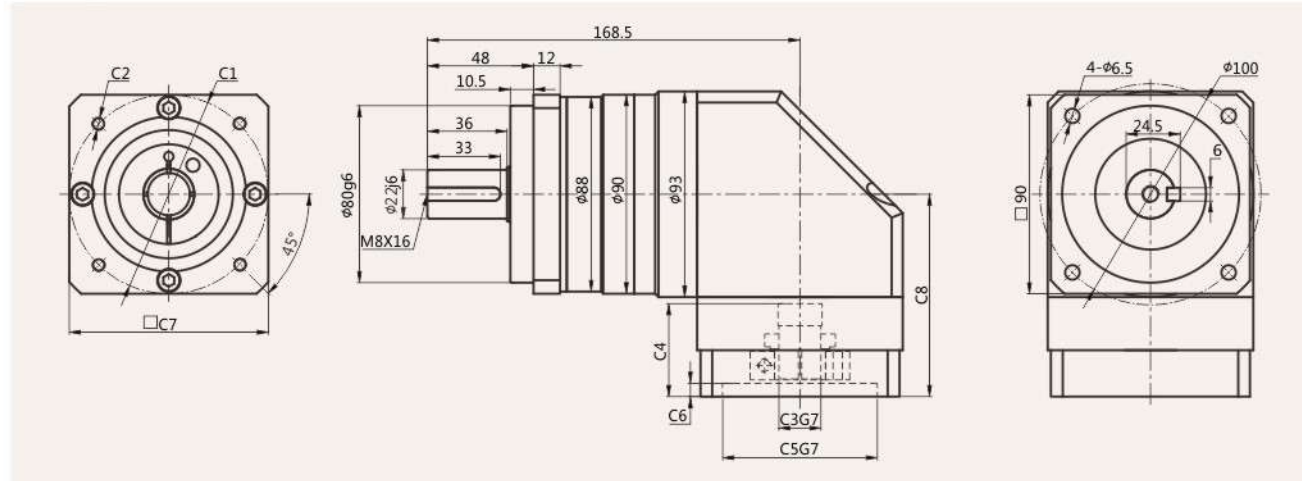

ZAF090-L2[Double]

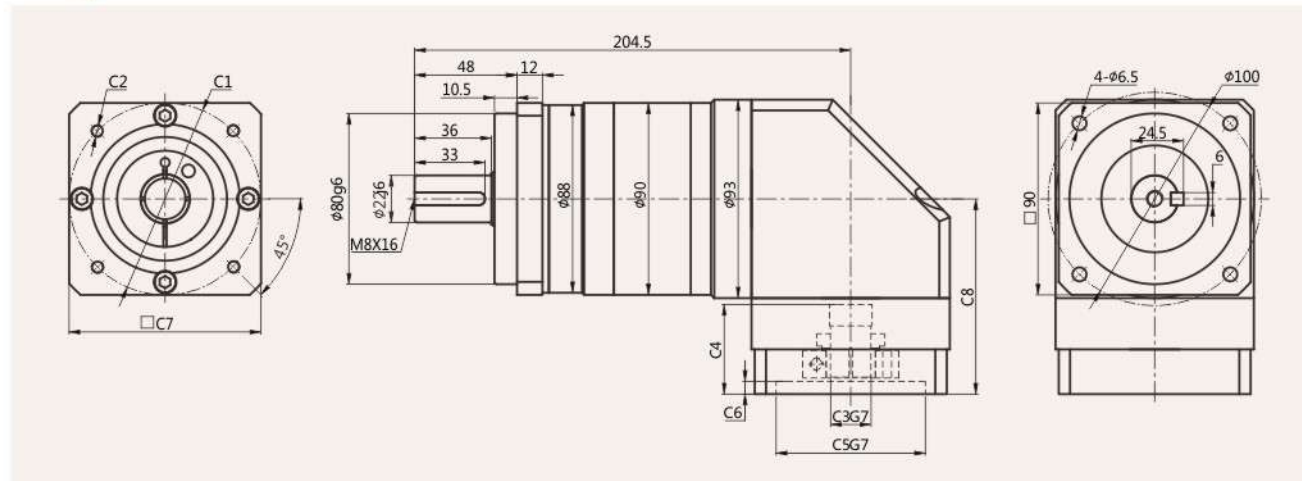

适配电机输入接口尺寸(左端为输入尺寸)
Adapter motor input interface size (The left end is the input size)

尺寸 Size	C1	C2	C3	C4	C5	C6	C7	C8
ZAF-090-L1	φ98.4	4-M6/4-M5	φ14/φ19	42	φ73	6	90	91.5
	φ90	4-M5/4-M6	φ19	42	φ70	6	90	91.5
	φ115	4-M8	φ19/φ22	54	φ95	8	110	103.5
	φ130	4-M8	φ19/φ22	54	φ95	8	110	103.5
	φ145	4-M8	φ19/φ22	57.5	φ110	8	130	107
ZAF-090-L2	φ98.4	4-M6/4-M5	φ14/φ19	42	φ73	6	90	91.5
	φ90	4-M5/4-M6	φ19	42	φ70	6	90	91.5
	φ115	4-M8	φ19/φ22	54	φ95	8	110	103.5
	φ130	4-M8	φ19/φ22	54	φ95	8	110	103.5
	φ145	4-M8	φ19/φ22	57.5	φ110	8	130	107

外形尺寸图表
Outline dimensional

ZAF115-L1[Single]

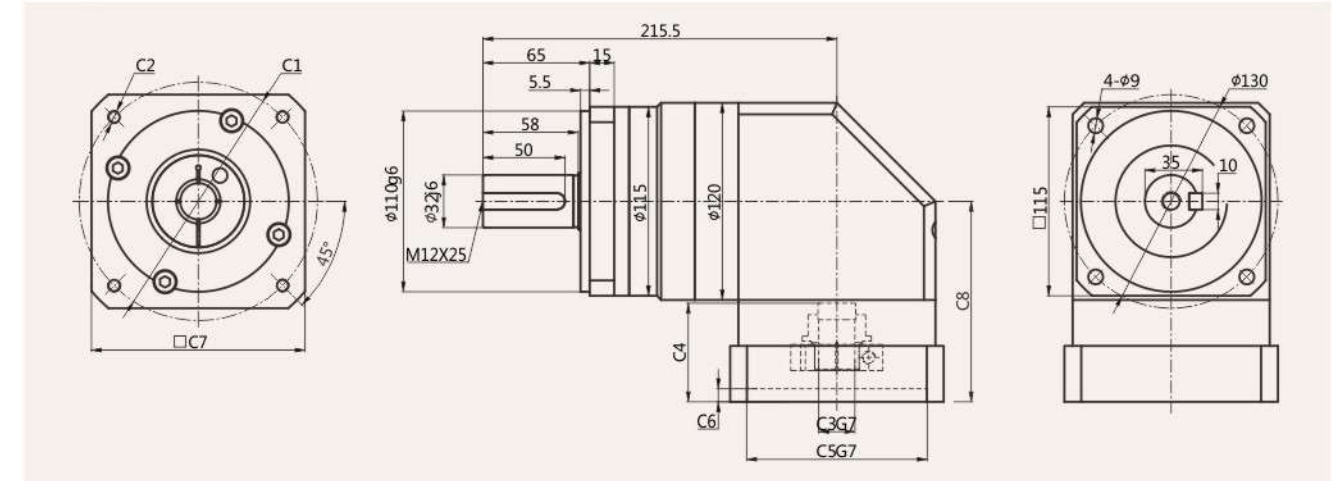

ZAF115-L2[Double]

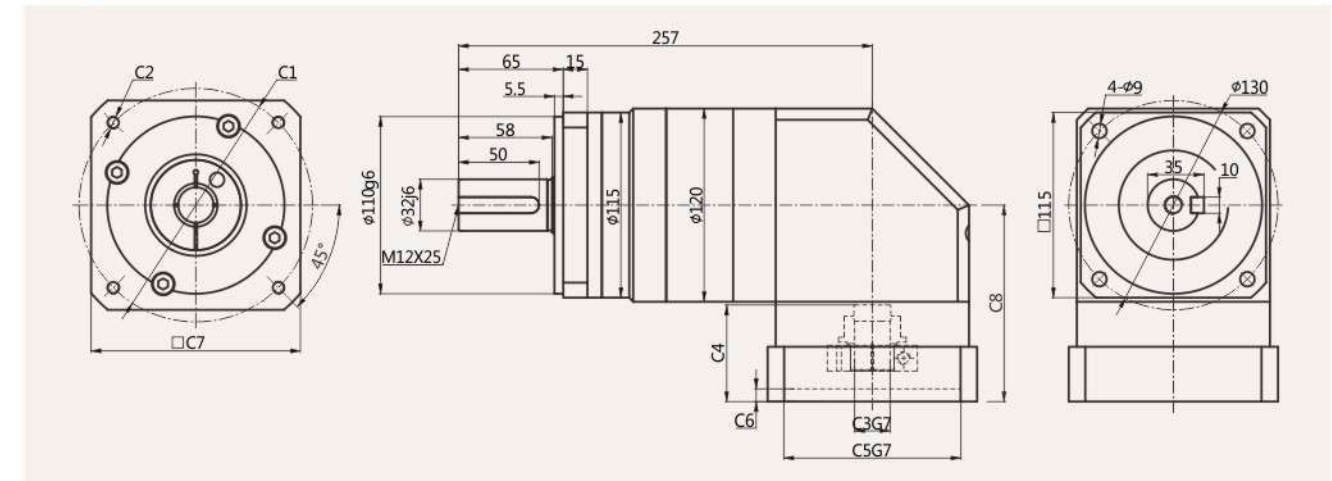

适配电机输入接口尺寸(左端为输入尺寸)
Adapter motor input interface size (The left end is the input size)

尺寸 Size	C1	C2	C3	C4	C5	C6	C7	C8
ZAF-115-L1	φ115	4-M8/4-M6	φ22/φ24	57	φ95	8	130	119
	φ130	4-M8	φ22/φ24	57	φ95	8	130	119
	φ145	4-M8	φ22/φ24	60	φ110	8	130	122
ZAF-115-L2	φ115	4-M8/4-M6	φ22/φ24	57	φ95	8	130	119
	φ130	4-M8	φ22/φ24	57	φ95	8	130	119
	φ145	4-M8	φ22/φ24	60	φ110	8	130	122

ZAF Series

外形尺寸图表
Outline dimensional

ZAF140-L1[Single]

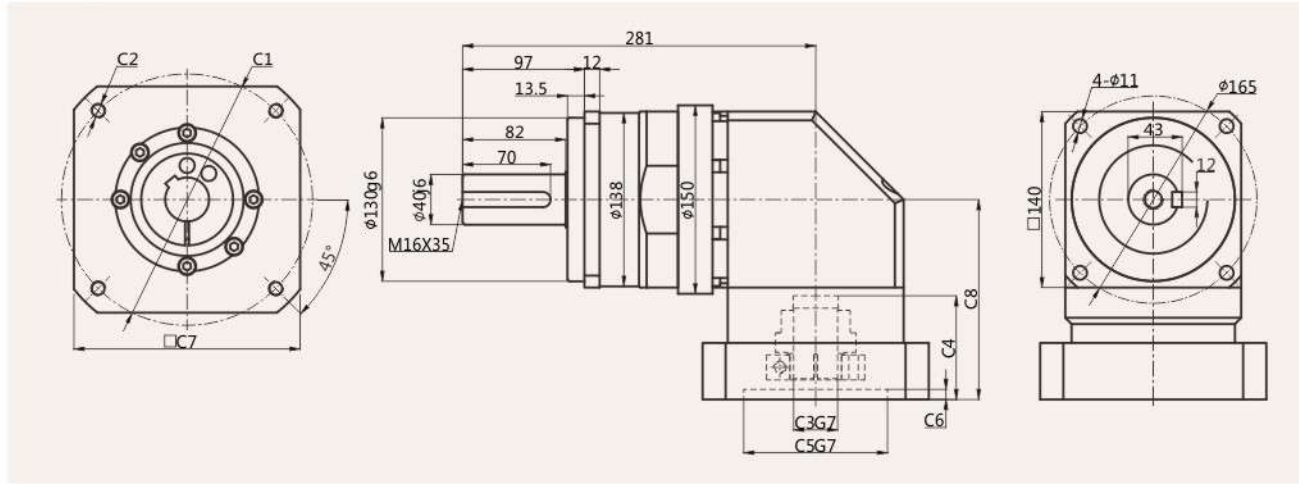

ZAF140-L2[Double]

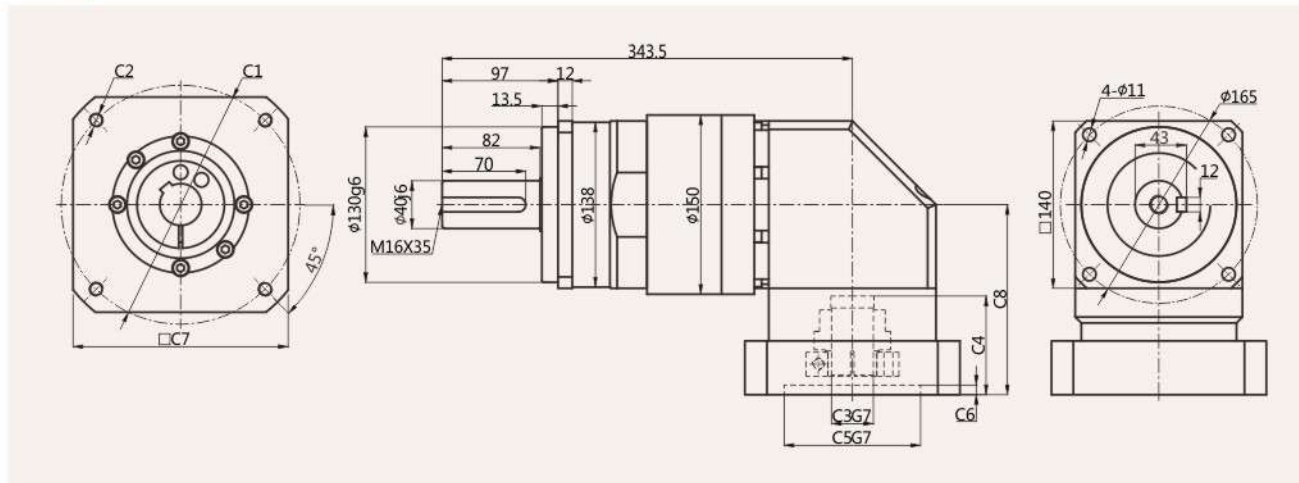

适配电机输入接口尺寸(左端为输入尺寸)
Adapter motor input interface size (The left end is the input size)

尺寸 Size	C1	C2	C3	C4	C5	C6	C7	C8
ZAF-140-L1	Φ115	4-M8/M6	Φ22/Φ24	67.5	Φ95	8	115	144
	Φ145	4-M8	Φ22/Φ24	72.5	Φ110	8	130	149
	Φ200	4-M12	Φ35/Φ42	82.5	Φ114.3	8	180	159
	Φ200	4-M12	Φ35/Φ42	117	Φ114.3	8	180	191.5
	Φ215	4-M12	Φ42	87.5	Φ180	8	200	164
ZAF-140-L2	Φ115	4-M8/M6	Φ22/Φ24	67.5	Φ95	8	115	144
	Φ145	4-M8	Φ22/Φ24	72.5	Φ110	8	130	149
	Φ200	4-M12	Φ35/Φ42	82.5	Φ114.3	8	180	159
	Φ200	4-M12	Φ35/Φ42	117	Φ114.3	8	180	191.5
	Φ200	4-M12	Φ35/Φ42	117	Φ114.3	8	180	191.5

外形尺寸图表
Outline dimensional

ZAF180-L1[Single]

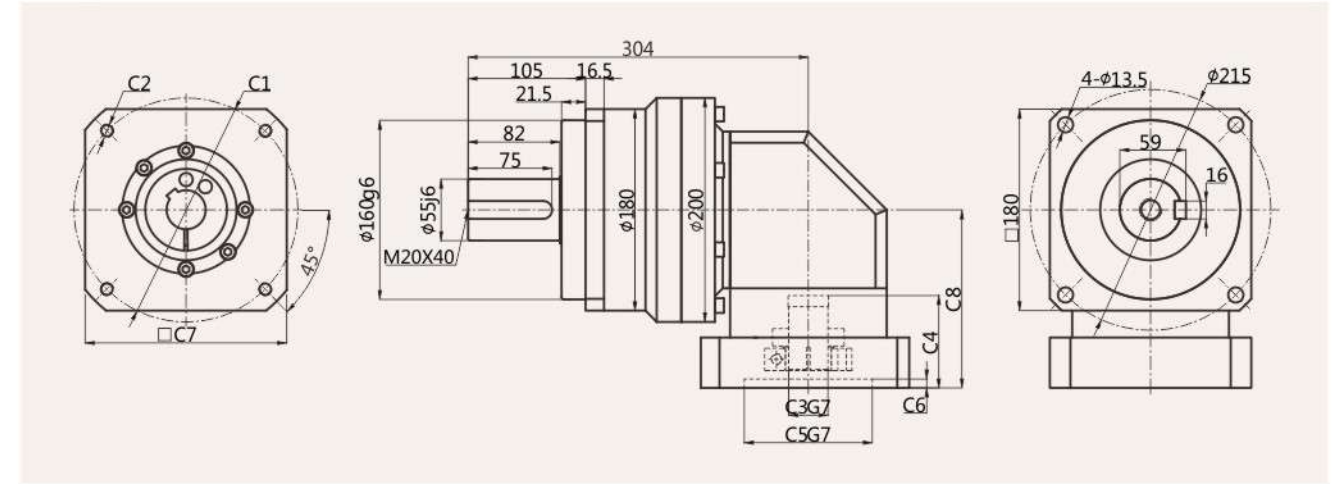

ZAF180-L2[Double]

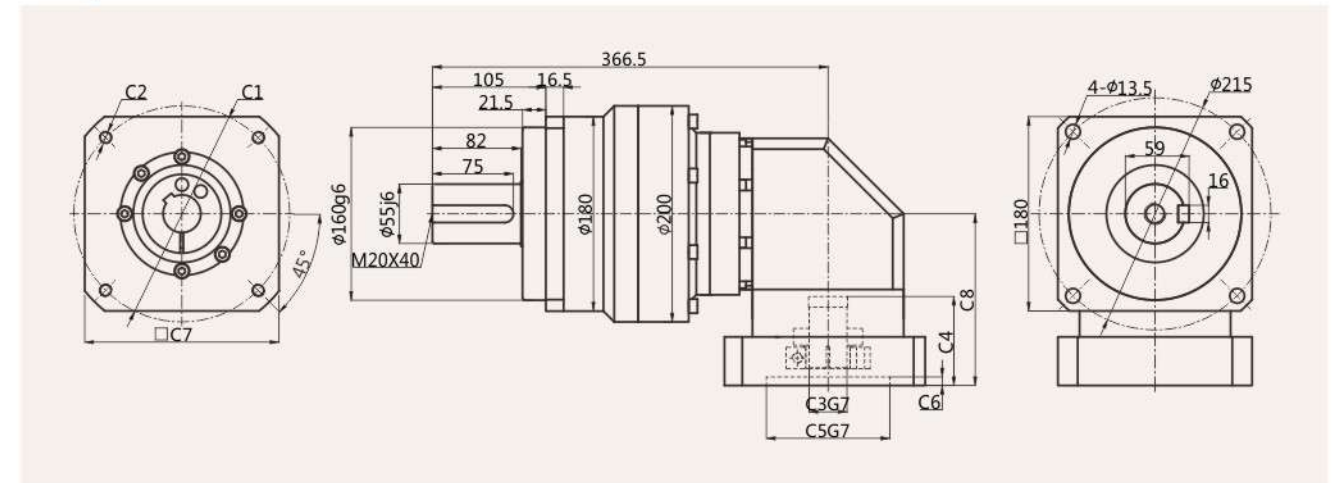

适配电机输入接口尺寸(左端为输入尺寸)
Adapter motor input interface size (The left end is the input size)

尺寸 Size	C1	C2	C3	C4	C5	C6	C7	C8
ZAF-180-L1	Φ200	4-M12	Φ35/Φ42	82.5	Φ114.3	8	180	159
	Φ200	4-M12	Φ35/Φ42	117	Φ114.3	8	180	191.5
	Φ215	4-M12	Φ42	87.5	Φ180	8	200	164
	Φ115	4-M8/M6	Φ22/Φ24	67.5	Φ95	8	115	144
ZAF-180-L2	Φ145	4-M8	Φ22/Φ24	72.5	Φ110	8	130	149
	Φ200	4-M12	Φ35/Φ42	82.5	Φ114.3	8	180	159
	Φ200	4-M12	Φ35/Φ42	117	Φ114.3	8	180	191.5
	Φ215	4-M12	Φ42	87.5	Φ180	8	200	164

- ✓ ZAL070
- ✓ ZAL090
- ✓ ZAL120
- ✓ ZAL155
- ✓ ZAL205

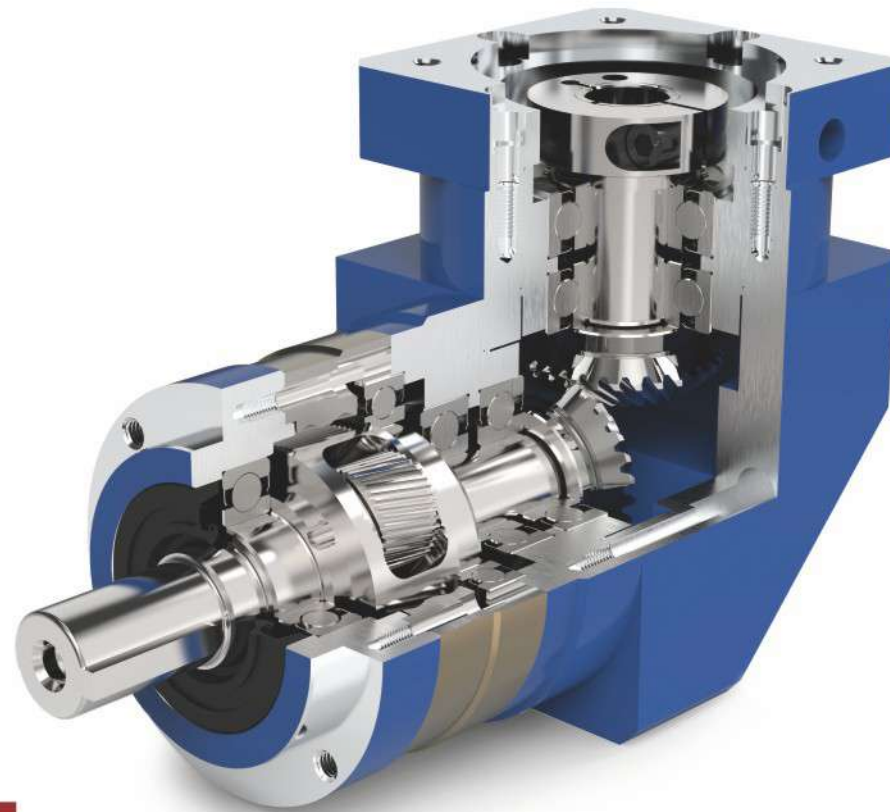

ZAL Series

ZAL系列减速机核心特性

The Core Characteristics of ZAL Series Reducer

- 1 采用斜齿齿轮传动，经渗碳淬火处理，齿向齿廓修形处理，确保运行低噪音、平稳；承载能力较直齿提高20%；
- 2 整体式输出轴，行星轮两端轴承支撑，实现高精度、强度；
- 3 伞齿轮采用磨齿工艺精度可达6级，确保运行低噪音、平稳；
- 4 回程间隙小，精密型单级可以做到5arcmin以内。

- 1 Helical gear transmission, carburizing and quenching treatment, tooth profile modification treatment, to ensure low noise and smooth operation. The bearing capacity is 20% higher than that of straight teeth.
- 2 Integral output shaft and bearing support at both ends of planetary wheel to achieve high precision and strength to ensure low noise and smooth operation.
- 3 The bevel gear adopts gear grinding technology, and the accuracy grade can reach grade 6.
- 4 The backlash clearance is small, and the precision single stage can achieve less than 5 arcmin.

减速机性能资料

Gear box performance information

型号 Model	单位 Unit	ZAL070	ZAL090	ZAL120	ZAL155	ZAL205	减速比 Ratio	Stage
额定输出扭矩 Rated output torque	N·m	35	100	230	450	1000	3	1
		45	110	270	580	1300	4	
		44	105	255	540	1100	5	
		40	100	180	390	800	7	
		22	50	120	230	460	10	
		35	100	230	450	1000	15	
		45	110	270	580	1300	16	
		45	110	270	580	1300	20	
		44	105	255	540	1100	25	
		45	110	270	580	1300	28	
		35	100	230	450	1000	30	
		44	105	255	540	1100	35	
		45	110	270	580	1300	40	
		44	105	255	540	1100	50	
40	100	180	390	800	70			
22	50	120	230	460	100			
故障停滞扭矩 Emergency stop torque	N·m	3倍额定输出扭矩 3 times Rated output torque						
额定输入转速 Norminal input speed	rpm	3000	3000	3000	2000	1500		
额定输入转速 Maximum input speed	rpm	6000	6000	6000	4000	3000		
最大径向力 ¹⁾ Maximum radial force	N	920	1400	3000	5800	9500		
最大轴向力 ¹⁾ Maximum axial force	N	630	600	2500	4500	6800		
效率 Efficiency	%	Single [95%]			Double [93%]			
平均寿命 Average lifetime	h	20000						
重量 (大概) Weight	kg	2.1	5.6	11	24	39		1
		2.6	6.6	14	30	45		2
转动惯量 Moment of inertia	kgcm ²	0.39	2.45	6.7	27	44	3	1
		0.34	2.22	5.4	22	28	4	
		0.32	2.13	5	21	22	5	
		0.31	2.06	4.6	19	16	7	
		0.3	2.02	4.4	19	14	10	
		0.11	0.6	0.8	15	12	15	
		0.12	0.65	0.9	15	13	16	
		0.11	0.59	0.8	14	12	20	
		0.11	0.59	0.8	14	12	25	
		0.12	0.64	0.8	15	13	28	
		0.10	0.51	0.7	13	11	30	
		0.11	0.59	0.8	14	12	35	
		0.10	0.51	0.7	13	11	40	
		0.10	0.51	0.7	13	11	50	
0.10	0.51	0.7	13	11	70			
0.10	0.51	0.7	13	11	100			
回程间隙 Backlash	arcmin	≤7	≤7	≤7	≤10	≤10		Precise[1]
		≤10	≤10	≤10	≤12	≤12		Standard[1]
		≤10	≤10	≤10	≤12	≤12		Precise[2]
		≤12	≤12	≤12	≤14	≤14		Standard[2]
抗扭刚性 Torsional rigidity	N·m/arc min	7	14	25	50	145		
噪音 Noise	dB	65	65	68	70	75		
润滑 lubricating		合成油脂润滑 Synthetic grease lubrication						
防护等级 levels of protection		IP65						

※1 输出转速为100rpm时，作用于输出轴中心位置

外形尺寸图表
Outline dimensional

ZAL070-L1[Single]

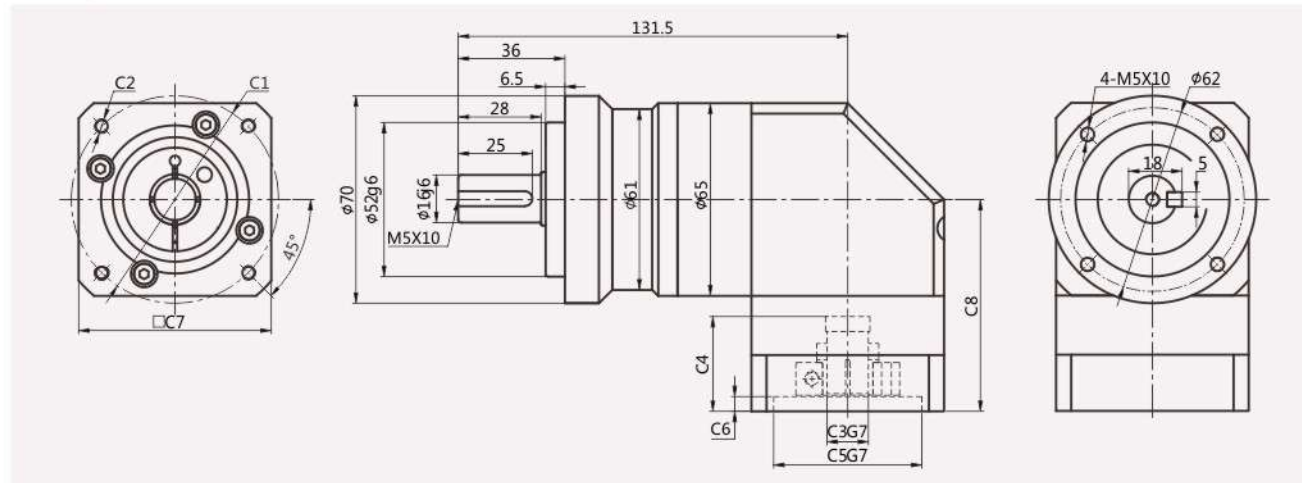

ZAL070-L2[Double]

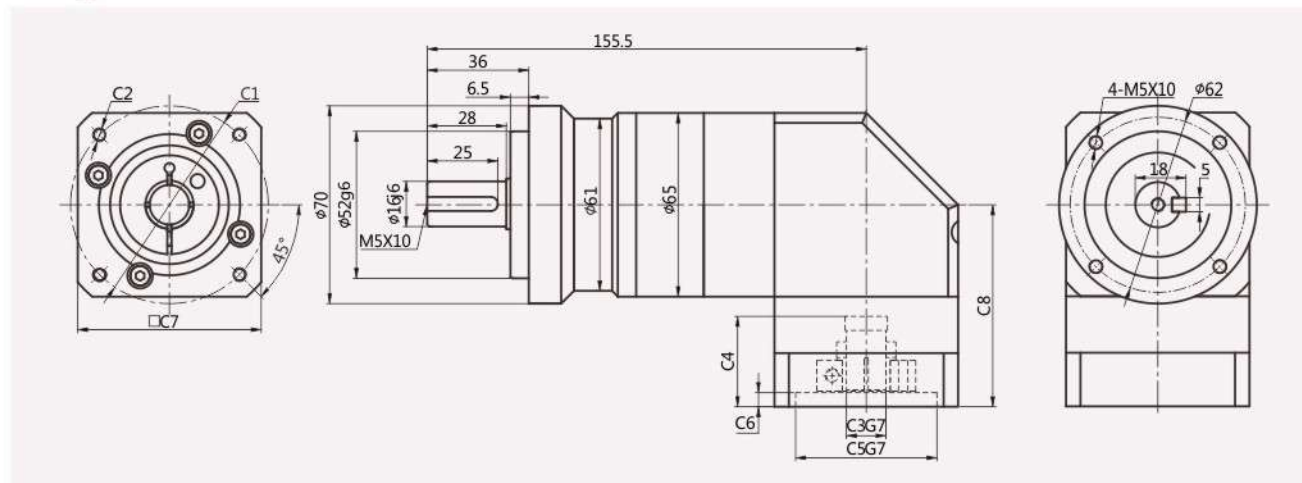

适配电机输入接口尺寸(左端为输入尺寸)
Adapter motor input interface size (The left end is the input size)

尺寸 Size	C1	C2	C3	C4	C5	C6	C7	C8
ZAL-070-L1	Φ70	4-M4/4-M5	Φ14	32	Φ50	5	65	71.5
ZAL-070-L2	Φ70	4-M4/4-M5	Φ14	32	Φ50	5	65	71.5

外形尺寸图表
Outline dimensional

ZAL090-L1[Single]

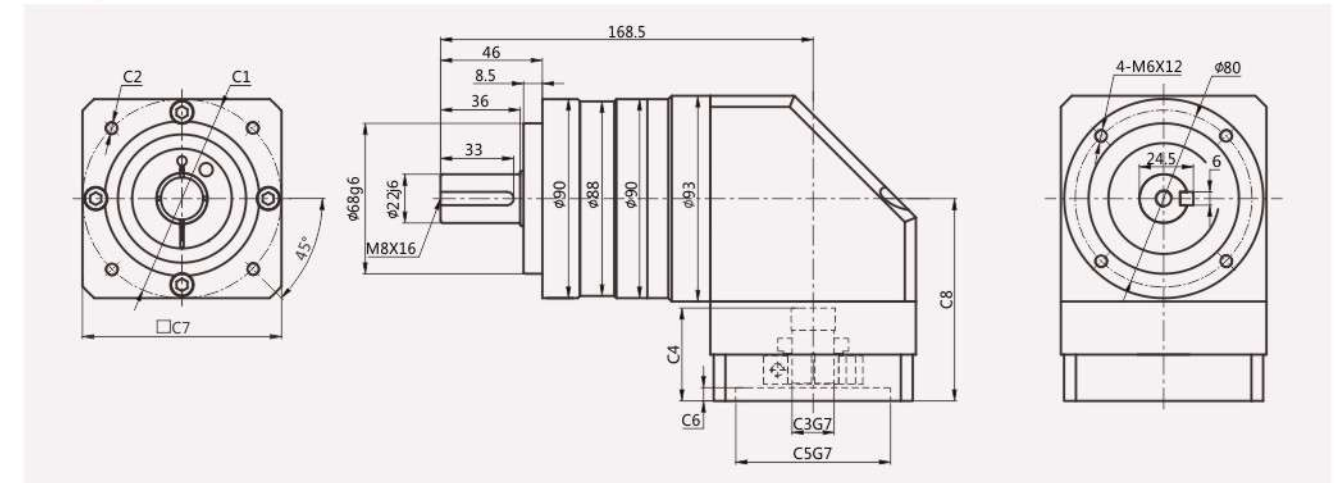

ZAL090-L2[Double]

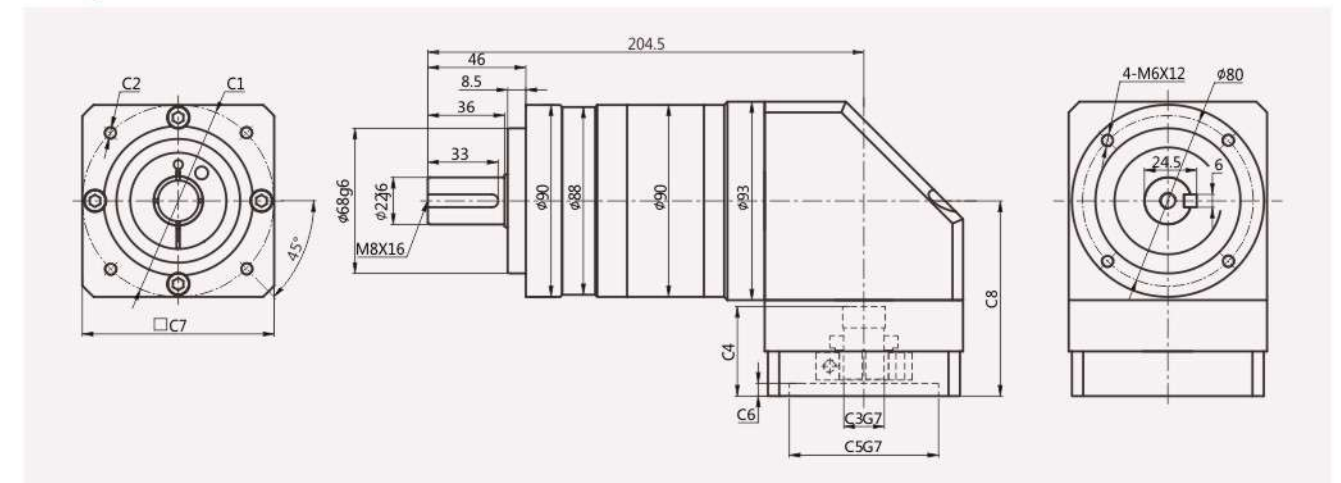

适配电机输入接口尺寸(左端为输入尺寸)
Adapter motor input interface size (The left end is the input size)

尺寸 Size	C1	C2	C3	C4	C5	C6	C7	C8
ZAL-090-L1	Φ98.4	4-M6/4-M5	Φ14/Φ19	42	Φ73	6	90	91.5
	Φ90	4-M5/4-M6	Φ19	42	Φ70	6	90	91.5
	Φ115	4-M8	Φ19/Φ22	54	Φ95	8	110	103.5
	Φ130	4-M8	Φ19/Φ22	54	Φ95	8	110	103.5
ZAL-090-L2	Φ145	4-M8	Φ19/Φ22	57.5	Φ110	8	130	107
	Φ98.4	4-M6/4-M5	Φ14/Φ19	42	Φ73	6	90	91.5
	Φ90	4-M5/4-M6	Φ19	42	Φ70	6	90	91.5
	Φ115	4-M8	Φ19/Φ22	54	Φ95	8	110	103.5

外形尺寸图表
Outline dimensional

ZAL120-L1[Single]

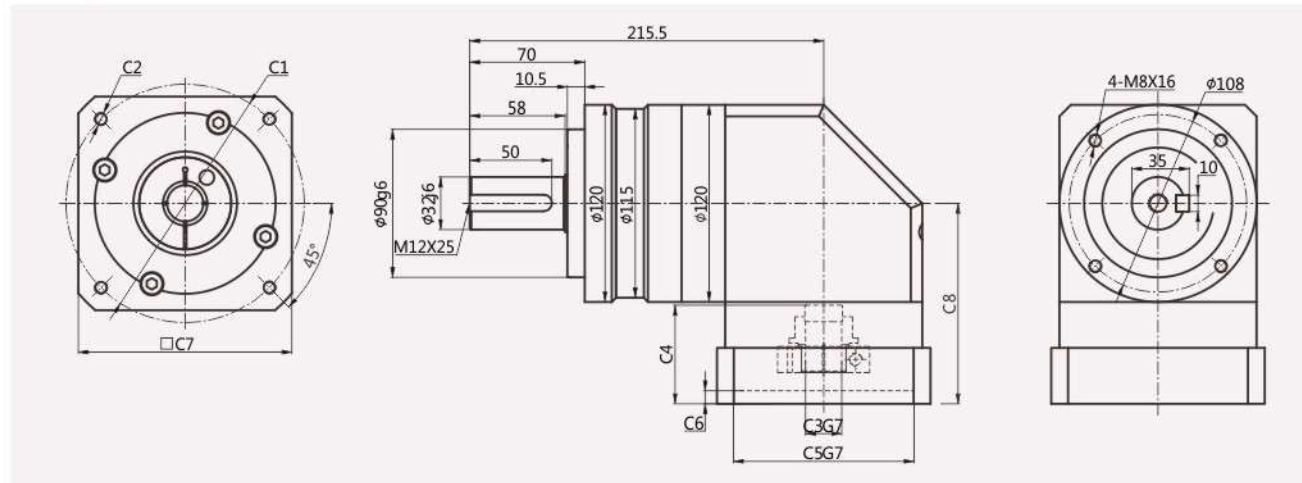

ZAL120-L2[Double]

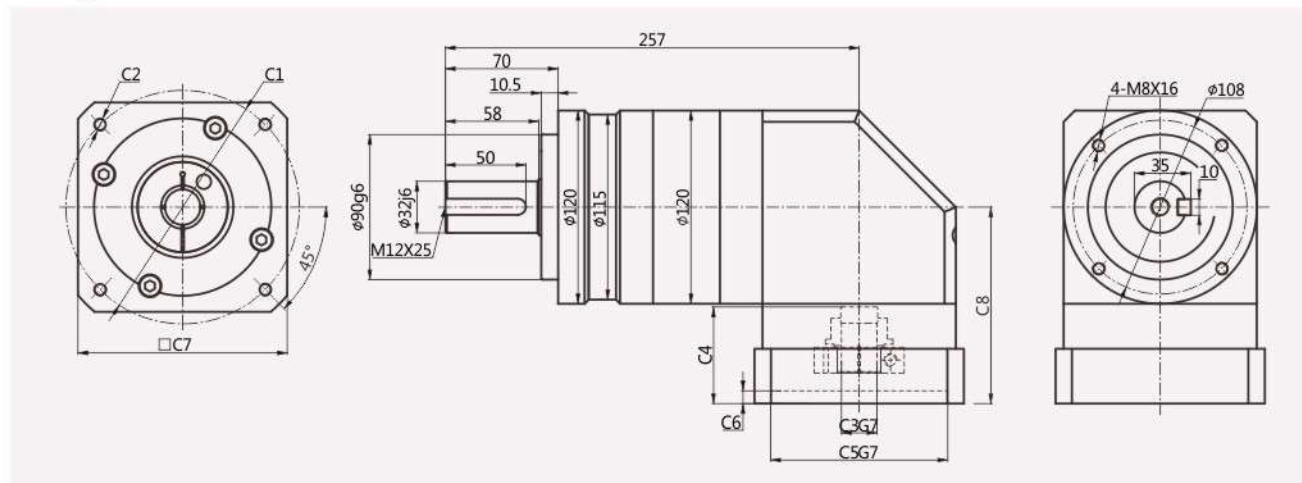

适配电机输入接口尺寸(左端为输入尺寸)
Adapter motor input interface size (The left end is the input size)

尺寸 Size	C1	C2	C3	C4	C5	C6	C7	C8
ZAL-120-L1	Φ115	4-M8/4-M6	Φ22/Φ24	57	Φ95	8	130	119
	Φ130	4-M8	Φ22/Φ24	57	Φ95	8	130	119
	Φ145	4-M8	Φ22/Φ24	60	Φ110	8	130	122
ZAL-120-L2	Φ115	4-M8/4-M6	Φ22/Φ24	57	Φ95	8	130	119
	Φ130	4-M8	Φ22/Φ24	57	Φ95	8	130	119
	Φ145	4-M8	Φ22/Φ24	60	Φ110	8	130	122

外形尺寸图表
Outline dimensional

ZAL155-L1[Single]

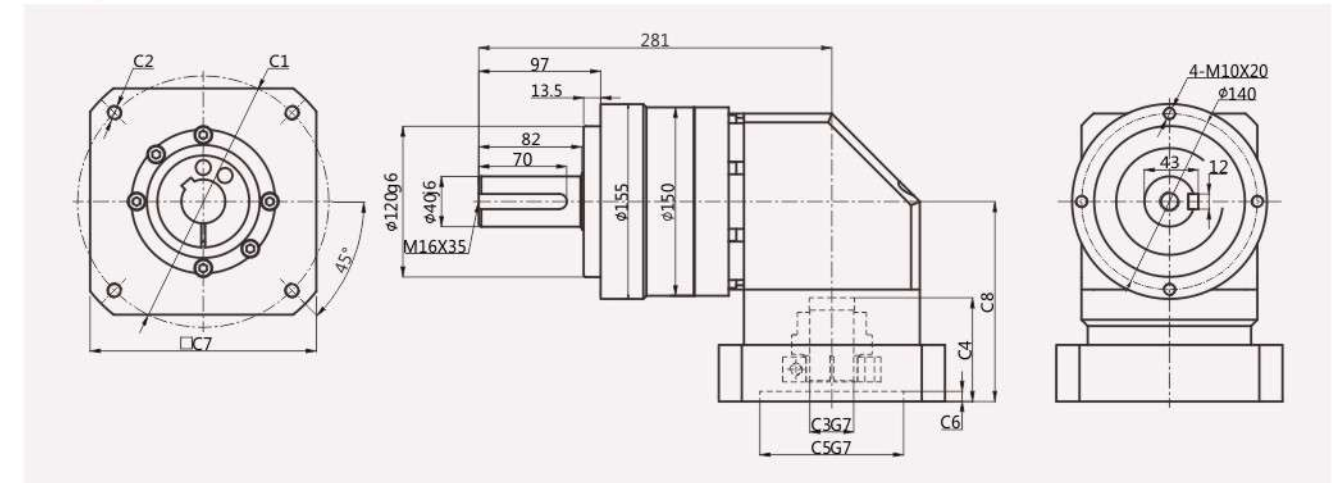

ZAL155-L2[Double]

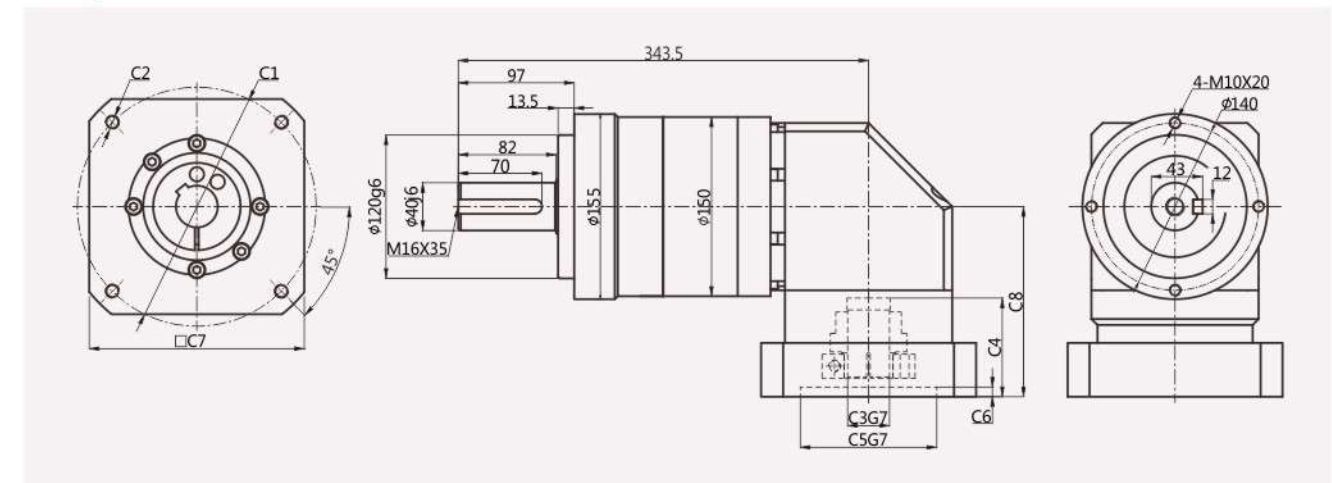

适配电机输入接口尺寸(左端为输入尺寸)
Adapter motor input interface size (The left end is the input size)

尺寸 Size	C1	C2	C3	C4	C5	C6	C7	C8
ZAL-155-L1	Φ115	4-M8/M6	Φ22/Φ24	67.5	Φ95	8	115	144
	Φ145	4-M8	Φ22/Φ24	72.5	Φ110	8	130	149
	Φ200	4-M12	Φ35/Φ42	82.5	Φ114.3	8	180	159
	Φ200	4-M12	Φ35/Φ42	117	Φ114.3	8	180	191.5
ZAL-155-L2	Φ115	4-M8/M6	Φ22/Φ24	67.5	Φ95	8	115	144
	Φ145	4-M8	Φ22/Φ24	72.5	Φ110	8	130	149
	Φ200	4-M12	Φ35/Φ42	82.5	Φ114.3	8	180	159
	Φ200	4-M12	Φ35/Φ42	117	Φ114.3	8	180	191.5

外形尺寸图表 Outline dimensional

ZAL205-L1[Single]

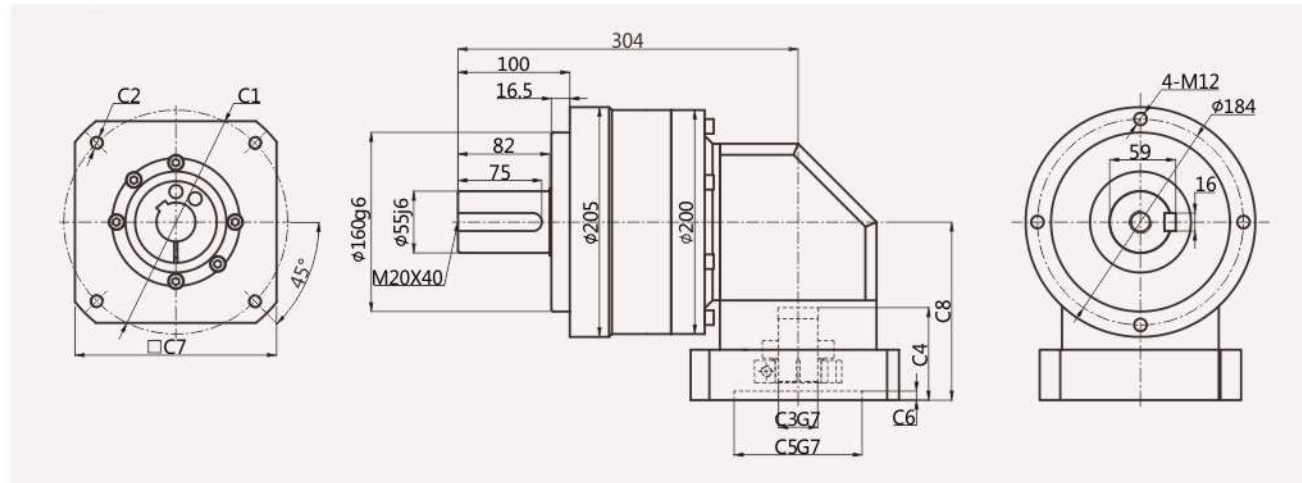

ZAL205-L2[Double]

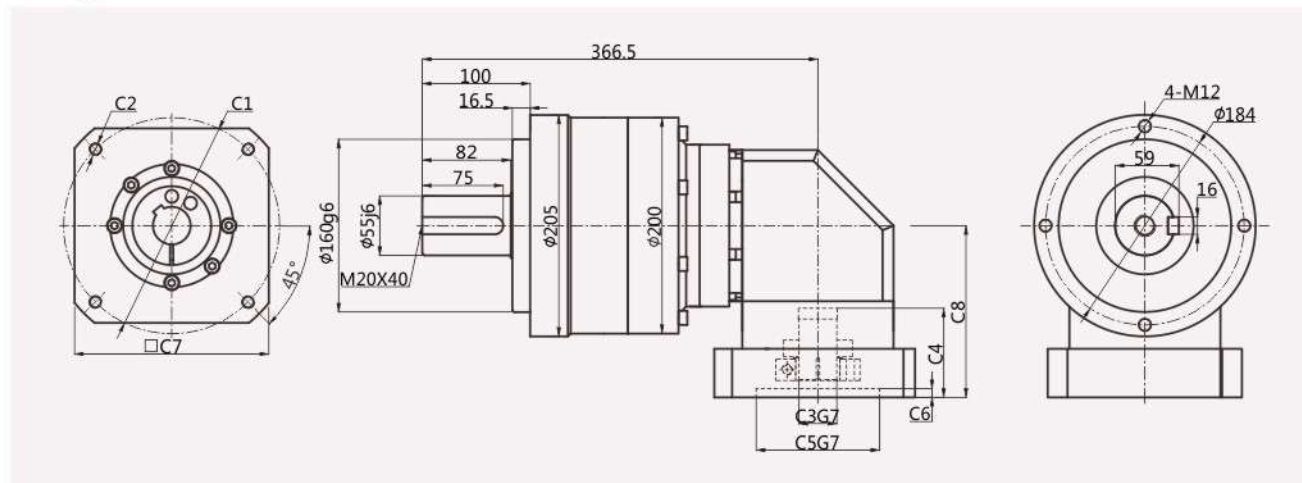

适配电机输入接口尺寸(左端为输入尺寸)
Adapter motor input interface size (The left end is the input size)

尺寸 Size	C1	C2	C3	C4	C5	C6	C7	C8
ZAL-205-L1	Φ200	4-M12	Φ35/Φ42	82.5	Φ114.3	8	180	159
	Φ200	4-M12	Φ35/Φ42	117	Φ114.3	8	180	191.5
	Φ215	4-M12	Φ42	87.5	Φ180	8	200	164
ZAL-205-L2	Φ115	4-M8/M6	Φ22/Φ24	67.5	Φ95	8	115	144
	Φ145	4-M8	Φ22/Φ24	72.5	Φ110	8	130	149
	Φ200	4-M12	Φ35/Φ42	82.5	Φ114.3	8	180	159
	Φ200	4-M12	Φ35/Φ42	117	Φ114.3	8	180	191.5
	Φ215	4-M12	Φ42	87.5	Φ180	8	200	164

- ✓ ZAH064
- ✓ ZAGH090
- ✓ ZAGH110
- ✓ ZAGH140
- ✓ ZAGH200

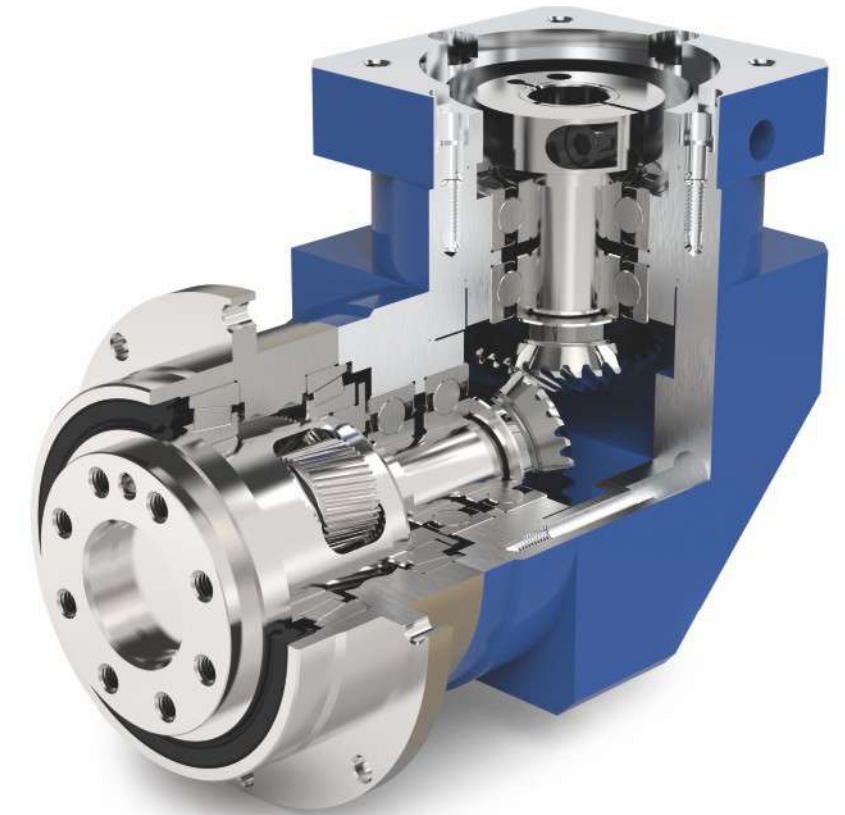

ZAGH Series

ZAGH系列减速机核心特性
The Core Characteristics of ZAGH Series Reducer

- 1 采用斜齿齿轮传动，经渗碳淬火处理，齿向齿廓修形处理，确保运行低噪音、平稳，承载能力较直齿提高20%；
- 2 整体式输出轴，行星轮两端轴承支撑，实现高精度、强度；
- 3 内齿圈采用整体式结构设计；
- 4 前后大跨度圆锥滚子轴承排列，超强径向和轴向承载能力（ZAH064除外）；
- 5 伞齿轮采用磨齿工艺精度可达6级，确保运行低噪音、平稳；
- 6 回程间隙小，精密型单级可以做到5arcmin以内。

- 1 Helical gear transmission, carburizing and quenching treatment, tooth profile modification treatment, to ensure low noise and smooth operation. The bearing capacity is 20% higher than that of straight teeth.
- 2 Integral output shaft and bearing support at both ends of planetary wheel to achieve high precision and strength.
- 3 The inner gear ring adopts integral structure design.
- 4 Arrangement of front and rear large span tapered roller bearings Super strong radial and axial bearing capacity(Except ZAH064 Series).
- 5 The bevel gear adopts gear grinding technology, and the accuracy grade can reach grade 6.
- 6 The backlash clearance is small, and the precision single stage can achieve less than 5 arcmin.

减速机性能资料 Gear box performance information

型号 Model	单位 Unit	ZAH064	ZAGH090	ZAGH110	ZAGH140	ZAGH200	减速比 Ratio	Stage
额定输出扭矩 Rated output torque	N·m	45	150	270	580	1300	4	1
		44	140	255	540	1100	5	
		40	100	180	390	800	7	
		22	50	120	230	460	10	
		45	150	270	580	1300	16	2
		45	150	270	580	1300	20	
		44	140	255	540	1100	25	
		45	150	270	580	1300	28	
		44	140	255	540	1100	35	
		45	150	270	580	1300	40	
		44	140	255	540	1100	50	
		40	100	180	390	800	70	
		22	50	120	230	460	100	
		故障停滞扭矩 Emergency stop torque	N·m	3倍额定输出扭矩 3 times Rated output torque				
额定输入转速 Norminal input speed	rpm	3000	3000	3000	2000	1500		
额定输入转速 Maximum input speed	rpm	6000	6000	6000	4000	3000		
最大径向力 ^{※1} Maximum radial force	N	550	4000	7800	10000	16000		
最大轴向力 ^{※1} Maximum axial force	N	375	3000	7000	8000	13000		
效率 Efficiency	%	Single [95%]			Double [93%]			
平均寿命 Average lifetime	h	20000						
重量 (大概) Weight	kg	2.3	6.1	12	24	43		1
		2.8	7.4	15	30	49		2
转动惯量 Moment of inertia	kgcm ²	0.34	2.22	5.4	22	28	4	1
		0.32	2.13	5	21	22	5	
		0.31	2.06	4.6	19	16	7	
		0.3	2.02	4.4	19	14	10	
		0.12	0.65	2.7	15	13	16	2
		0.11	0.59	2.5	14	12	20	
		0.11	0.59	2.5	14	12	25	
		0.12	0.64	2.7	15	13	28	
		0.11	0.59	2.1	14	12	35	
		0.10	0.51	2.1	13	11	40	
		0.10	0.51	2.1	13	11	50	
		0.10	0.51	2.1	13	11	70	
		0.10	0.51	2.1	13	11	100	
		回程间隙 Backlash	arcmin	≤7	≤7	≤7	≤10	≤10
≤10	≤10			≤10	≤12	≤12		Standard[1]
≤10	≤10			≤10	≤12	≤12		Precise[2]
≤12	≤12			≤12	≤14	≤14		Standard[2]
抗扭刚性 Torsional rigidity	N·m/arc min	7	14	25	50	145		
噪音 Noise	dB	65	65	68	70	75		
润滑 lubricating		合成油脂润滑 Synthetic grease lubrication						
防护等级 levels of protection		IP65						

※1 输出转速为100rpm时，作用于输出轴中心位置

外形尺寸图表 Outline dimensional

ZAH064-L1[Single]

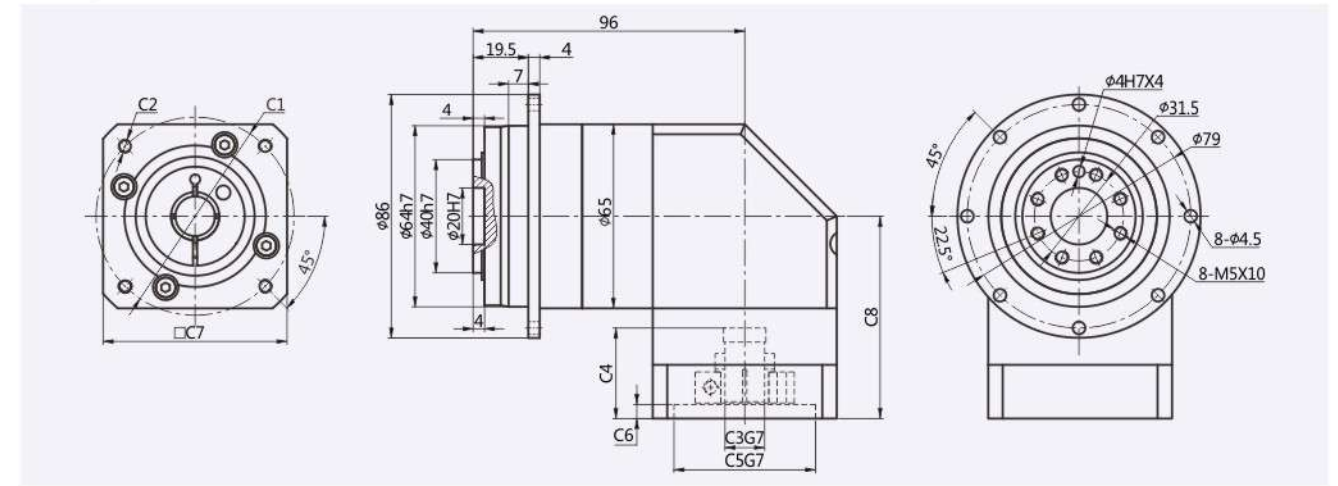

ZAH064-L2[Double]

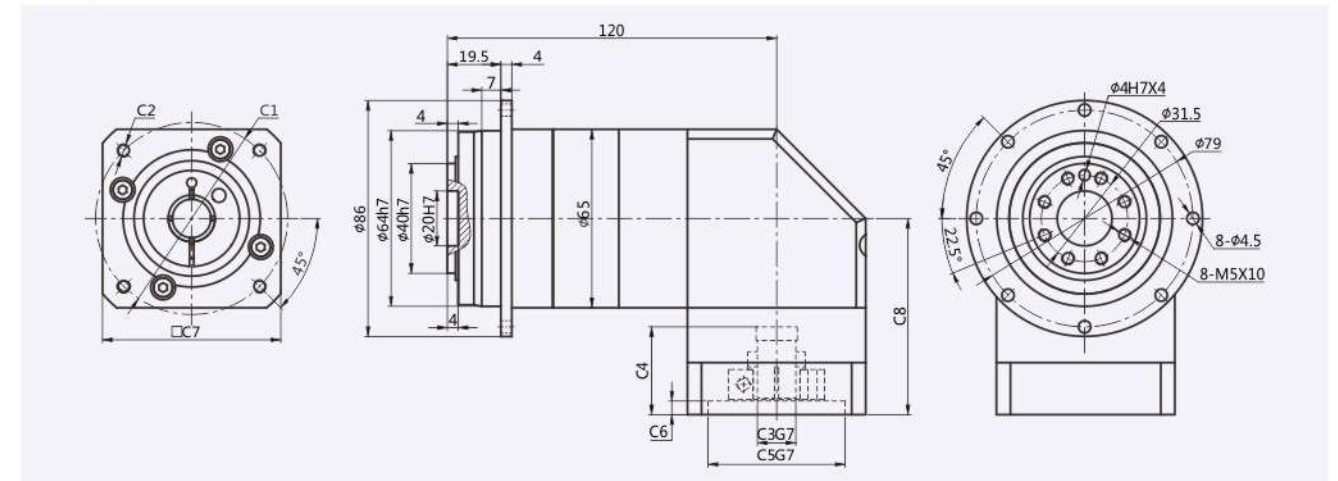

适配电机输入接口尺寸(左端为输入尺寸)
Adapter motor input interface size (The left end is the input size)

尺寸 Size	C1	C2	C3	C4	C5	C6	C7	C8
ZAH-064-L1	$\phi 70$	4-M4/4-M5	$\phi 14$	32	$\phi 50$	5	65	71.5
ZAH-064-L2	$\phi 70$	4-M4/4-M5	$\phi 14$	32	$\phi 50$	5	65	71.5

外形尺寸图表
Outline dimensional

ZAGH090-L1[Single]

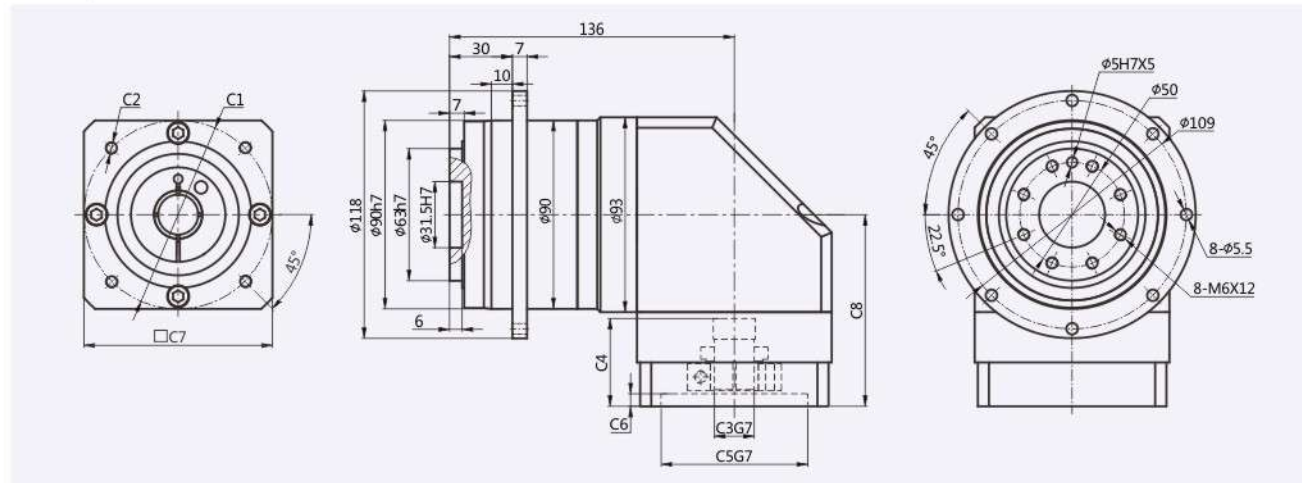

ZAGH090-L2[Double]

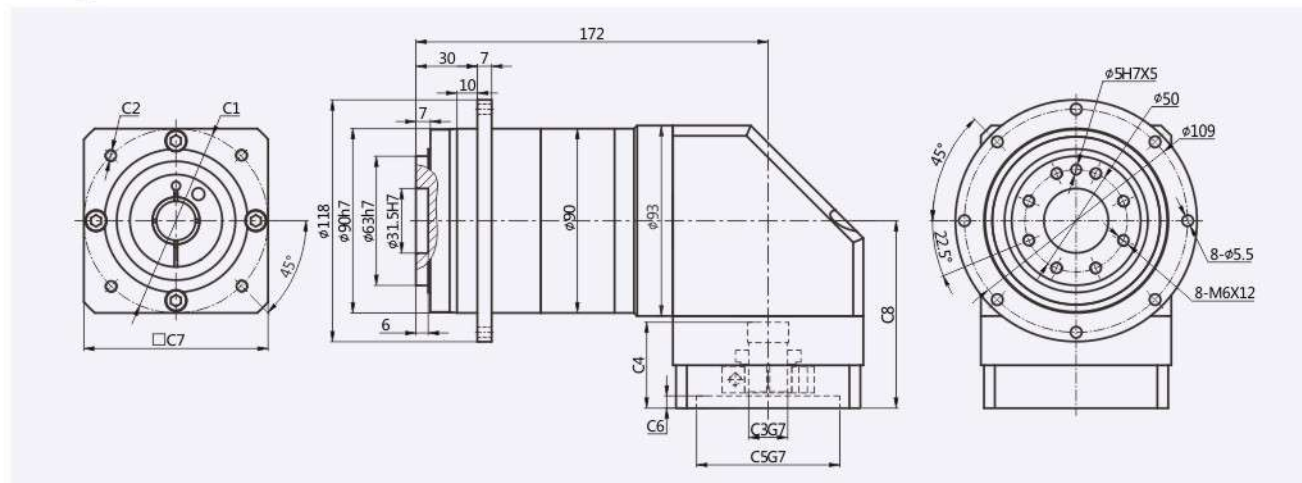

适配电机输入接口尺寸(左端为输入尺寸)
Adapter motor input interface size (The left end is the input size)

尺寸 Size	C1	C2	C3	C4	C5	C6	C7	C8
ZAGH-090-L1	Φ98.4	4-M6/4-M5	Φ14/Φ19	42	Φ73	6	90	91.5
	Φ90	4-M5/4-M6	Φ19	42	Φ70	6	90	91.5
	Φ115	4-M8	Φ19/Φ22	54	Φ95	8	110	103.5
	Φ130	4-M8	Φ19/Φ22	54	Φ95	8	110	103.5
	Φ145	4-M8	Φ19/Φ22	57.5	Φ110	8	130	107
ZAGH-090-L2	Φ98.4	4-M6/4-M5	Φ14/Φ19	42	Φ73	6	90	91.5
	Φ90	4-M5/4-M6	Φ19	42	Φ70	6	90	91.5
	Φ115	4-M8	Φ19/Φ22	54	Φ95	8	110	103.5
	Φ130	4-M8	Φ19/Φ22	54	Φ95	8	110	103.5
	Φ145	4-M8	Φ19/Φ22	57.5	Φ110	8	130	107

外形尺寸图表
Outline dimensional

ZAGH110-L1[Single]

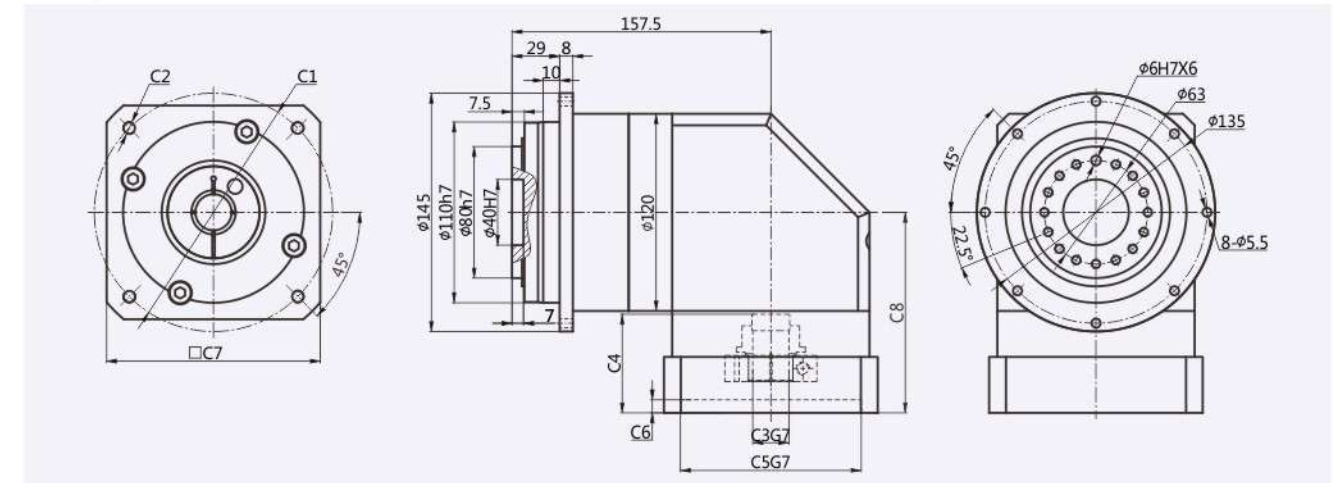

ZAGH110-L2[Double]

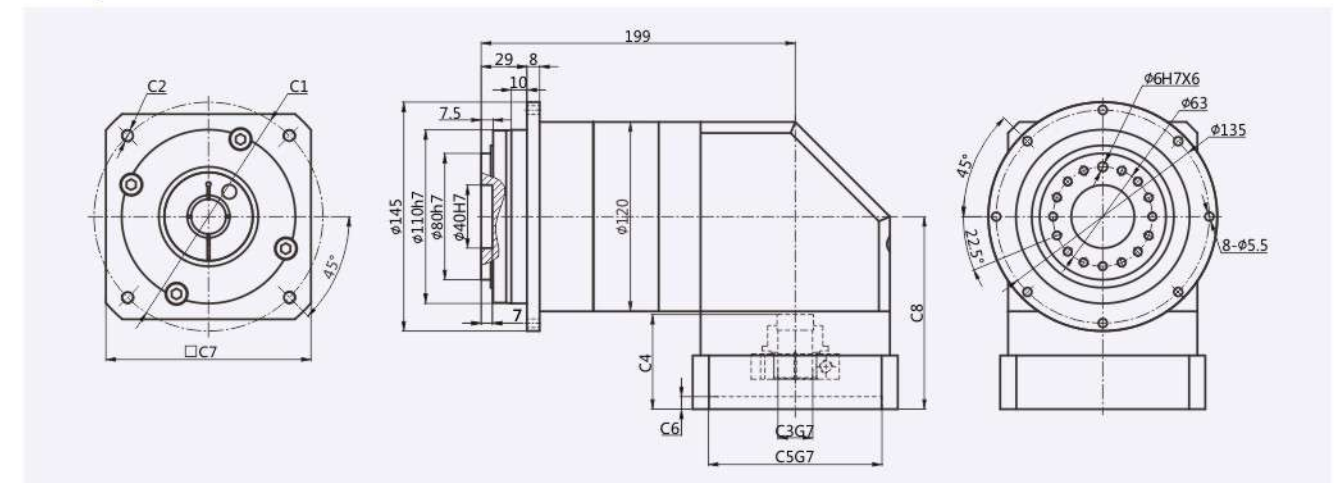

适配电机输入接口尺寸(左端为输入尺寸)
Adapter motor input interface size (The left end is the input size)

尺寸 Size	C1	C2	C3	C4	C5	C6	C7	C8
ZAGH-110-L1	Φ115	4-M8/4-M6	Φ22/Φ24	57	Φ95	8	130	119
	Φ130	4-M8	Φ22/Φ24	57	Φ95	8	130	119
	Φ145	4-M8	Φ22/Φ24	60	Φ110	8	130	122
ZAGH-110-L2	Φ115	4-M8/4-M6	Φ22/Φ24	57	Φ95	8	130	119
	Φ130	4-M8	Φ22/Φ24	57	Φ95	8	130	119
	Φ145	4-M8	Φ22/Φ24	60	Φ110	8	130	122

外形尺寸图表
Outline dimensional

ZAGH140-L1[Single]

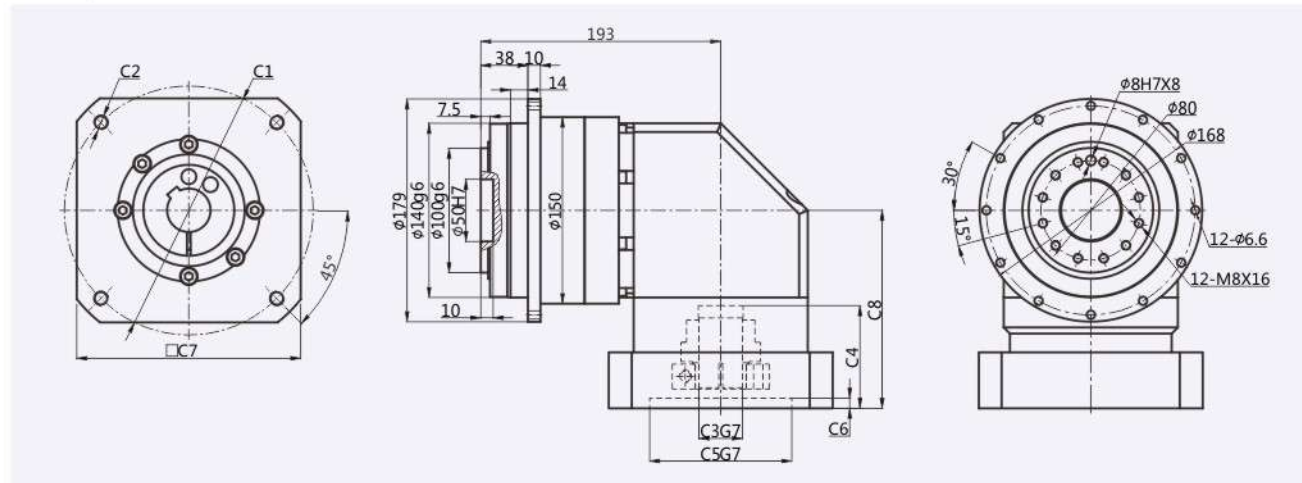

ZAGH140-L2[Double]

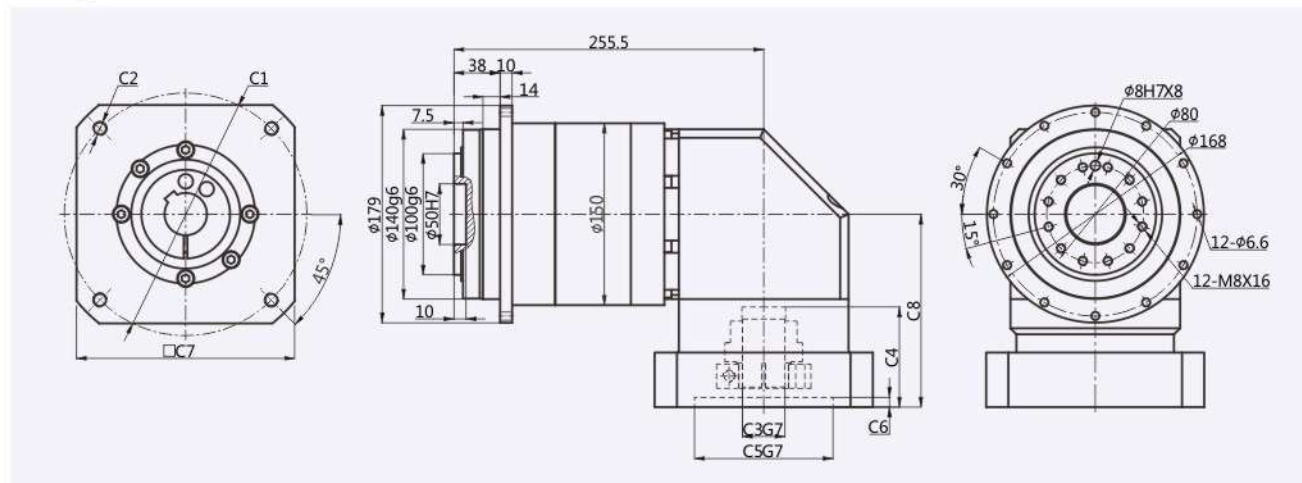

适配电机输入接口尺寸(左端为输入尺寸)
Adapter motor input interface size (The left end is the input size)

尺寸 Size	C1	C2	C3	C4	C5	C6	C7	C8
ZAGH-140-L1	Φ115	4-M8/M6	Φ22/Φ24	67.5	Φ95	8	115	144
	Φ145	4-M8	Φ22/Φ24	72.5	Φ110	8	130	149
	Φ200	4-M12	Φ35/Φ42	82.5	Φ114.3	8	180	159
	Φ200	4-M12	Φ35/Φ42	117	Φ114.3	8	180	191.5
	Φ215	4-M12	Φ42	87.5	Φ180	8	200	164
ZAGH-140-L2	Φ115	4-M8/M6	Φ22/Φ24	67.5	Φ95	8	115	144
	Φ145	4-M8	Φ22/Φ24	72.5	Φ110	8	130	149
	Φ200	4-M12	Φ35/Φ42	82.5	Φ114.3	8	180	159
	Φ200	4-M12	Φ35/Φ42	117	Φ114.3	8	180	191.5
	Φ200	4-M12	Φ35/Φ42	117	Φ114.3	8	180	191.5

外形尺寸图表
Outline dimensional

ZAGH200-L1[Single]

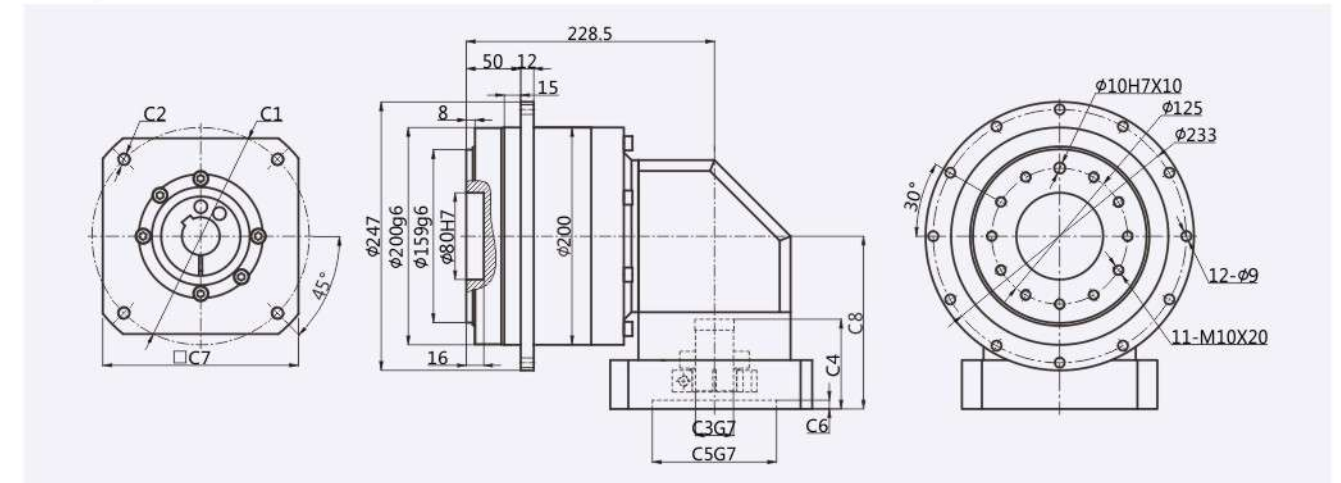

ZAGH200-L2[Double]

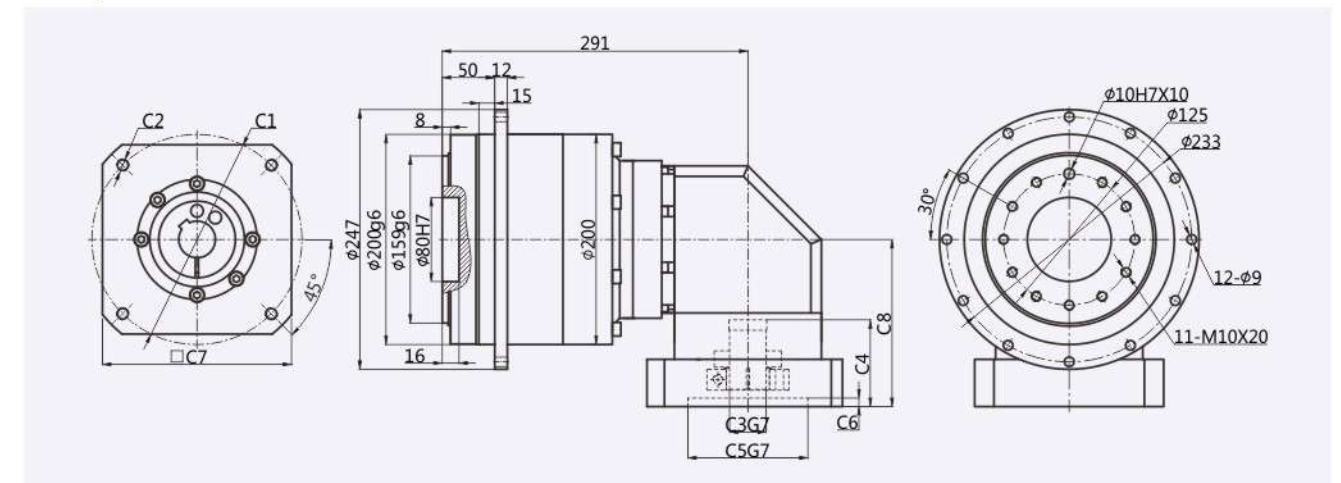

适配电机输入接口尺寸(左端为输入尺寸)
Adapter motor input interface size (The left end is the input size)

尺寸 Size	C1	C2	C3	C4	C5	C6	C7	C8
ZAGH-200-L1	Φ200	4-M12	Φ35/Φ42	82.5	Φ114.3	8	180	159
	Φ200	4-M12	Φ35/Φ42	117	Φ114.3	8	180	191.5
	Φ215	4-M12	Φ42	87.5	Φ180	8	200	164
ZAGH-200-L2	Φ115	4-M8/M6	Φ22/Φ24	67.5	Φ95	8	115	144
	Φ145	4-M8	Φ22/Φ24	72.5	Φ110	8	130	149
	Φ200	4-M12	Φ35/Φ42	82.5	Φ114.3	8	180	159
	Φ215	4-M12	Φ42	87.5	Φ180	8	200	164

Basic Concepts Related to Type Selection

选型相关的基本概念

减速比
Ratio

输入转速/输出转速
Input speed / Output speed

额定输入转速
Rated input speed
 n_1 [rpm]

减速机的驱动速度，若减速机与电机转速相同。本书中的额定输入转速是在环境温度为20℃的条件下测得的。环境温度较高时请降低转速 n_1 。
The drive speed of the reducer is the same as that of the motor. The rated input speed in this book is measured at ambient temperature of 20 degrees Celsius. Reduce speed n_1 at higher ambient temperature.

输出转速
Output speed
 n_2 [rpm]

输出转速按照下列公式通过输入转速 n_1 和传动比 i 计算出来： $n_2=n_1/i$
The output speed is calculated in accordance with the following formula from the input speed n_1 and the transmission ratio i .

段/级数
Poles

行星减速机的套数。由于一套行星减速机无法满足较大的传比，有时需要两套或来满足用户对较大传动比的求，也就是说，减速比越大段/级数越多。由于增加了行星齿轮的数量，所以二级减速机的长度有所增加，效率会有所下降。
The number of Sets of planetary gear. Owing to one set planetary can't satisfy bigger transmission ratio, two sets can meet Users' requirements of bigger transmission ratio, Since increasing the gear quality, the length of the two poles motor will increase accordingly, the efficiency will reduce accordingly.

传动效率
Efficiency

指在额定负载情况下，减速机的传动效率。减速比越大，级数越多，效率越低。
It refers to the gearing efficiency of the gearboxes in the case of the largest load.

平均寿命
Average lifetime

指减速机在额定负载下，额定输入转速是减速机的连续工作时间。
The rated input speed is the continuous working time of the reducer under the rated load.

定位精度
Prise Positioning

在高速机械往复运动中做到精确定位的关键在于尽量减少通过运动产生的角偏差。定位精度取决于两个值，一个与加载有关的偏转角，涉及回程间隙和扭转刚度；另一个是与运动控制有关的偏转角，涉及到同步偏差问题。
In high-speed reciprocating mechanical movement achieve precise Positioning, is the key to minimizing the movement through the angular deviation, positioning accuracy depends on the two values, with a load of the ration angle, involving partial synchronization the problem worse.

回程间隙背隙
Backlash

减速机输出轴与输入轴的最大角偏差，测量时先将齿轮输入轴固定住，然后在输出轴用力矩仪加载一定力矩（ $2\%T_N$ ），以克服减速机内的摩擦力。
The maximum angular deviation between the output shaft and the input shaft of the reducer is measured by fixing the gear input shaft, and then loading a certain moment ($2\%T_N$) on the output shaft with a torquer to overcome the friction in the reducer.

迟滞曲线
hysteresis cycle

迟滞曲线是为了得出减速的扭转刚度，通过检测到迟滞曲线。检测时，先将减速机输入端固定住，然后在输出端的两个旋转方向分别持续地加载到 T_{20} 最大输出力矩。继而逐步卸载，用仪器记录下力矩的仿差角，得到的曲线是一条闭合曲线，从中可以计算出减速机回程间隙(j)和扭转刚度(C_{21})。
The hysteresis curve is used to obtain the torsional stiffness of deceleration, and the hysteresis curve is detected. During the detection, the input end of the reducer is fixed, and then the maximum output torque of T_{20} is continuously loaded in the two rotating directions of the output end. Then unloading step by step and recording the imitation angle of the moment with the instrument, the curve obtained is a closed curve from which the return clearance (j) and torsional stiffness (C_{21}) of the reducer can be calculated.

转动惯性
Inertia

本说明书中的该值均指输入端。表示一个物体尽力保持转动状态（或机静止或转动）特征的一个值。
This value in this specification refers to the input end. A value representing the characteristic of an object trying to maintain its rotational state (or the machine being stationary or rotating).

惯量比
The proportion of ratio

是指负载惯量与传动系统惯量（电机加上减速机）之间的比值。这个比值决定了系统的可控性。值越大，也就是个转动惯量差值越大，高动态的动作过程就越难精确控制，建议尽可能将值控制在 <5 。齿轮箱可以将负载惯量降低 $1/i^2$ 。
It refers to the ratio between load inertia and transmission inertia (motor plus reducer). This ratio determines the controllability of the system. The greater the value, that is, the greater the difference of inertia, the more difficult it is to accurately control the high dynamic motion process. It is suggested that the value be controlled at < 5 as far as possible. Gearbox can reduce load inertia by $1/i^2$.

噪音
Noise

单位是分贝(dB)。此数值是在输入转速为3000转/分时，不带负载，距离减速机一米距离是测量的。
The unit is decibel(dB). This value is measured at the input speed of 3000 rpm without load and one meter away from the reducer.

额定输出扭矩
Rated output torque
 T_N [Nm]

T_N [Nm]减速机长时间（连续工作制）可以加载的力矩（无磨损），条件应满足负载均匀，安全系数 $S=1$ ，AF140以下机型，理论寿命为20000小时；AF180以上机型理论寿命为10000小时； T_N 值遵守ISODP6336齿轮标准与ISO281轴承标准。
 T_N [Nm] reducer can be loaded for a long time (continuous working system) without wear and tear. The condition should satisfy the uniform load, safety factor $S=1$, AF140 model, theoretical life is 20 000 hours: AF180 model, theoretical life is 10 000 hours: T_N value conforms to ISODP6336 gear standard and ISO281 bearing standard.

Basic Concepts Related to Type Selection

选型相关的基本概念

<p>加速扭矩 Accelerating Torque T_{2B}[Nm]</p>	<p>指工作周期每小时少于1000次时允许短时间加载到输出端的最大力矩。工作周期每小时大于1000次时，须考虑冲击因素，加载扭矩是周期工作制选型时的一个最大值，实际使用中的加速力矩必须小T_{2B}，否则会缩短减速机的寿命。</p> <p>It refers to the maximum moment that can be loaded to the output in a short time when the working cycle is less than 1000 times per hour. When the working cycle is more than 1000 times per hour, the impact factor must be considered. Loading torque is the maximum value in the selection of periodic working system. The acceleration moment in actual use must be smaller than T_{2B}, otherwise the life of reducer will be shortened.</p>
<p>紧急制动扭矩 Emergency braking torque T_{2HOT}[Nm]</p>	<p>指减速机输出端所能加载的最大力矩，这个力矩可在减速机寿命期内加载1000次，绝对不能超过1000次。（备注：AF140以下机型为$T_{2HOT}=2*T_{2B}$，AF180以上机型为$T_{2HOT}=1.5*T_{2B}$）</p> <p>It refers to the maximum moment that can be loaded at the output end of the reducer. This moment can be loaded 1000 times in the lifetime of the reducer, absolutely not more than 1000 times.(Note: The models below AF140 are $T_{2HOT}=2*T_{2B}$, AF180 model above are $T_{2HOT}=1.5*T_{2B}$.)</p>
<p>空载扭矩 No-load Torque T_{012}[Nm]</p>	<p>指加载到减速机上的以克服减速机内摩擦力的力矩。</p> <p>Refers to the moment loaded on the reducer to overcome friction in the reducer.</p>
<p>最大输出扭矩 Maximum output torque T_{2max}</p>	<p>指减速机在静态条件或频繁启动条件下所能承受的输出扭矩，通常指峰值负载或启动负载。</p> <p>Refers to the gearbox output torque can be loaded under static conditions or frequent starts conditions, usually refers to the peak load or the start load.</p>
<p>实际所需扭矩 Actual required torque T_2[Nm]</p>	<p>所需扭矩取决于应用场合的实际工况，拟选减速机的额定扭矩T_{2N}必须大于这个扭矩。</p> <p>The required torque depends on the actual conditions of the applications, to be selected rated torque T_{2N} must be greater than the required torque.</p>
<p>计算扭矩 Computational Torque T_{c2}[Nm]</p>	<p>会在选择减速机时被用到，可以由实际所需扭矩T_2和系数f_s，按以下公式得出$T_{c2}=T_2*f_s \leq T_{2N}$</p> <p>$T_{c2}=T_2*f_s \leq T_{2N}$ can be obtained from the following formulas, which can be used to select the reducer. The actual required torque T_2 and coefficient f_s can be used to calculate the $T_{c2}=T_2*f_s \leq T_{2N}$.</p>
<p>轴向力 axial force F_a[N]</p>	<p>是指平行于轴心的一个力，它的作用点与输出轴端有一定的轴向偏差(Y_2)时，会形成一个额外的弯绕力矩。轴向力超过样本所示的额定值时，须用联轴节来抵消这种弯绕力。</p> <p>It refers to a force parallel to the axis. When its action point has a certain axial deviation (Y_2) from the output shaft end, it will form an additional bending moment. When the axial force exceeds the rated value shown in the sample, the bending force shall be offset by the coupling.</p>

<p>径向力 radial force F_r[N]</p>	<p>指垂直作用于轴向力的一个力，它平行于输出轴，它的作用点与轴端有一定的轴向距离(X_2)。这个点成一个杠杆点，横向力形成一个弯绕力矩。</p> <p>A force acting perpendicularly on the axial force, parallel to the output axis, has an axial distance (X_2) between the action point and the end of the axis. This point is a lever point, and the lateral force forms a bending moment.</p>
<p>轴伸径向载荷、轴向载荷 Axis Extension Radial Load and Axis Load</p>	<p>选择减速机的附加依据是输出轴伸出端上的径向载荷和轴向载荷。轴的强度和轴承的承载能力决定了轴伸的的径向载荷。产品样本中给出的最大允许值是指在最不利的方向作用轴伸出端中点（即1/2L处）的力。当作用力不在中点时，越接近轴肩，允许的径向载荷就越大；相反，作用点离轴肩越远，允许的径向载荷就越小。</p> <p>The additional basis for selecting the reducer is the radial and axial loads on the extension end of the output shaft. The strength of the shaft and the bearing capacity determine the allowable radial load of the axle extension. The maximum allowable value given in the product sample refers to the force at the midpoint (i.e. 1/2L) where the axis extends in the most disadvantageous direction. When the force is not at the midpoint, the closer to the shoulder, the greater the allowable radial load; on the contrary, the farther the action point is from the shoulder, the smaller the allowable radial load.</p>
<p>安全系数 S safety factor</p>	<p>安全系数等于减速机的额定输入功率的比值。</p> <p>The safety factor is equal to the ratio of the rated input power of the reducer.</p>
<p>使用系数 f_s Coefficient of use</p>	<p>使用系数表现减速机的应用特征，它考虑发哦减速机的负载类型和每日工作时间。</p> <p>The coefficient of use represents the application characteristics of the reducer. It considers the load type and working time of the reducer.</p>
<p>扭转刚度 C_{21} Torsional stiffness [Nm/Arcmin]</p>	<p>由加载力矩和所产生的扭转角之间的比率来定义。$C_{21}=\Delta T/\Delta \phi$ 它说明需要用多大的力矩才能把输出轴转动一弧分。扭转刚度是从迟滞曲线得出的。在曲线图上只需要关注T_{2B}的50%到100%这个范围，在这个范围内，曲线可看成是一条直线。</p> <p>It is defined by the ratio between the loading moment and the resulting torsion angle. $C_{21}=\Delta T/\Delta \phi$ indicates how much torque is required to rotate the output shaft in an arc. Torsional stiffness is derived from hysteresis curve. In the graph, only 50% to 100% of T_{2B} is needed to be concerned. In this range, the curve can be regarded as a straight line.</p>
<p>安装力矩 Installation Torque [Nm]</p>	<p>减速机的组装以及电机与减速机连接安装（输入轴采用弹性联轴器要求），都是有力矩要求。建议使用力矩扳手来完成安装步骤。</p> <p>The assembly of reducer and the connection between motor and reducer (the requirement of elastic coupling for input shaft) are all strong moment requirements. It is recommended to use the moment wrench to complete the installation steps.</p>

减速机专用名词解释

Explanation of special terms for reducer



[如]

定位精确度：在高速机械往复运动中做到精确定位的关键在于尽量减小通过运动产生的角偏差，定位精确度取决于两个值，一个是与加载有关的偏转角，涉及到回程间隙与扭转刚度，另一个是与运动控制有关偏转角，涉及到同步偏差问题。

转动惯量J[Kgcm²]：表示一个物体尽力保持自己转动状态(或静止或转动)特性的一个值。样本中的值均指输入端。

弧分 [Arcmin]：一度分为60弧分(=60 Arcmin=60')。如回程间隙标为1 Arcmin时,意思是说齿轮箱转一圈,输出端的角偏差为1/60°。在实际应用中,这个角偏差与轴直径有关 $b=2 \cdot \pi \cdot r \cdot a^\circ / 360^\circ$ 。就是说,输出端半径为500mm时,齿轮箱精度为 $jt=3'$ 时,齿轮箱转一圈的偏差为 $b=0.44\text{mm}$ 。

回程间隙jt [Arcmin]：指减速机输出轴与输入端的最大偏差角。测量时先将齿轮输入端固定住,然后在输出端用力矩仪加载一定力矩(2%T2B),以克服减速机内的摩擦力。

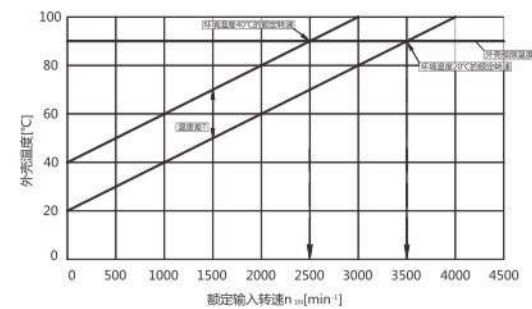

[如]

速比i：表示减速机改变某一运动的三个主要参数值的值，即通过减速机的速比来改变转速、扭矩和惯性力矩。

噪音[dB]：成套设备选用低噪音减速机，有助于环境保护和健康保护。速比与转速直接影响到噪音水平，一般是转速越高，噪音越大；速比越大噪音越小。样本中的值是在输入转速为3000rpm/min时，不带负载，离减速机一米距离时测量的。

平均寿命[h]：指减速机在额定负载下，额定输入转速时的连续工作时间。

转速(n)：减速机选型时必须考虑的两个转速是最大输入转速和额定输入转速。为间歇工作制选用减速机时，要考虑不能超过最大输入转速 $n1_{max}$ 。为连续工作制选用减速机时，要考虑不能超出最大额定转速 $n1_N$ 。额定转速受到减速机外壳温度的限制，这个温度不能超过90℃。从下图中可以看出，环境温度越高时，减速机的温度也提前达到额定温度。换句话说，在环境温度高时必须降低转速。

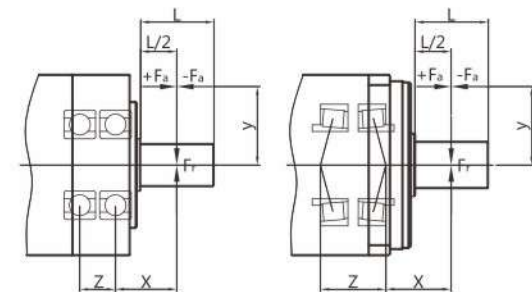

[如]

额定输入转速n1[rpm]：减速机的驱动速度，如减速机与电机直接相连，则转速值与电机转速相同。本书中的额定输入转速是在环境温度为20℃的条件下测得的，环境温度较高时请降低转速 $n1$ 。

传动效率 η ：由于摩擦引起的损失总是使效率小于1，也就是少于100%。样本上的效率是齿轮箱在满负荷运动情况下，减速机的传输效率。

额定输出扭矩 [Nm]：指减速机长时间(连续工作制)可以加载的力矩(无磨损)，条件应满足负载均匀，安全系数 $S=1$ ，理论寿命为20000小时；T2N值遵守ISO DP 6336齿轮标准与ISO 281轴承标准。

空载扭矩 [Nm]：指加载到减速机上以克服齿轮箱内的摩擦力的力矩。样本所标值是在转速为3000rpm，环境温度在20℃时的测得的。

轴向力FaMax[N]：是指平行于轴心的一个力。它平行于输出轴。它的作用点与输出轴端有一定的轴向偏差(y)时，会形成一个额外的弯矩。轴向力超过样本所示的额定值时，须用联轴节来抵消这种弯矩。

径向力FrMax[N]：指垂直作用于轴向力的一个力。它的作用点与轴端有一定的轴向距离(x)，这个点成一个杠杆点。横向力形成一个弯矩。

工作温度 / Operating temp	℃	(-40) - 25bis/to + 90(+120)
保护等级 / Degree of protection		IP65
润滑 / Lubrication		长效润滑 / Life time lubrication
安装方式 / Mounting position		任意 / Any
法兰标准 / Motor flange precision		Din 42955-N

减速机安装指南

Speed reducer installation guide

第一步

确认电机和减速机是否完好(若有电机轴键,需移走)

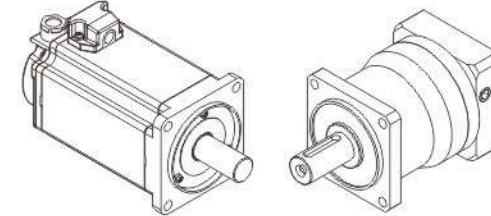

安装前确认电机和减速机是否完好无损,并且严格检查电机与减速机相连接的各部位尺寸是否匹配,主要指电机的凸台尺寸与减速机凹槽等尺寸及配合公差。

第二步

将电机轴和减速机的连接部分清洁干净

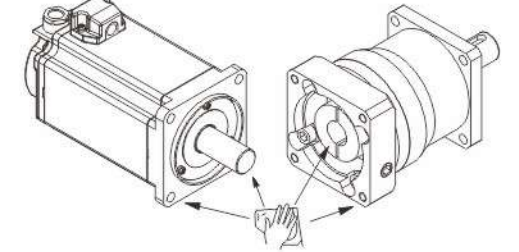

将电机输出轴、定位凸台及减速机连接部位的防锈油用汽油或锌钠水擦拭干净,其目的是保证连接的紧密性及运转的灵活性,并且防止不必要的磨损。

第三步

旋掉减速机法兰外侧的螺钉,插入内六角扳手

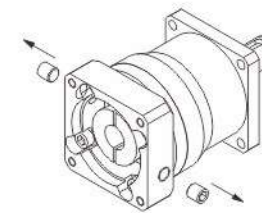

取下减速机法兰外侧工艺孔上的防尘盖,调整减速机输入轴弹性夹装置使其紧固螺栓与工艺孔对齐,插入内六角扳手。此步骤适合筒夹式锁紧机构联接。

第四步

将电机和减速机自然连接,严禁敲打

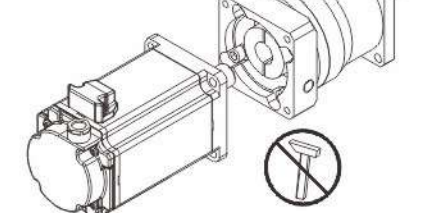

连接时必须保证减速机输出轴与电机输入轴同轴度一致,且二者外侧法兰平行,如果轴度不一致,会导致电机轴折断或减速机齿轮磨损。另外,在安装时,严禁用铁锤等击打,防止轴向力或径向力过大损坏轴承或齿轮。

第五步

试连接好,并准备安装螺钉

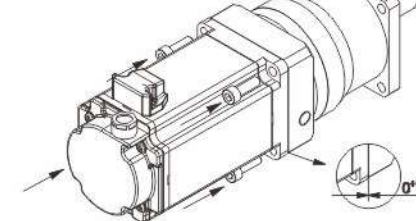

在电机与减速机连接前,请先将减速机锁紧螺钉对准工艺孔,便于扳手介入。

第六步

锁紧固定螺钉

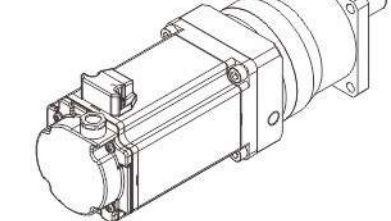

为保证受力均匀,请先将任意对角的安装螺钉旋上,但不要旋紧,再旋上另外两个对角的安装螺钉,最后逐个旋紧四个安装螺钉。

第七步

锁紧抱紧螺钉,扭力的上限值见下表

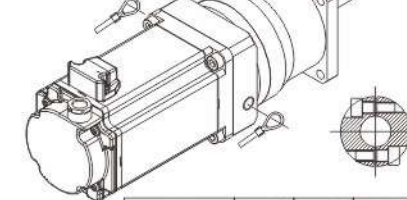

型号	60系列	85系列	115系列	140系列
螺钉规格	M5	M6	M8	M10
锁紧扭矩(Nm)	9.5	16.5	40	80

减速机抱紧螺钉有两颗,请逐步加力,均匀锁紧。

第八步

安装工艺螺钉

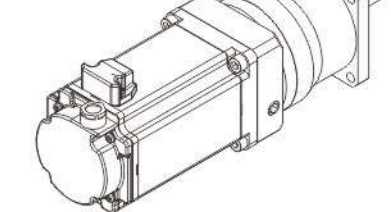

工艺螺钉的安装可以更好的达到防护等级。