

GROWING TOGETHER

MiIMY
LINEAR MOTION PRODUCTS



SUPER SONIC

SUPER SONIC HOUSE, Plot No. C-10/5-6, Soma Kanji Estate-2, (SK-2),
Near Sosyo Circle, Opp. Sanidev Temple, Udhna Magdalla Road,
Surat (Gujarat) India - 395007 | www.supersonicgroup.in
For Enquiry Contact : +91 261 2634263, 95124 51510
e-mail : supersonichouse06@gmail.com

Product Selection Guide

To reduce complexity and cost of a design, it is important to accurately size a motor / lead screw combination. Belows are a few simple steps in selecting the necessary compotents for a given application.

STEP 1 – CHOOSING A MOTOR SIZE (FORCE REQUIREMENTS)

Here is a general overview of the output thrust vs. motor size:

	Motor Sizes (mm)	Max Thrust (N)	Recommended Load Limit (N)
Linear Actuators	14	15	11
	20	70	45
	28	150	140
	35	300	200
	42	600	230
	57	1300	910
	60	1560	910
	86	2400	2270

As the size of the motor increases, the output thrust of the motor correspondingly increases.

STEP 2 – CHOOSING A SCREW LEAD (FORCE AND SPEED REQUIREMENTS)

After estimating the required thrust and choosing a motor size that may fit your application, the speed and acceleration of the load must be considered and evaluated to choose an appropriate screw lead.

Due to the nature of lead screws, the output speed and output thrust achievable by a motor/lead screw combination are two proportional. (i.e., increasing the required thrust will lower the achievable speed for a motor/lead screw combination). Therefore, the maximum output force of a system is lowered for applications that requires higher speed.

For complete motor/lead screw selection data, please refer to the speed vs thrust curves for each motor size.

Although these two steps provide a solid foundation in motor/lead screw selection, other variables must also be considered:

- Duty Cycle
- Desired Life of a System
- Environmental Considerations
- Positional Repeatability
- Acceptable Backlash
- Acceleration/Deceleration
- Driver Specifications
- Vertical or Horizontal

Because of the numerous variables involved in motor selection, it is highly recommended for users to proceed with physical testing to accurately determine the motor/lead screw combination required for a given application.

NOTE : Although this section aims to provide a rough guide line to select a motor/lead screw combination that best fits an application, we recommend to contact our application engineering staff or sales representatives for further assistance with the motor selection process.

Technology Overview

One of the most common methods of moving a load from point A to point B is through linear translation of a motor by a mechanical lead screw and nut. This section is here to assist and refresh your understanding of the basic principles of lead screw technology prior to selecting the system that is best for your application.

Some basic design consideration are as follows:

1. What is the load of your system?
2. What is the required linear speed?
3. What is the distance to be travelled?
4. What accuracy does your application require?
5. What is the required time to move from point A to point B?
6. What repeatability does your application require?
7. Horizontal vs vertical orientation?

TERMINOLOGY

LINEAR ACTUATOR TYPES

- A. Captive
- B. Non-captive
- C. External Linear
- D. Linear mouldue



LEAD

Lead is the axial distance the nut advances on one revolution of the screw. Throughout this catalog, lead will be the term used for revolution a screw as it is the linear distance traveled for one revolution of the screw. The larger the lead, the more linear distance traveled per one revolution of the screw. $Lead = Pitch \times screw\ start$.

PITCH

Pitch is the axial distance between threads. Pitch is equal to lead in a single start screw. There may be more than one thread "strand" on a single screw. These are called starts. Multiple start lead screws are usually more stable and efficient at power transmission.

ACCURACY OF SCREW

Specified as a measurement over a given length of the screw. For example: 0.004 inch per foot. Lead accuracy is the difference between the actual distance traveled versus the theoretical distance traveled based on the lead. For example: A screw with a 0.5 inch lead and 0.004 inch per foot lead accuracy rotated 24 times theoretically moves the nut 12 inches. However, with a lead accuracy of 0.004 inch per foot, actual travel could be from 11.996 to 12.004 inches.

POSITION TOLERANCE

The approach value between actual distance traveled vs theoretical distance traveled.

REPEATABILITY

Most motion applications put the most significance on the repeatability (vs accuracy of screw) of a system to reach the same commanded position over and over again.

HORIZONTAL OR VERTICAL APPLICATION

Vertical orientation applications add the potential problem of backdriving when power to the motor is off and without an installed brake. Vertical application also have an additional gravity factor that must be part of the load/force calculation.

TOTAL INDICATED RUNOUT

The amount of "wobble" around the centerline of the screw.

- **VIBRATION AND NOISE**

The hybrid stepper motor's resonance will be occurred when pulse is up to 200PPS. Try starting your acceleration ramp at above these levels. Micro-stepping will also help through these ranges.

- **STATIC LOAD**

The maximum thrust load, including shock load, that should be applied to a non-moving screw.

- **DRIVER**

Stepper motors require some external electrical components in order to run. These components typically include a power supply, logic sequencer, switching components and a clock pulse source to determine the step rate. Many commercially available drives have integrated these components into a complete package. Some basic drive units have only the final power stage without the controller electronics to generate the proper step sequencing.

- **DYNAMIC LOAD**

The maximum recommended thrust load which should be applied to the screw while in motion.

- **HOLDING TORQUE**

When motor is static and rated current is applied to two phase, the stator's holding ability to the rotor.

- **ROTOR INERTIA**

Moment matters when accelerate or decelerate.

- **TRAVEL PER STEP**

The linear travel movement of one full step of the motor.

- **TEMPERATURE RISING**

Motor body's temperature rising after certain periods running and heat exchange with the ambient.

- **RESPONSE PER STEP**

Times takes to complete one step.

- **STEP**

Characteristics of stepper motor that the rotor moves step by step as the stator commutates phase by phase.

- **STEP ANGLE**

Angular movement of every step.

- **PULL OUT TORQUE**

Under certain drive condition (frequency and current), the max load that the motor can drag until missing step.

- **PULL IN TORQUE**

When couples and accelerates, the max load torque (including frictions) that the motor can bear and start.

- **EFFICIENCY**

The ability of a mechanical system to translate an input to an equal output.

- **RESOLUTION**

Incremental linear distance the actuator's (motor) output shaft will move per input pulse.

- **TENSION OR COMPRESSION LOADING**

A load that tends to stretch the screw is called a tension load.

A load that tends to "squeeze" or compress the screw is called a compression load.

Depending on the size of the load, designing the screw in tension utilizes the axial strength of the screw versus column loading.

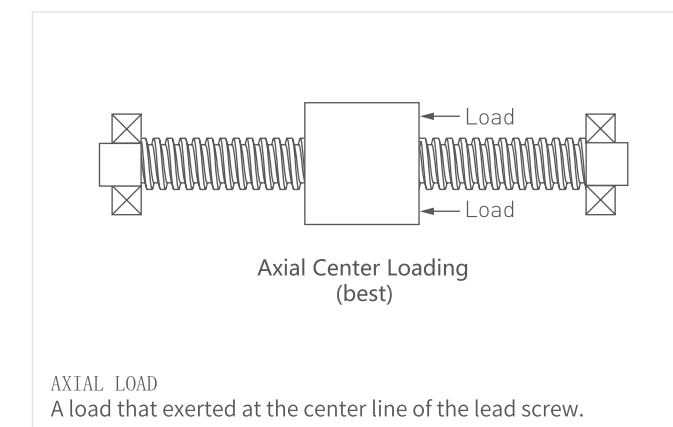
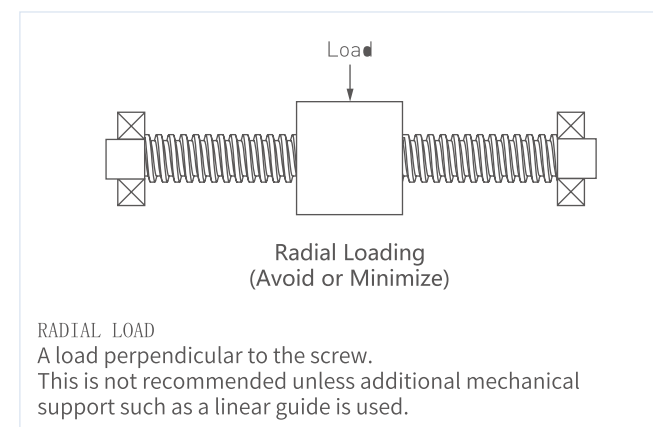
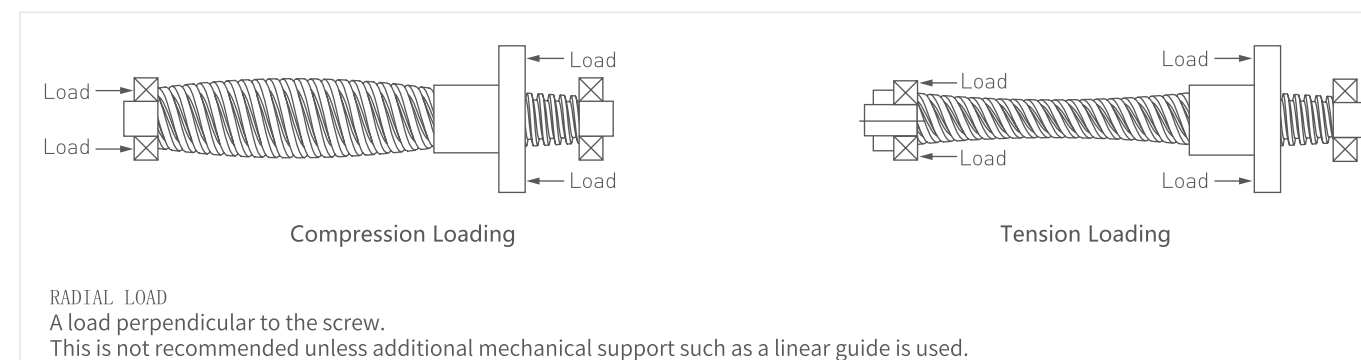

- **STATIC LOAD**

The maximum thrust load, including shock load, that should be applied to a non-moving screw.

- **DYNAMIC LOAD**

The maximum recommended thrust load which should be applied to the screw while in motion.

- **BACKDRIVING**

Backdriving is the result of the load pushing axially on the screw or nut to create rotary motion. Generally, a nut with an efficiency greater than 50% will have a tendency to backdrive. Selecting a lead screw with an efficiency below 35% may prevent backdriving. The smaller the lead, the less chance for backdriving or free wheeling. Vertical application is more prone to backdriving due to gravity.

- **TORQUE**

The required motor torque to drive just the lead screw assembly is the total of:

1. Inertia Torque
2. Drag Torque (friction of the nut and screw in motion)
3. Torque to move load

- **LUBRICATION**

The nut material contains a self-lubricating material that eliminates the need for adding a lubricant to the system. The Teflon coated screw option also lowers friction and extends life of the system

- **END MACHINING OF THE SCREW**

Standard metric or English option are available. Custom end machining specifications are also available on request. Please contact your local DINGS' representative.

● **FIXITY**

The performance (speed and efficiency) of the screw system is affected by how the screw ends are attached and supported.

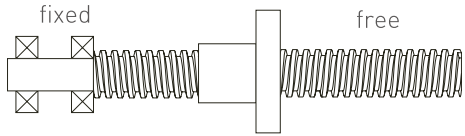
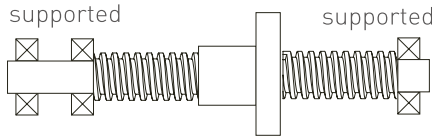
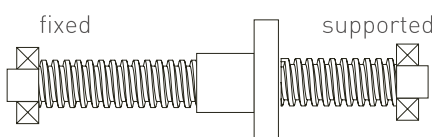
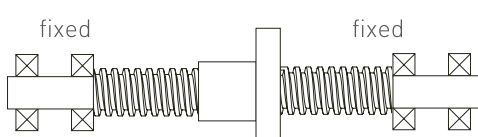
Type of End Fixity	Relative Rigidity	Critical Speed Factor	Critical Load Factor
	Less Rigid	0.32	0.25
	Rigid	1.0	1.0
	More Rigid	1.55	2.0
	More Rigid	2.24	4.0

● **COLUMN STRENGTH**

When a screw is loaded in compression, its limit of elastic stability can be exceeded and the screw will fail due to bending or buckling.

● **CRITICAL SPEED**

Critical speed is the rotational speed of the screw at which the first harmonic of resonance is reached due to deflection of the screw. A system will vibrate and become unstable at these speeds.

Several variables affect how quickly the system will reach critical speed:

1. The lead of the screw
2. The rotational speed
3. End fixity
4. Thrust load
5. Diameter of the screw
6. Tension or compression loading

An example in the figure, it shows the screw rod with a diameter of 19.05mm (0.75inch) and a length of 1778mm (70inch) has a safety factor of $K = 1.25$,

And under the fixed mode of $FS = 0.32$, the critical speed is 187rpm.

● **CRITICAL ROTATION SPEED (RPM) VS. UNSUPPORTED SCREW LENGTH FOR VARIOUS SCREW DIAMETERS (INCH)**

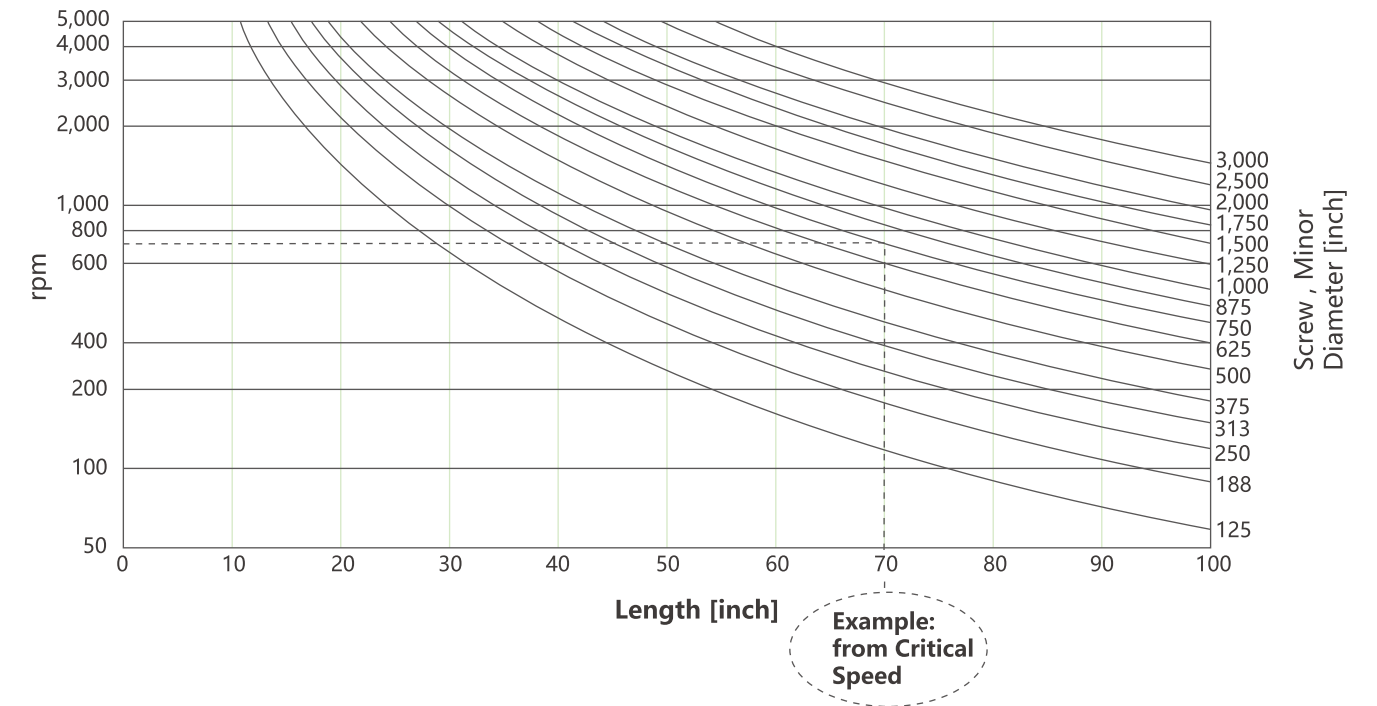

● **BACKLASH**

Backlash is the relative axial movement between a screw and nut at standstill. It is normal for backlash to increase with wear over time. Backlash compensation or correction can be accomplished through the application of an anti-backlash nut. Backlash is usually only a concern with bi-directional positioning.

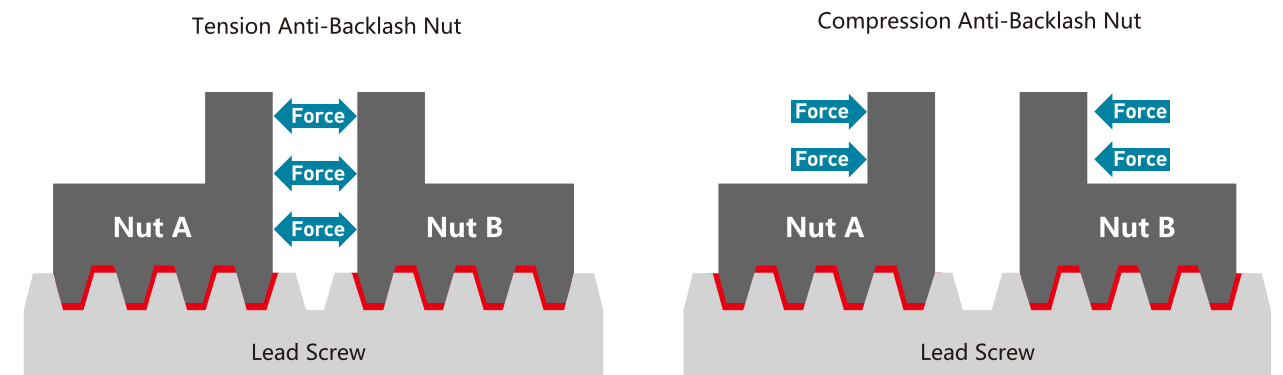
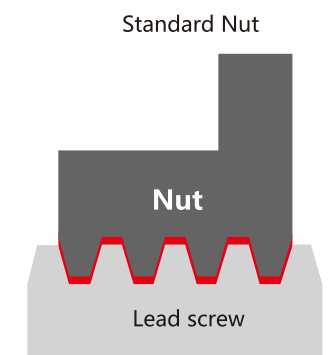

BACKLASH IN RED

• Stepper motor : Wiring

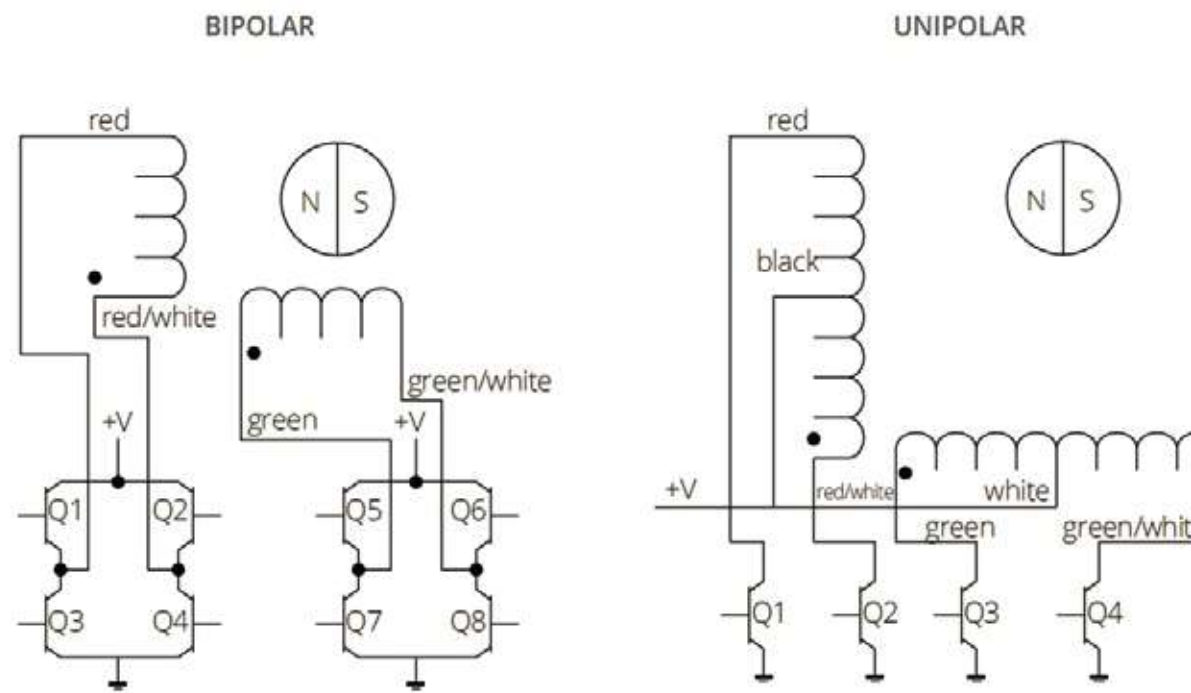

• Stepper motor : Stepping sequence

深鷓駒°	纒J nP	nN/nQ	nSJnT	nRJnU
苟難鱗裏	nN	nO	nP	nQ
胥鎔				
N	l k	l cc	l k	l cc
O	l cc	l k	l k	l cc
P	l cc	l k	l cc	l k
Q	l k	l cc	l cc	l k
R	l k	l cc	l k	l cc

Note: Inserting an off state in phase sequence conversion can achieve half step stepping

MIMY Motion Part Number Codes

PS	42	C	1	A		070	0254	A01
Prefix (as required)	Size	Form	Stack Length	Lead Code (mm)		Current (A)	Lead Screw Length or Stroke (mm)	Series Number
BS=Ball Screw or Ball Spline assembly	Motor Size	C=Captive	1=Single Stack	AT=0.3	AD=4	For Example: 070=0.7A 091=0.91A 300=3A	For Example: 0254=25.4mm 0500=50mm 1000=100mm	
	14=14mm(Size6)							
	20=20mm(Size8)	E=External	2=Double Stack	U=0.3048	T=4.2334			
LS=Lead Screw Assembly or Lead Screw Only	28=28mm(Size11)	N=Non-Captive	3=Single Stack Extra	AU=0.4	Q=4.8768			
LN=Nut only	42=42mm(Size17)	DM=Dual-Motion	4=Double Stack Extra	AA=0.5	AR=5			
LM=Linear Module	57=57mm(Size23)	HS=Stepper motor	5=Others	N=0.6096	M=5.08			
PS=Proximity Sensor	86=86mm(Size34)	DC=Direct Current motor		D=0.635	AS=6			
SS=Spline shaft assembly or Spline shaft only	Lead Screw or Spline shaft Diameter	BC=Brushless Motor		P=0.79375	C=6.35			
SN=Spline Nut	020=2mm	S = Servo Motor		AB=1	AE=8			
SP=Special Product	030=3mm			K=1.2192	G=8.4582			
	035=3.5mm			AW=1.25	H=9.525			
	040=4mm				R=9.7536			
	048=4.76mm			F=1.27	AF=10			
	050=5mm			AN=1.5	W=10.16			
	055=5.54mm			A=1.5875	AG=12			
	060=6mm			AC=2	Y=12.7			
	064=6.35mm			S=2.1167	AH=15			
	080=8mm			J=2.4384	AJ=16			
	095=9.53mm			AP=2.5	AK=18			
	100=10mm			L=2.54	AL=20			
	120=12mm			AQ=3	AM=24			
	125=12.5mm			B=3.175	Z=25.4			
	127=12.7mm							
	159=15.88mm							
	160=16mm							

For Example: PS42C1A070-0254-A01

42mm linear actuator, captive type, single stack, Lead 1.5875mm, current 0.7A, stroke 25.4mm,with proximity sensor.

Linear Actuator Series

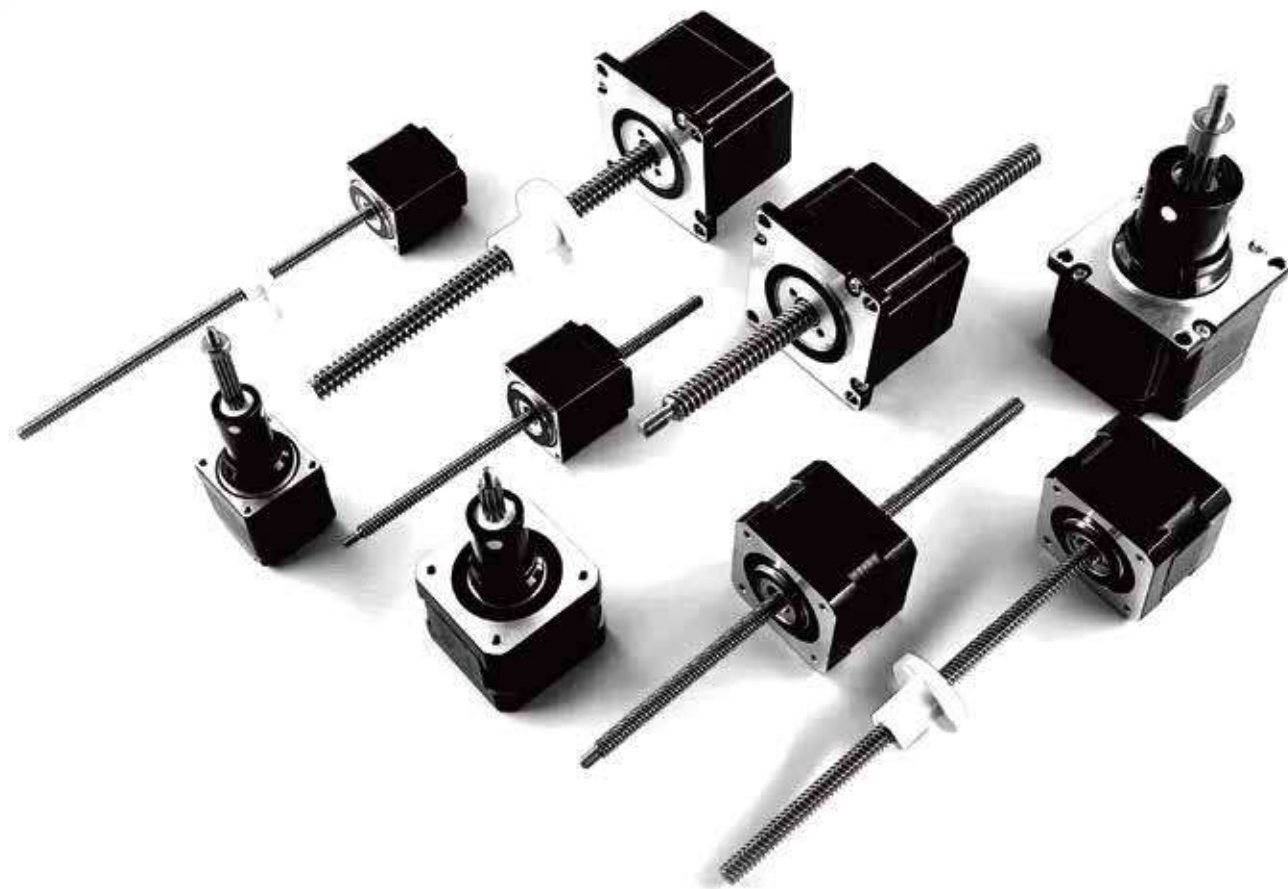

14mm(Size6) Linear Actuator

The 14mm(size 6) series is the smallest lead screw linear actuator, which providing an effective scheme for engineers to realize precision transmission in a limited space. The size 6 actuator provides thrust of up to 15N.



Electric Parameter

Size 6: 14mmHybrid Linear Motor (1.8°Step Angle)		
Part No.	External	14E1*
Wiring		Bipolar
Wiring Voltage		6.6VDC
Current/Phase		0.3A
Resistance/Phase		22 Ω ±10%
Inductance/Phase		4.2 mH
Power Consumption/Total		1.94W
Rotor Inertia		0.5gcm ²
Temperature Rise		135°F (75°C)
Insulation Class		Class B (Class F optional)
Weight		30g
Insulation Resistance		50MΩ

Linear Travel/Strp (mm)	Lead (mm)	Lead Code
0.0015	0.3	AT

Outline

lead screw length and end machining can be customised

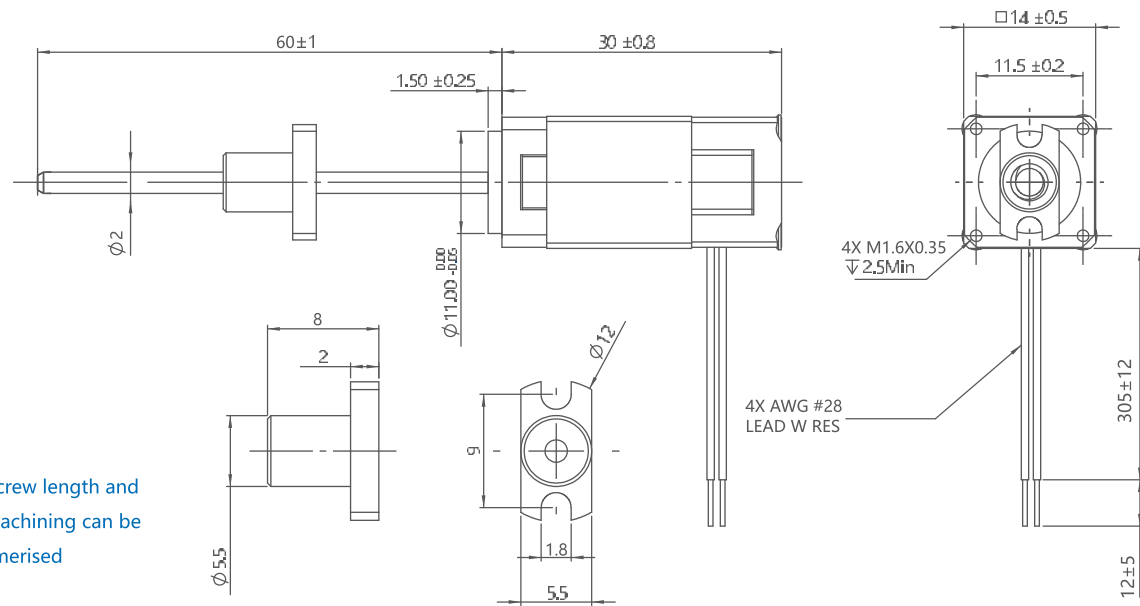

20mm(Size8) Linear Actuator , Single Stack

The 20mm(size8) series Linear Actuator are available in three designs, captive, non-captive and external, with leads from 0.6096mm to 8mm. Maximum thrust force is up to 7kg.



Force vs Pulse Curve

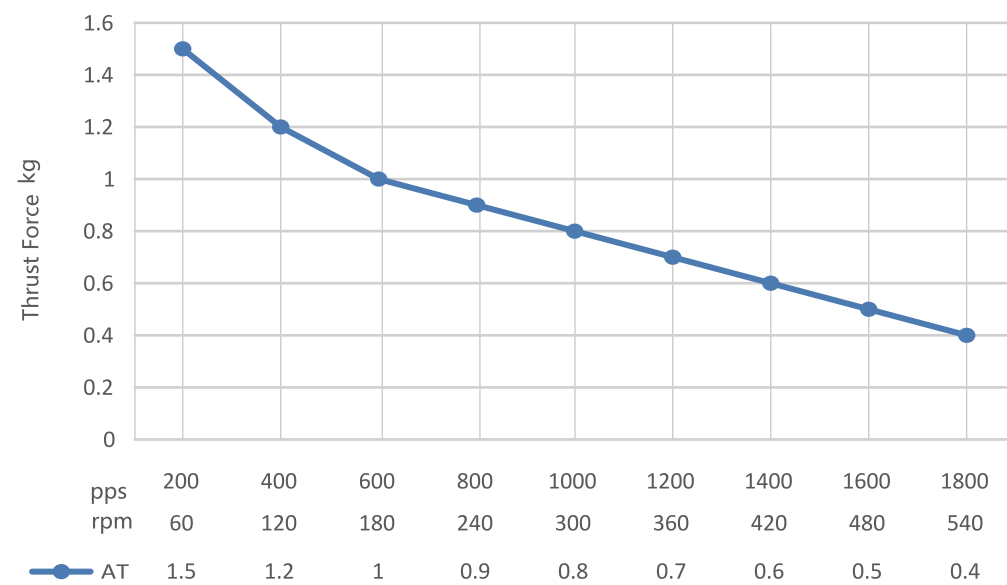

Electric Parameter

Size 8: 20mmHybrid Linear Motor (1.8°Step Angle)			
Part No.	captive	20C1*	
	non-captive	20N1*	
	external	20E1*	
Wiring	Bipolar		
Wiring Voltage	2.5VDC	5VDC	7.5VDC
Current/Phase	0.5A	0.24A	0.16A
Resistance/Phase	5.1Ω	20.4Ω	45.9Ω
Inductance/Phase	1.6mH	5.0mH	11.7mH
Power Consumption/Total	2.45W		
Rotor Inertia	1.4gcm ²		
Temperature Rise	135°F (75°C)		
Insulation Class	Class B (Class F optional)		
Weight	43g		
Insulation Resistance	20MΩ		

Linear Travel/Strp (mm)	Lead (mm)	Lead Code
0.003048	0.6096	N
0.006096	1.2192	K
0.005	1	AB
0.01	2	AC
0.02	4	AD
0.004	8	AE

Outline

Captive

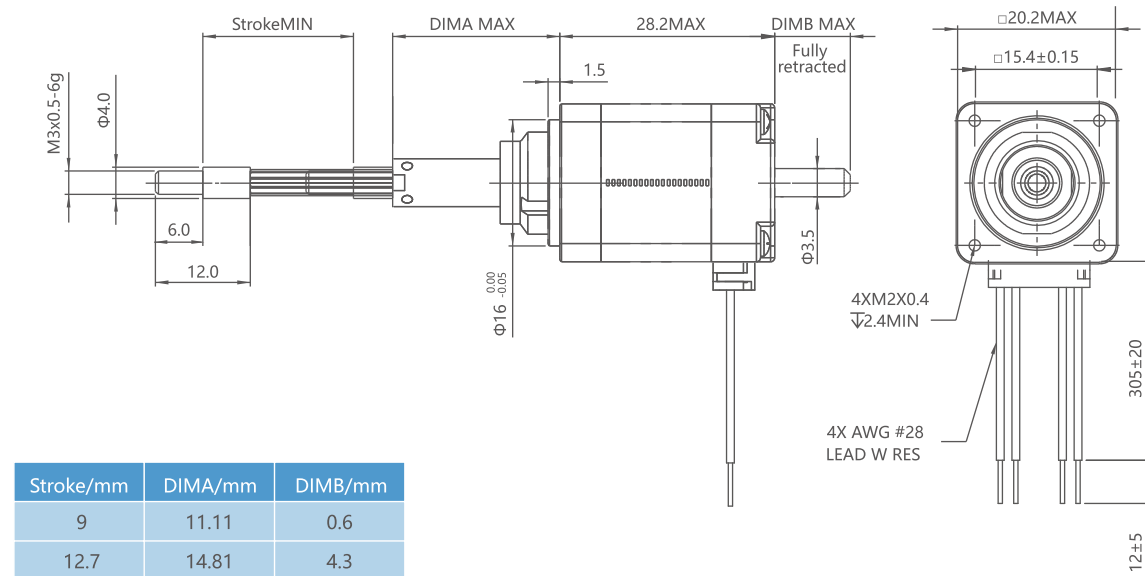

Stroke/mm	DIMA/mm	DIMB/mm
9	11.11	0.6
12.7	14.81	4.3
19.1	21.21	10.7
25.4	27.51	17
31.8	33.91	23.4
38.1	40.21	29.7
50.8	52.91	42.4

Non-captive

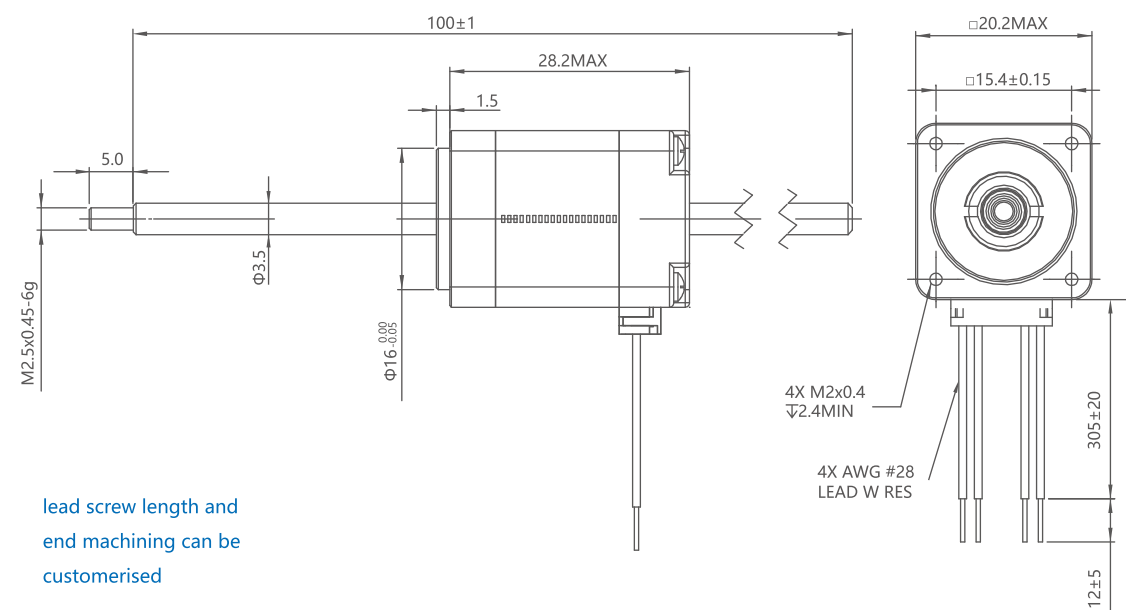

lead screw length and end machining can be customised

External

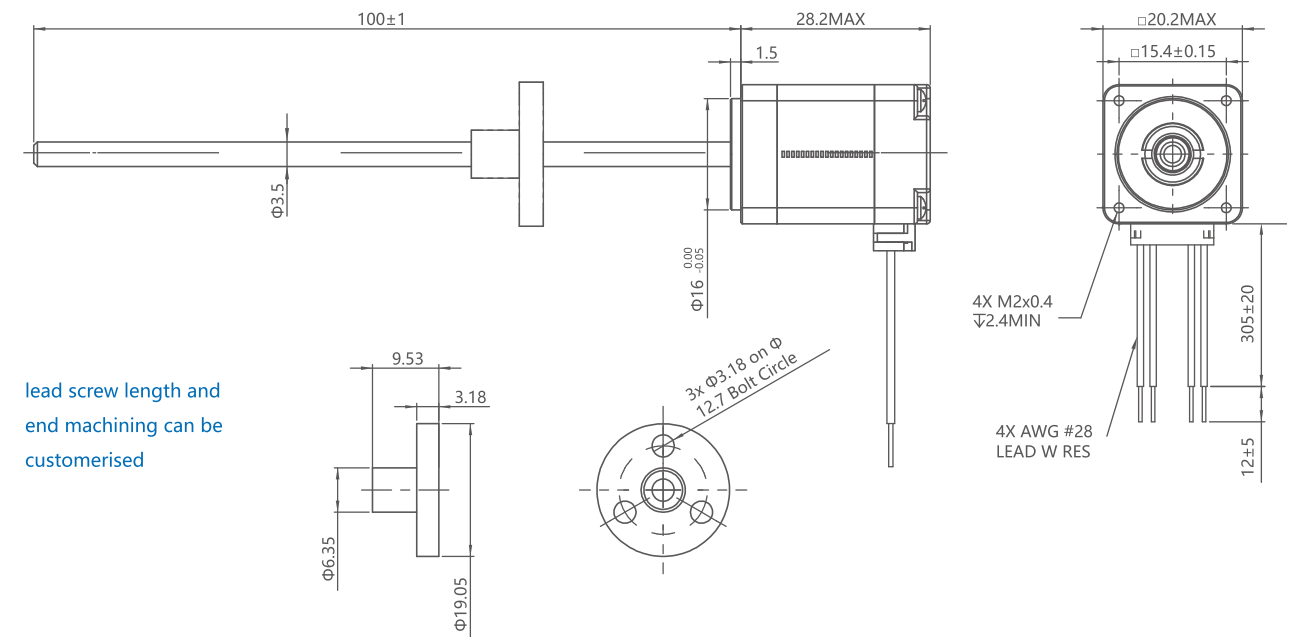

lead screw length and end machining can be customised

Force vs Pulse Curve

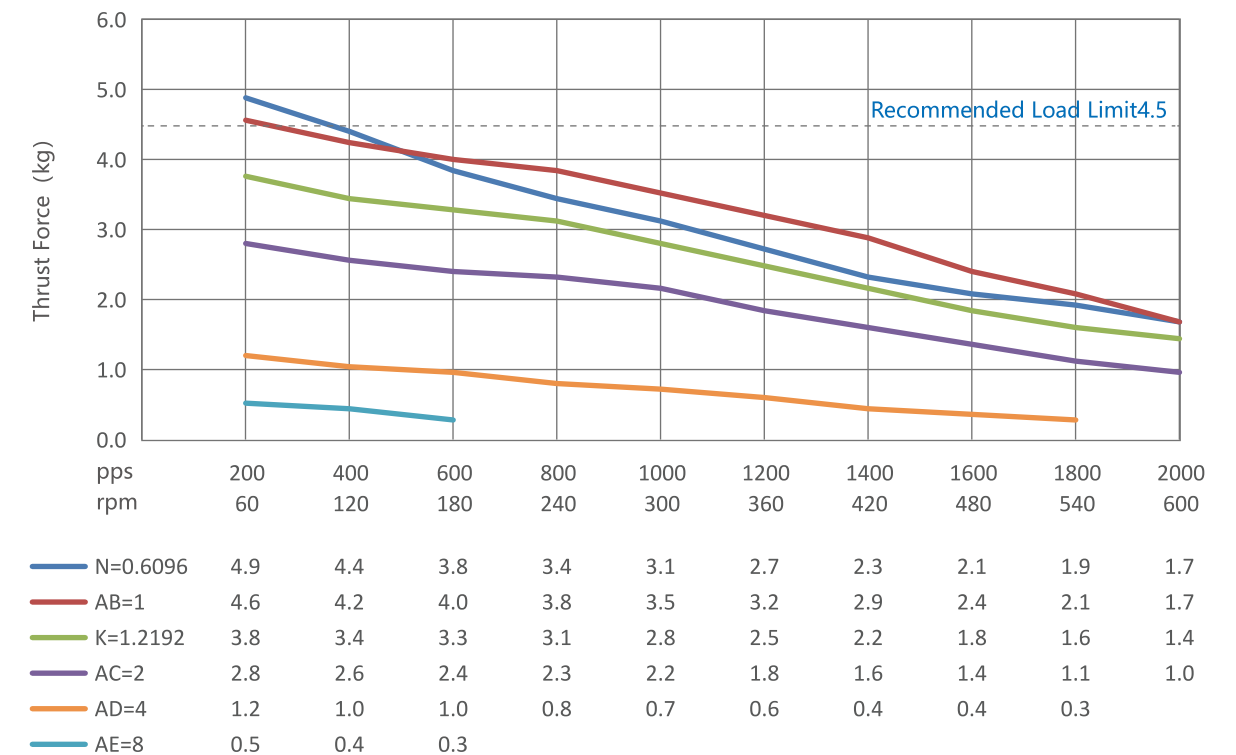

20mm(Size8) Linear Actuator , Double Stack

The 20mm(size 8) series Linear Actuator are available in three designs, captive, non-captive and external, with leads from 0.6096mm to 8mm. Maximum thrust force is up to 7kg.



Electric Parameter

Size 8: 20mmHybrid Linear Motor (1.8°Step Angle)			
Part No.	captive	20C2*	
	non-captive	20N2*	
	external	20E2*	
Wiring	Bipolar		
Wiring Voltage	2.5VDC	5VDC	7.5VDC
Current/Phase	1.32A	0.65A	0.43A
Resistance/Phase	1.9Ω	7.7Ω	17.3Ω
Inductance/Phase	0.75mH	3mH	16mH
Power Consumption/Total	6.5W		
Rotor Inertia	2.6gcm ²		
Temperature Rise	135°F (75°C)		
Insulation Class	Class B (Class F optional)		
Weight	68g		
Insulation Resistance	20MΩ		

Linear Travel/Strp (mm)	Lead (mm)	Lead Code
0.003048	0.6096	N
0.006096	1.2192	K
0.005	1	AB
0.01	2	AC
0.02	4	AD
0.004	8	AE

Outline

Captive

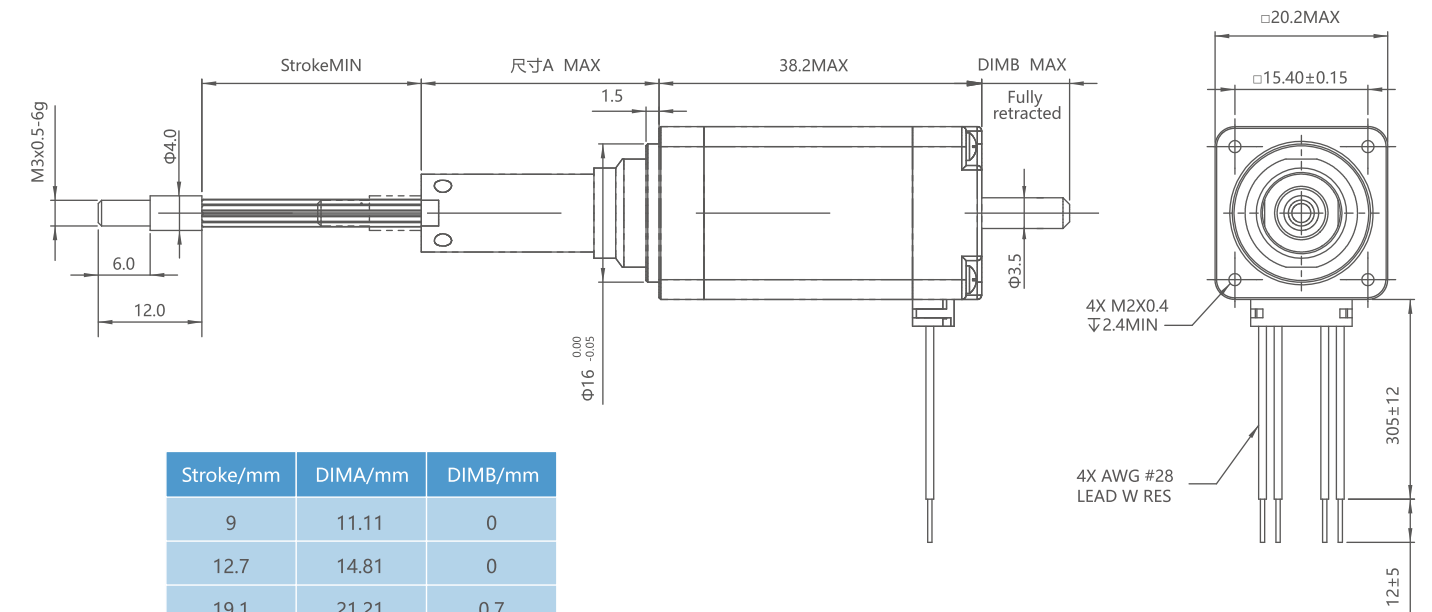

Stroke/mm	DIMA/mm	DIMB/mm
9	11.11	0
12.7	14.81	0
19.1	21.21	0.7
25.4	27.51	7
31.8	33.91	13.4
38.1	40.21	19.7
50.8	52.91	32.4

Non-captive

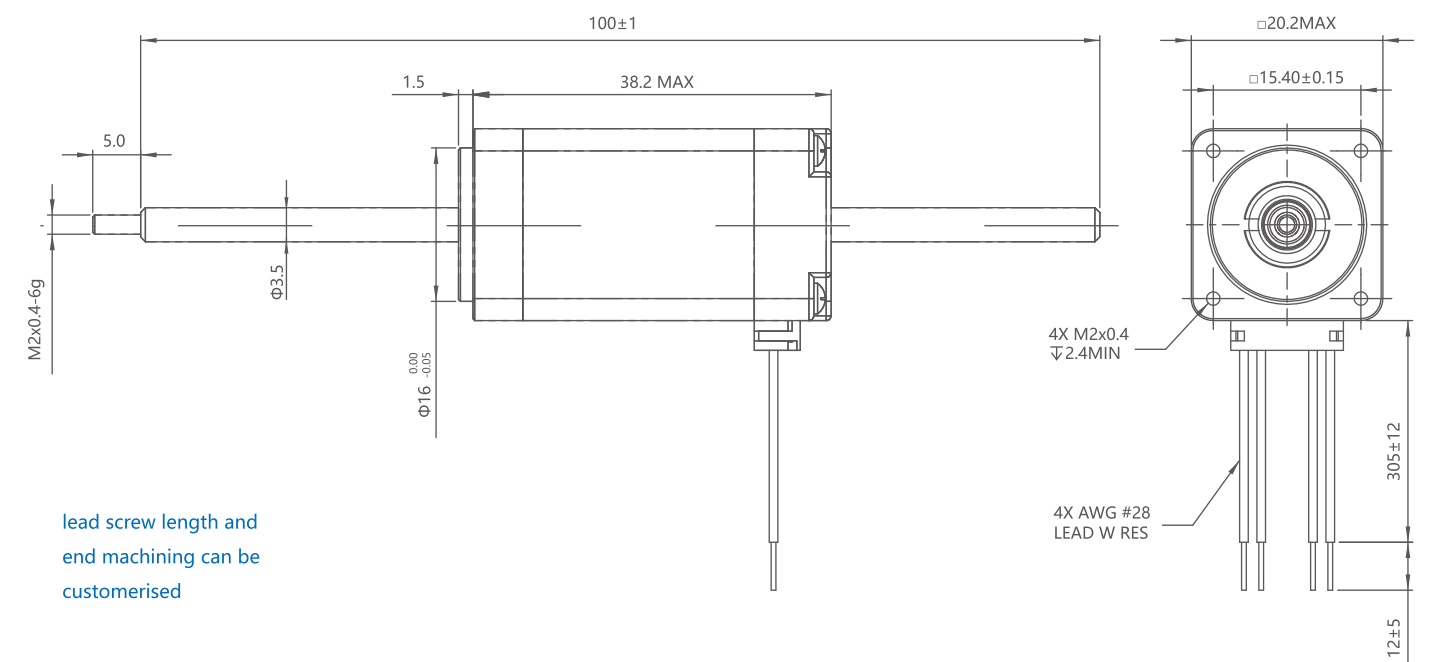

lead screw length and end machining can be customised

External

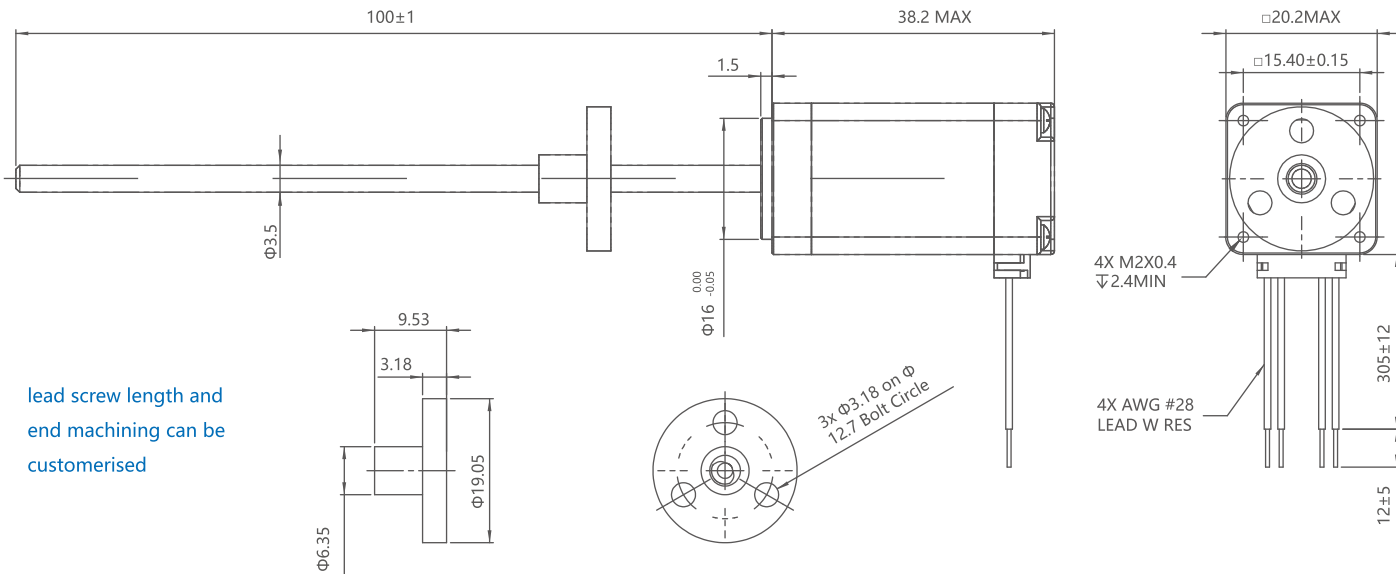

lead screw length and end machining can be customised

Force vs Pulse Curve

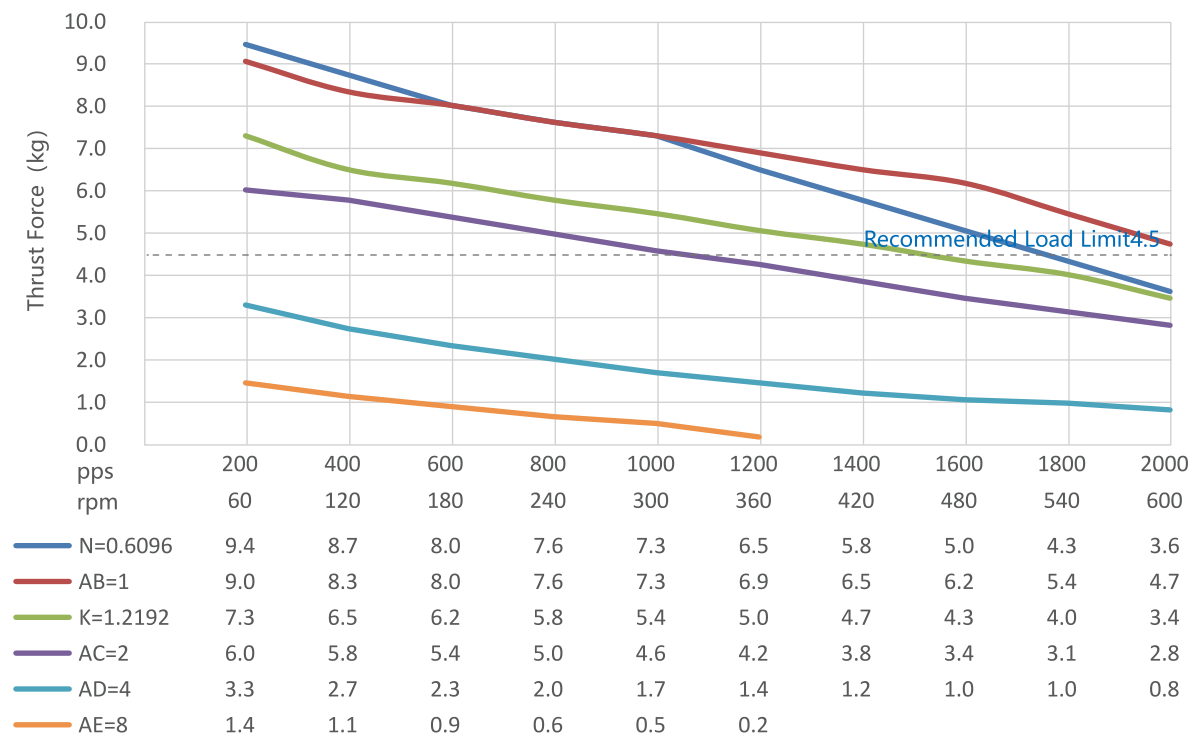

28mm(Size11) Linear Actuator , Single Stack

The 28mm(size 11) series Linear Actuator are available in three designs, captive, non-captive and external, with leads from 0.635mm to 10.16mm. Maximum thrust force is up to 15kg.



Electrical Parameter

Size 11: 28mm (1.1") Hybrid Linear Motor (1.8°Step Angle)			
Part No.	captive	28C1*	
	non-captive	28N1*	
	external	28E1*	
Wiring		Bipolar	
Wiring Voltage	2.1VDC	5VDC	12VDC
Current/Phase	1.0A	0.42A	0.18A
Resistance/Phase	2.1Ω	11.9Ω	66Ω
Inductance/Phase	1.5mH	8.5mH	50.3mH
Power Consumption/Total	4.2W		
Rotor Inertia	9.0gcm ²		
Temperature Rise	135°F (75°C)		
Insulation Class	Class B (Class F optional)		
Weight	119g		
Insulation Resistance	20MΩ		

Linear Travel/Strp (mm)	Lead (mm)	Lead Code
0.003175	0.635	D
0.00635	1.27	F
0.0127	2.54	L
0.0254	5.08	M
0.0508	10.16	W

Outline

Captive

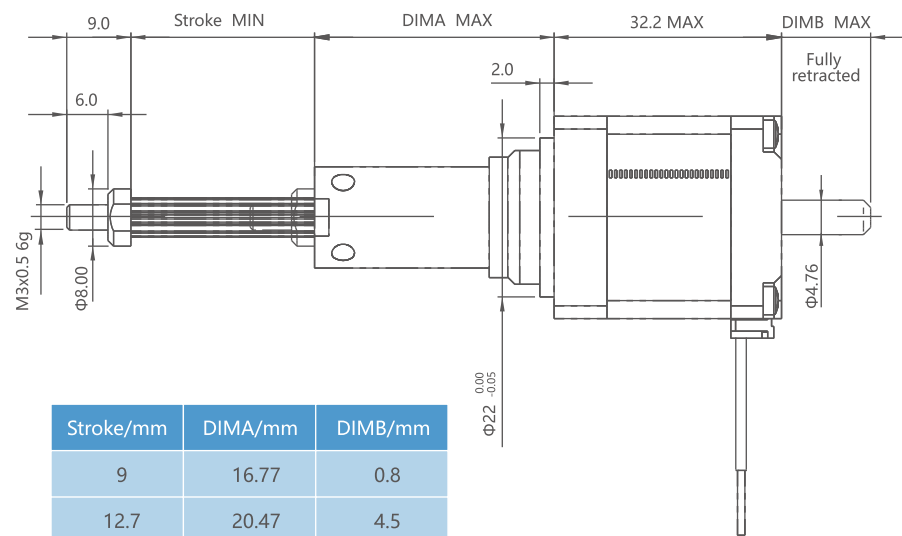

Stroke/mm	DIMA/mm	DIMB/mm
9	16.77	0.8
12.7	20.47	4.5
19.1	26.87	10.9
25.4	33.17	17.2
31.8	39.57	23.6
38.1	45.87	29.9
50.8	58.57	42.6

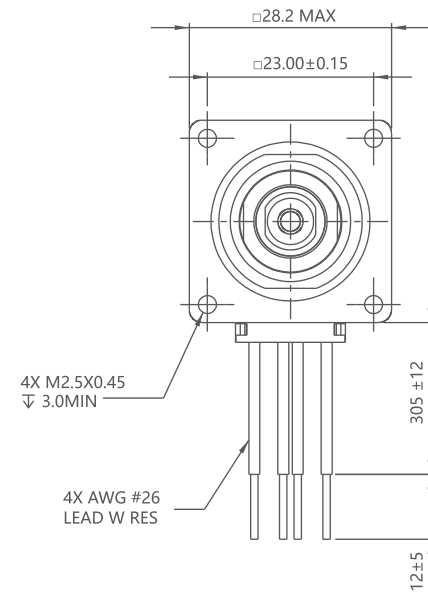

External

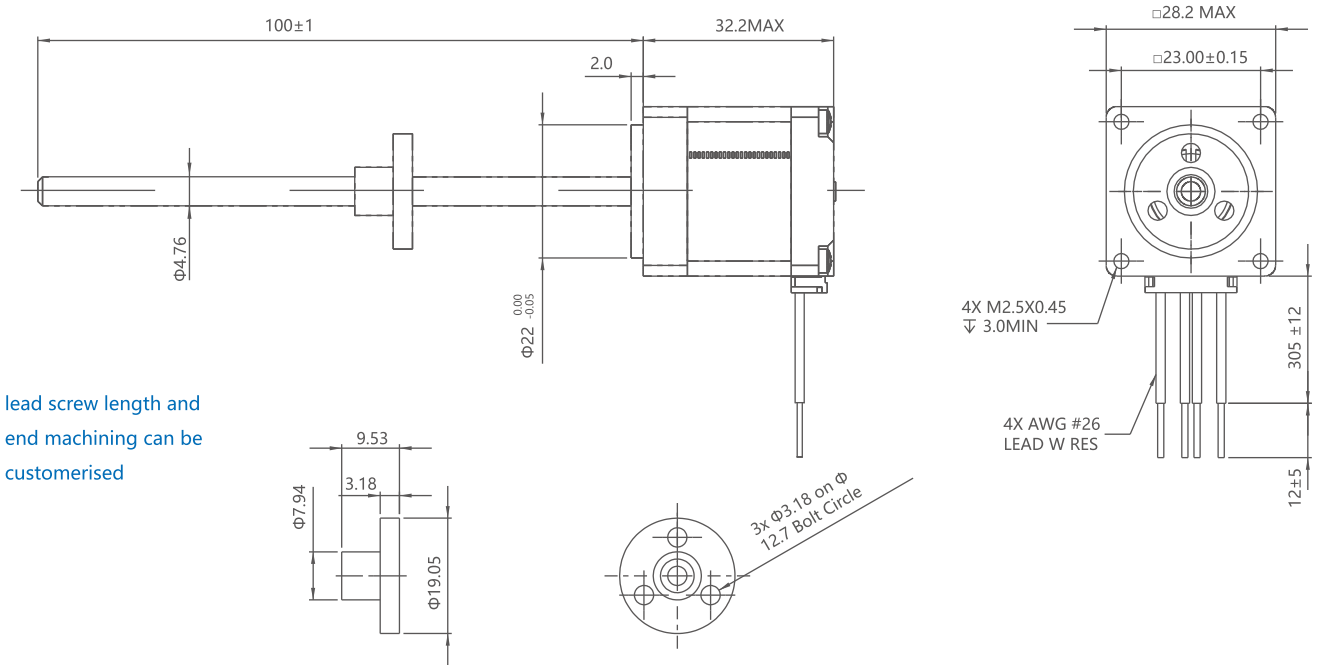

lead screw length and end machining can be customised

Non-captive

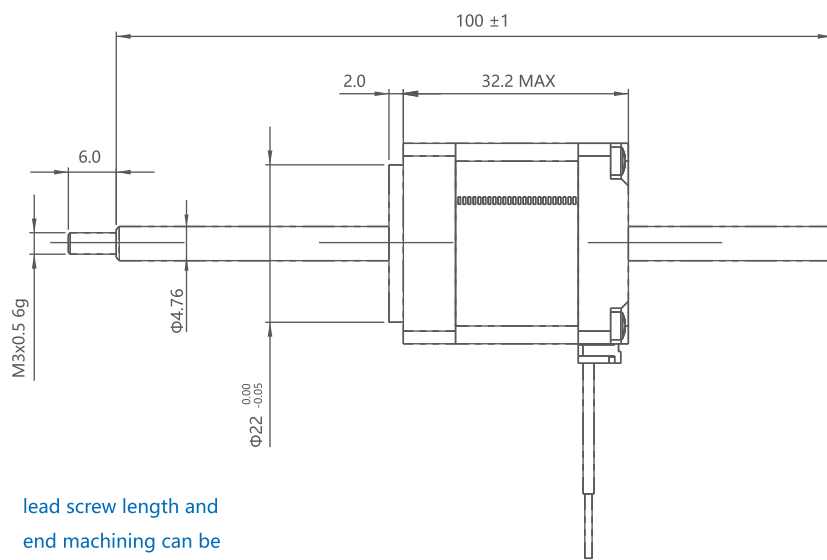

lead screw length and end machining can be customised

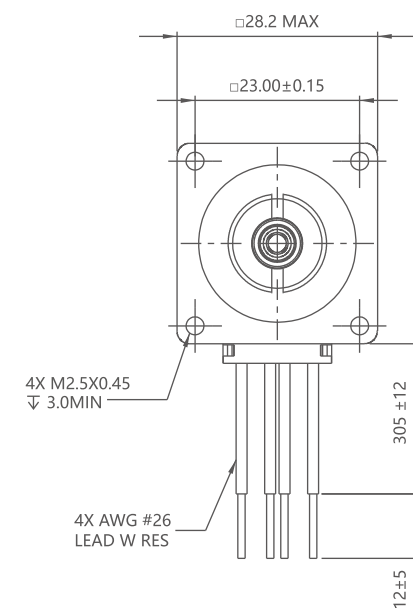

Force vs Pulse Curve

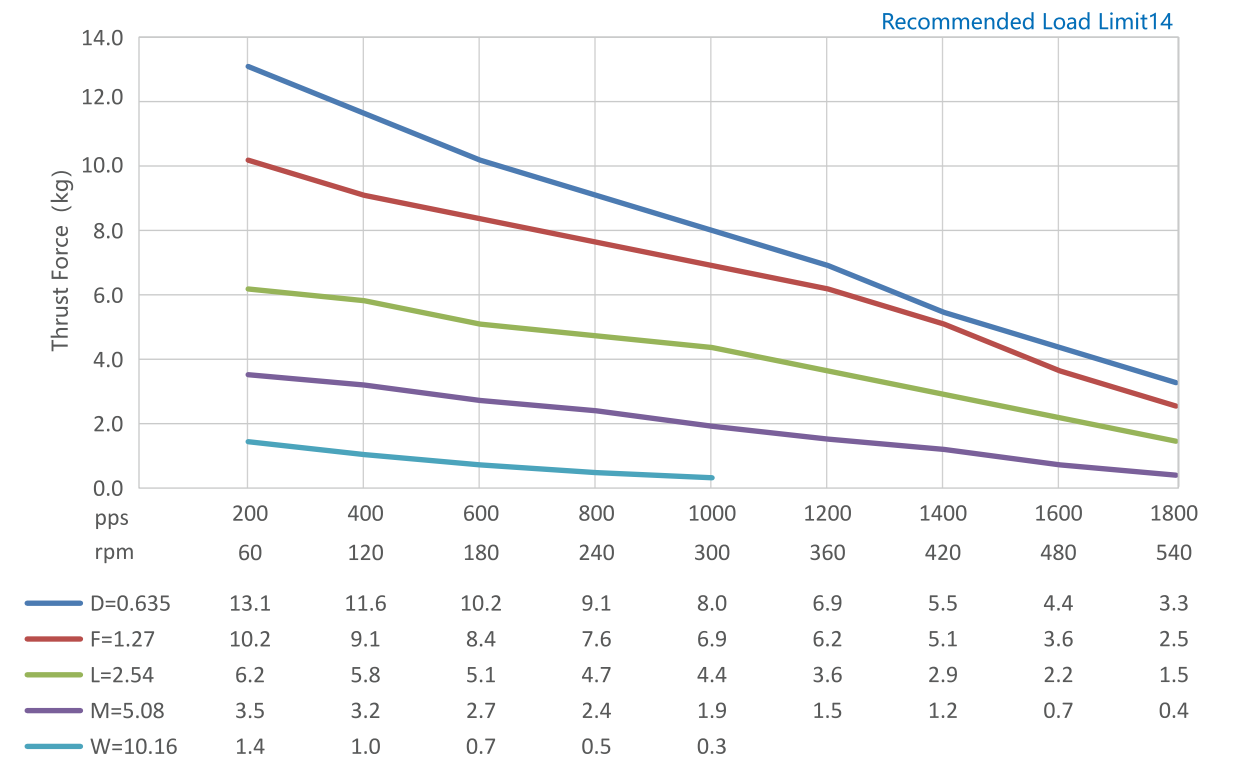

28mm(Size11) Linear Actuator , Double Stack

The 28mm(size 11) series Linear Actuator are available in three designs, captive, non-captive and external, with leads from 0.635mm to 10.16mm. Maximum thrust force is up to 15kg.



Electrical Parameter

Size 11: 28mm (1.1") Hybrid Linear Motor (1.8°Step Angle)			
Part No.	captive	28C2*	
	non-captive	28N2*	
	external	28E2*	
Wiring	Bipolar		
Wiring Voltage	2.1VDC	5VDC	12VDC
Current/Phase	1.9A	0.75A	0.35A
Resistance/Phase	1.2Ω	6.7Ω	34.8Ω
Inductance/Phase	1.0mH	5.8mH	35.6mH
Power Consumption/Total	7.5W		
Rotor Inertia	18gcm ²		
Temperature Rise	135°F (75°C)		
Insulation Class	Class B (Class F optional)		
Weight	180g		
Insulation Resistance	20MΩ		

Linear Travel/Strp (mm)	Lead (mm)	Lead Code
0.003175	0.635	D
0.00635	1.27	F
0.0127	2.54	L
0.0254	5.08	M
0.0508	10.16	W

Outline

Captive

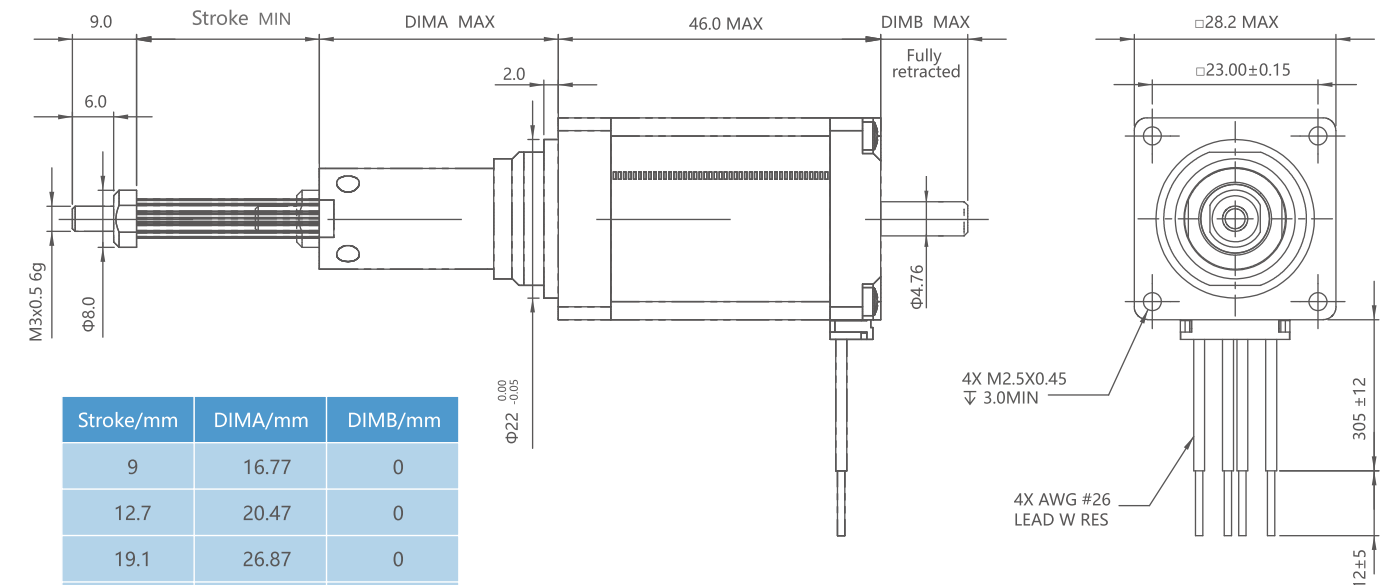

Stroke/mm	DIMA/mm	DIMB/mm
9	16.77	0
12.7	20.47	0
19.1	26.87	0
25.4	33.17	3.9
31.8	39.57	10.3
38.1	45.87	16.6
50.8	58.57	29.3

Non-captive

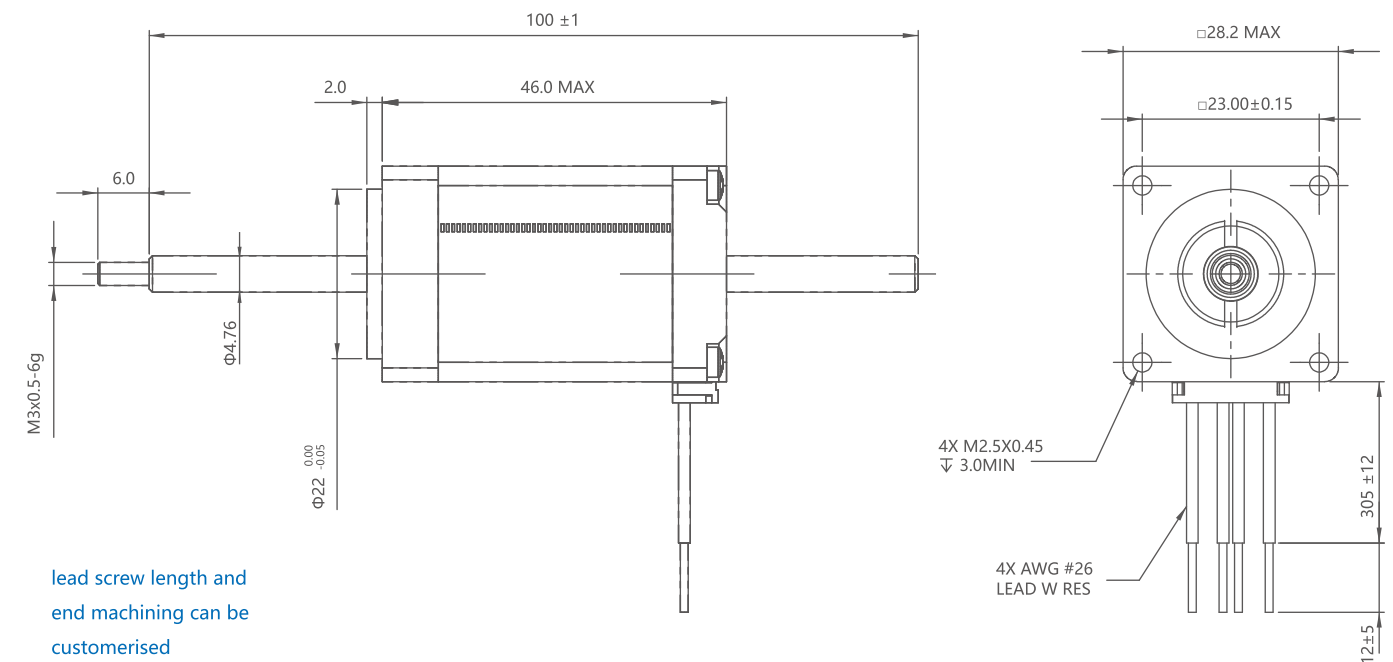

lead screw length and end machining can be customised

External

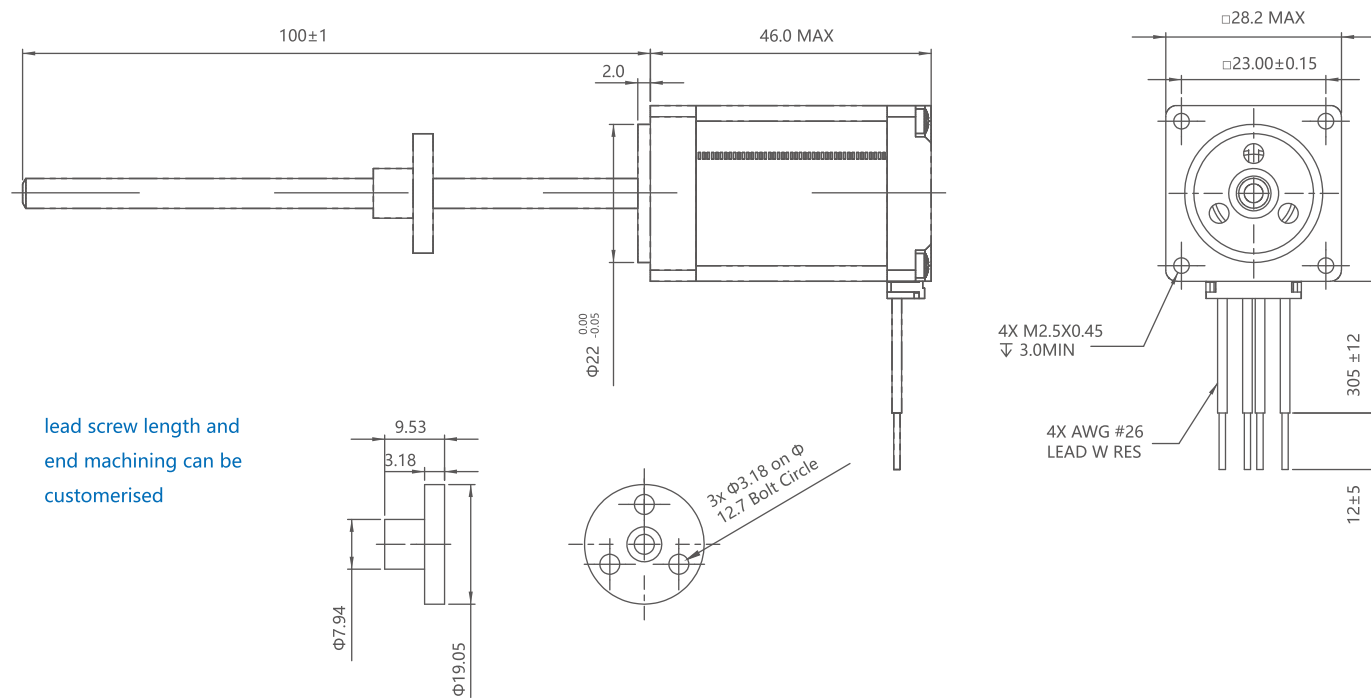

lead screw length and end machining can be customised

35mm(Size14) Linear Actuator , Single Stack

The 35mm(size 14) series Linear Actuator are available in three designs, captive, non-captive and external, with leads from 0.6096mm to 25.4mm. Maximum thrust force is up to 30kg.

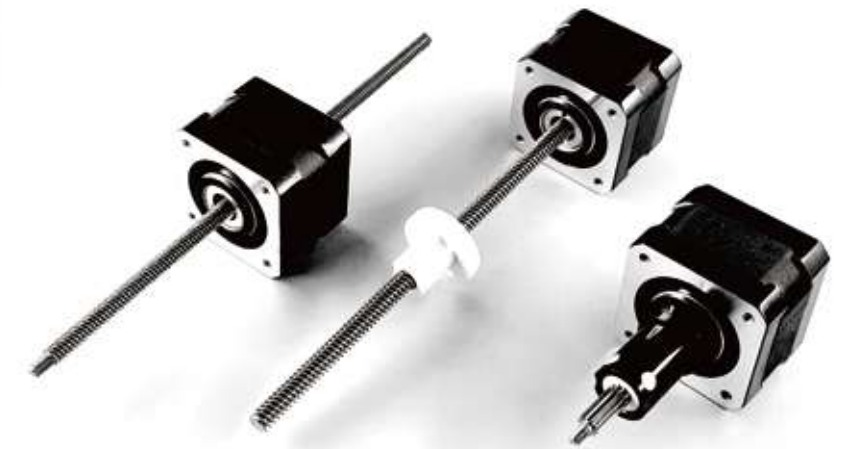

Force vs Pulse Curve

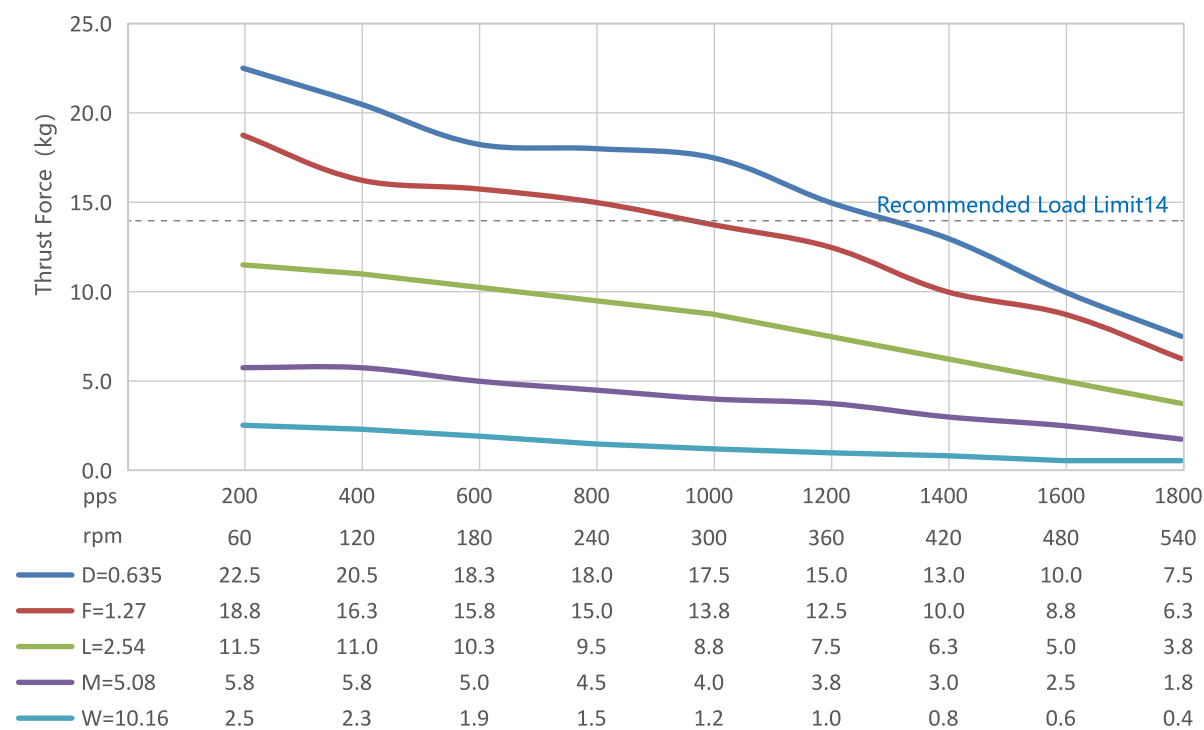

Electrical Parameter

Size 14: 35mm (1.4") Hybrid Linear Motor (1.8°Step Angle)			
Part No.	captive	35C1*	
	non-captive	35N1*	
	external	35E1*	
Wiring	Bipolar		
Wiring Voltage	2.33VDC	5VDC	12VDC
Current/Phase	1.25A	0.57A	0.24A
Resistance/Phase	1.86Ω	8.8Ω	50.5Ω
Inductance/Phase	3.0mH	14mH	66mH
Power Consumption/Total	5.7W		
Rotor Inertia	16gcm ²		
Temperature Rise	135°F (75°C)		
Insulation Class	Class B (Class F optional)		
Weight	162g		
Insulation Resistance	20MΩ		

Linear Travel/Strp (mm)	Lead (mm)	Lead Code
0.00396875	0.79375	P
0.00635	1.27	F
0.0079375	1.5875	A
0.0127	2.54	L
0.015875	3.175	B
0.254	5.08	M
0.3175	6.35	C
0.0635	12.7	Y
0.127	25.4	Z

Outline

Captive

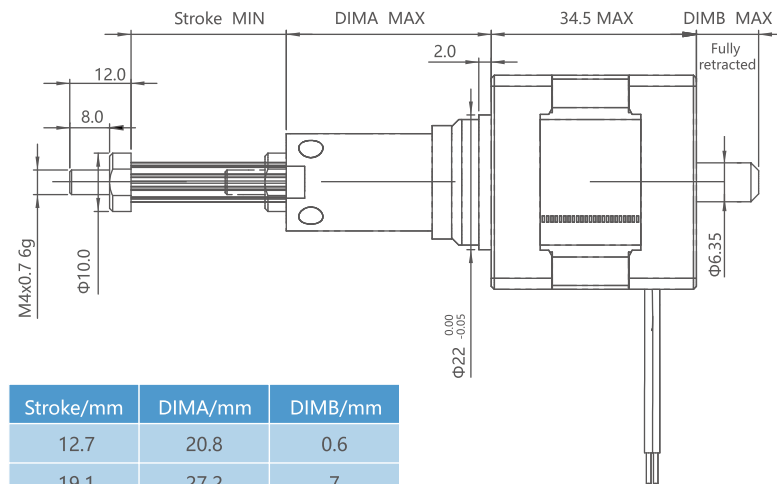

Stroke/mm	DIMA/mm	DIMB/mm
12.7	20.8	0.6
19.1	27.2	7
25.4	33.5	13.3
31.8	39.9	19.7
38.1	46.2	26
50.8	58.9	38.7
63.5	71.6	51.4

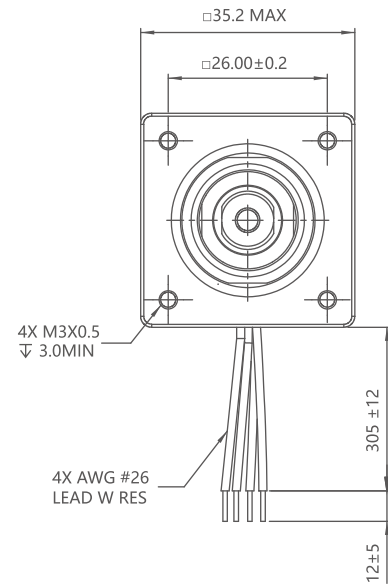

External

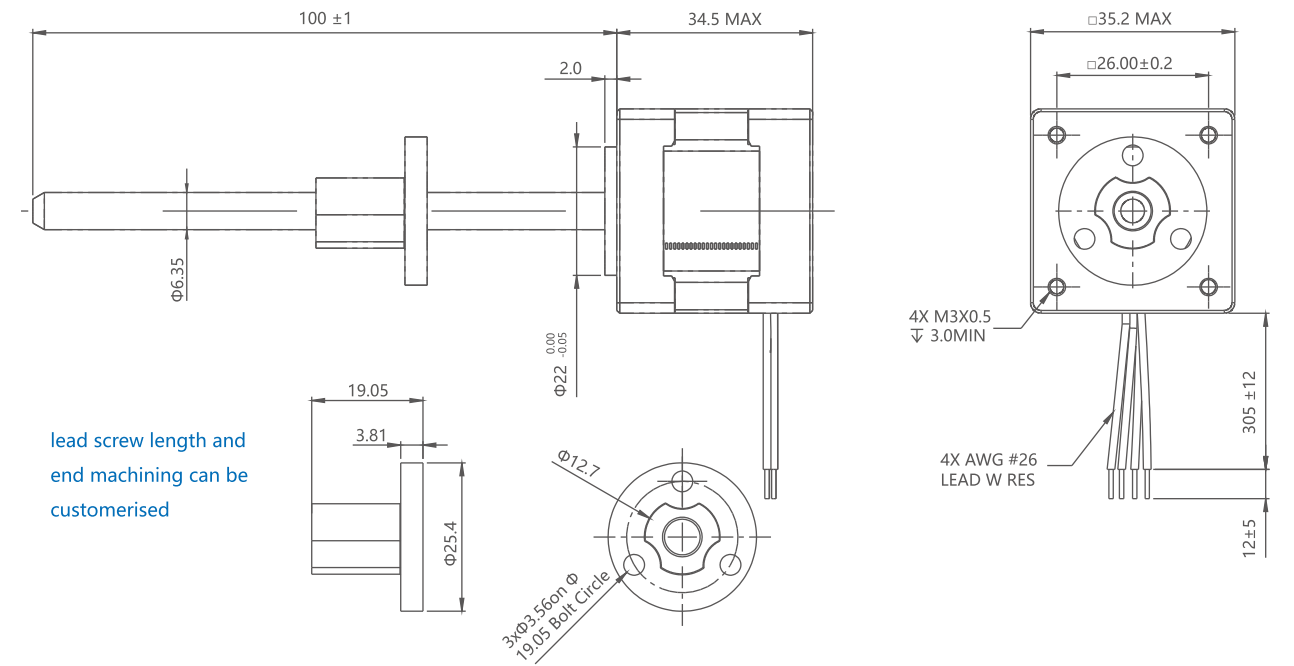

lead screw length and end machining can be customised

Force vs Pulse Curve

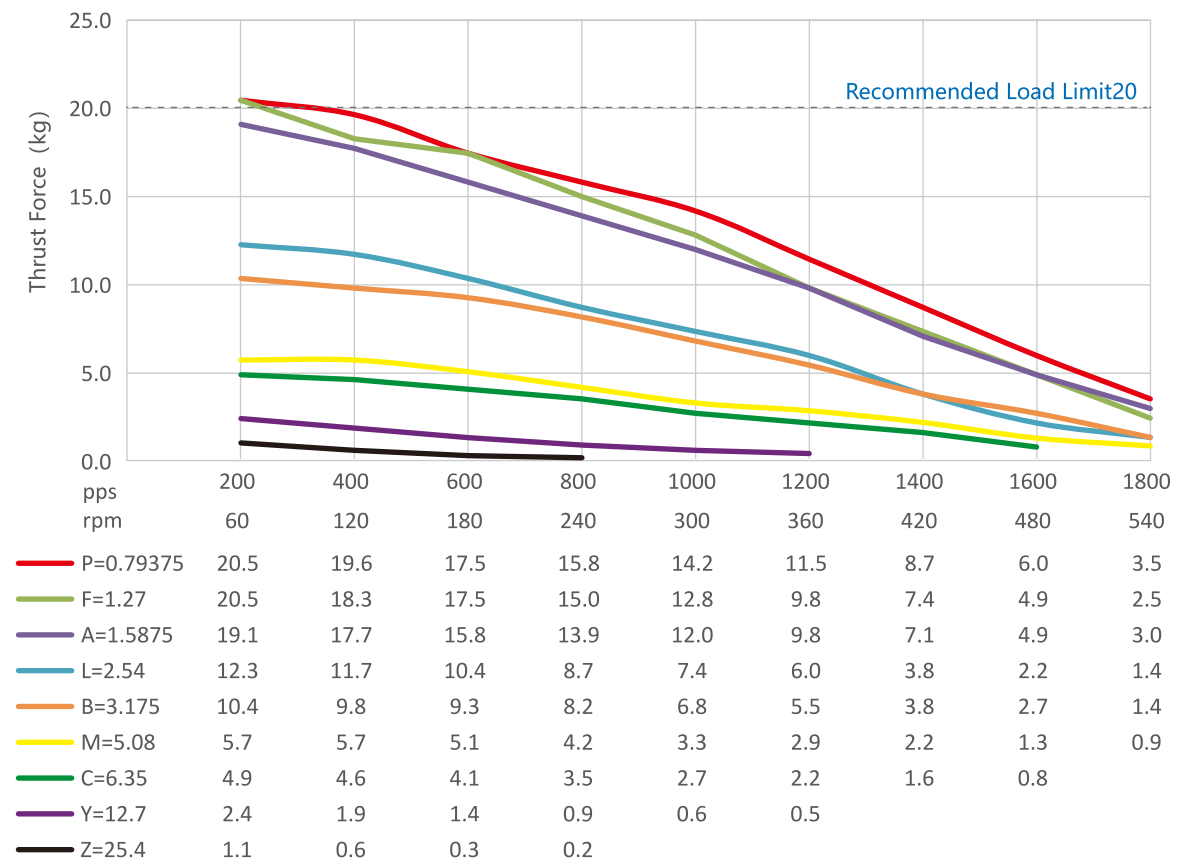

Non-captive

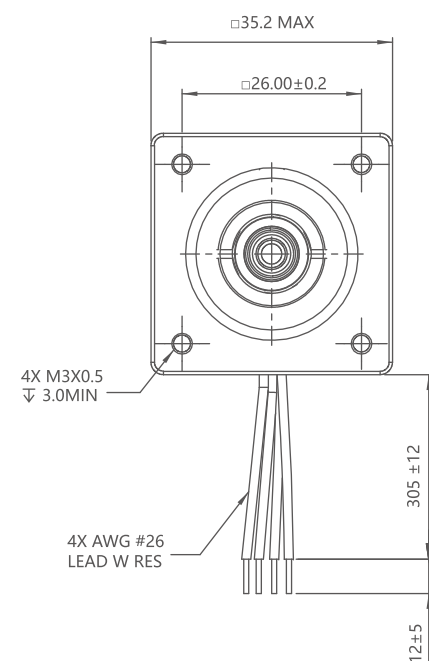
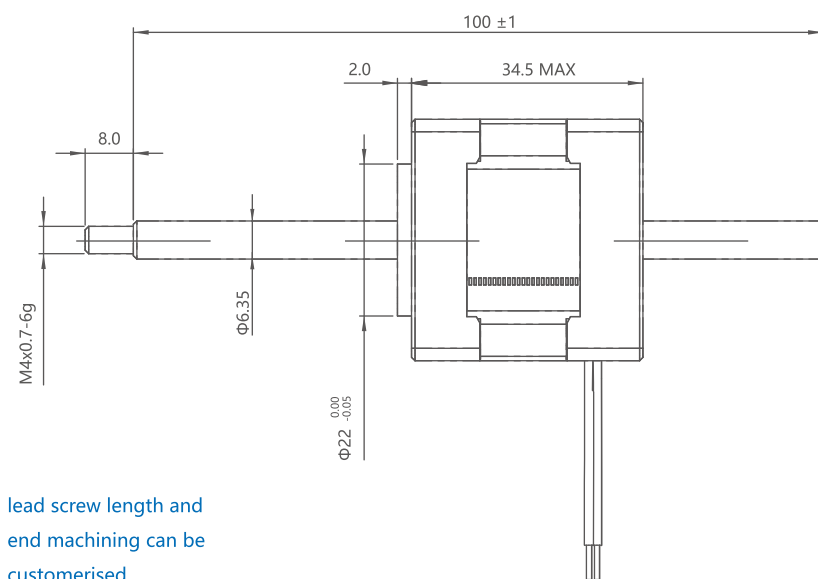

lead screw length and end machining can be customised

35mm(Size14) Linear Actuator , Double Stack

The 35mm(size 14) series Linear Actuator are available in three designs, captive, non-captive and external, with leads from 0.6096mm to 25.4mm. Maximum thrust force is up to 30kg.



Electrical Parameter

Size 14: 35mm (1.4") Hybrid Linear Motor (1.8°Step Angle)			
Part No.	captive	35C2*	
	non-captive	35N2*	
	external	35E2*	
Wiring	Bipolar		
Wiring Voltage	2.33VDC	5VDC	12VDC
Current/Phase	2A	0.91A	0.38A
Resistance/Phase	1.2Ω	5.5Ω	31.6Ω
Inductance/Phase	1.95mH	7.63mH	65.1mH
Power Consumption/Total	9.1W		
Rotor Inertia	30gcm ²		
Temperature Rise	135°F (75°C)		
Insulation Class	Class B (Class F optional)		
Weight	240g		
Insulation Resistance	20MΩ		

Linear Travel/Strp (mm)	Lead (mm)	Lead Code
0.015875	3.175	B
0.254	5.08	M
0.3175	6.35	C
0.0635	12.7	Y
0.127	25.4	Z

Outline

Captive

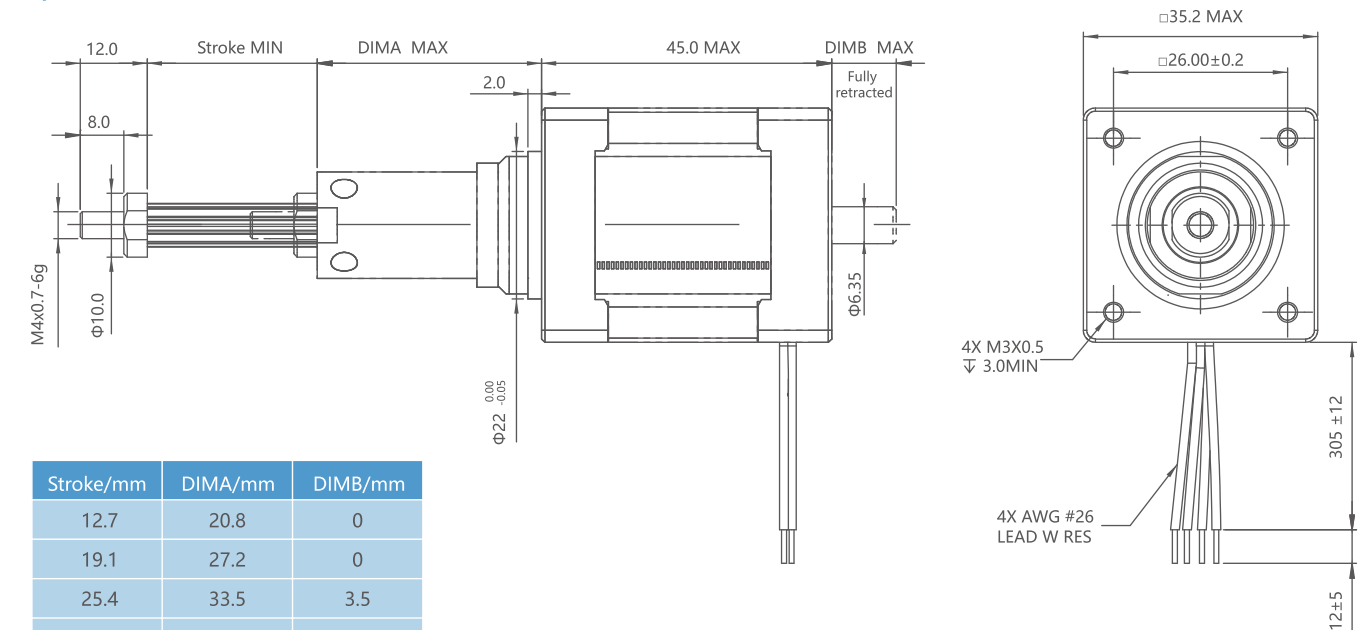

Stroke/mm	DIMA/mm	DIMB/mm
12.7	20.8	0
19.1	27.2	0
25.4	33.5	3.5
31.8	39.9	9.9
38.1	46.2	16.2
50.8	58.9	28.9
63.5	71.6	41.6

Non-captive

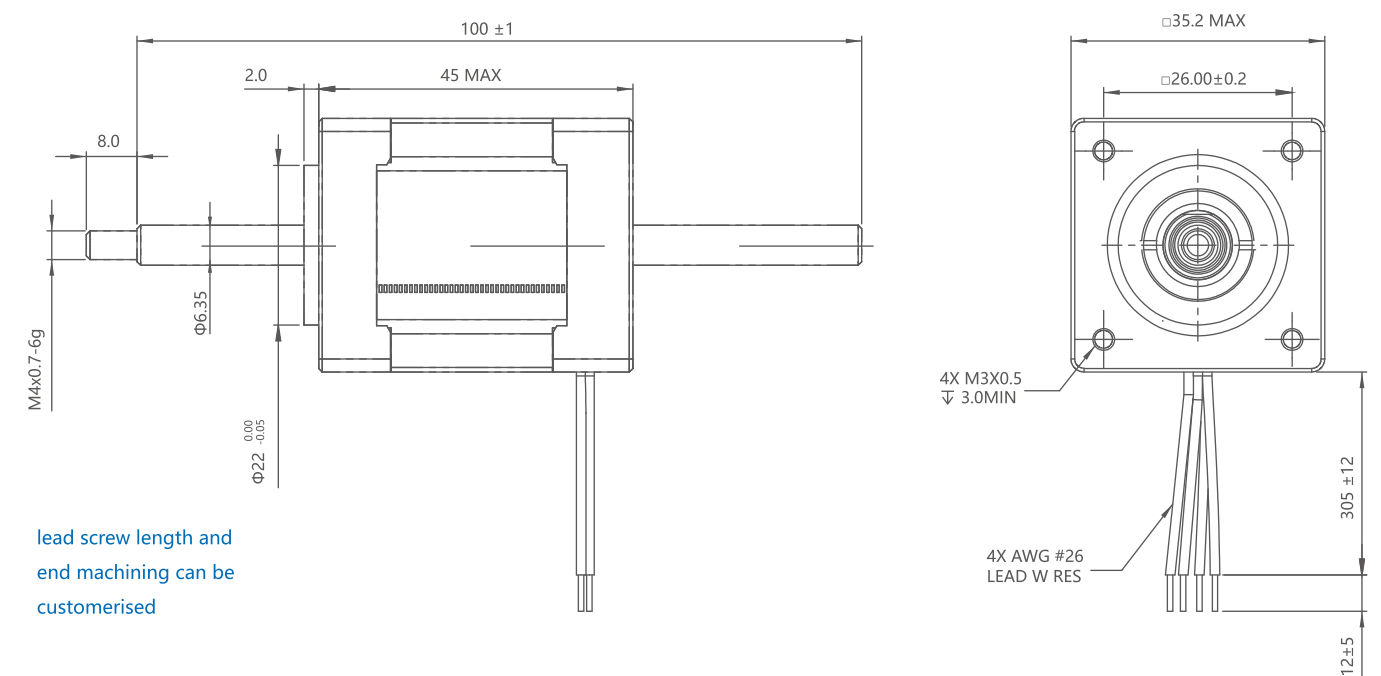

lead screw length and end machining can be customised

External

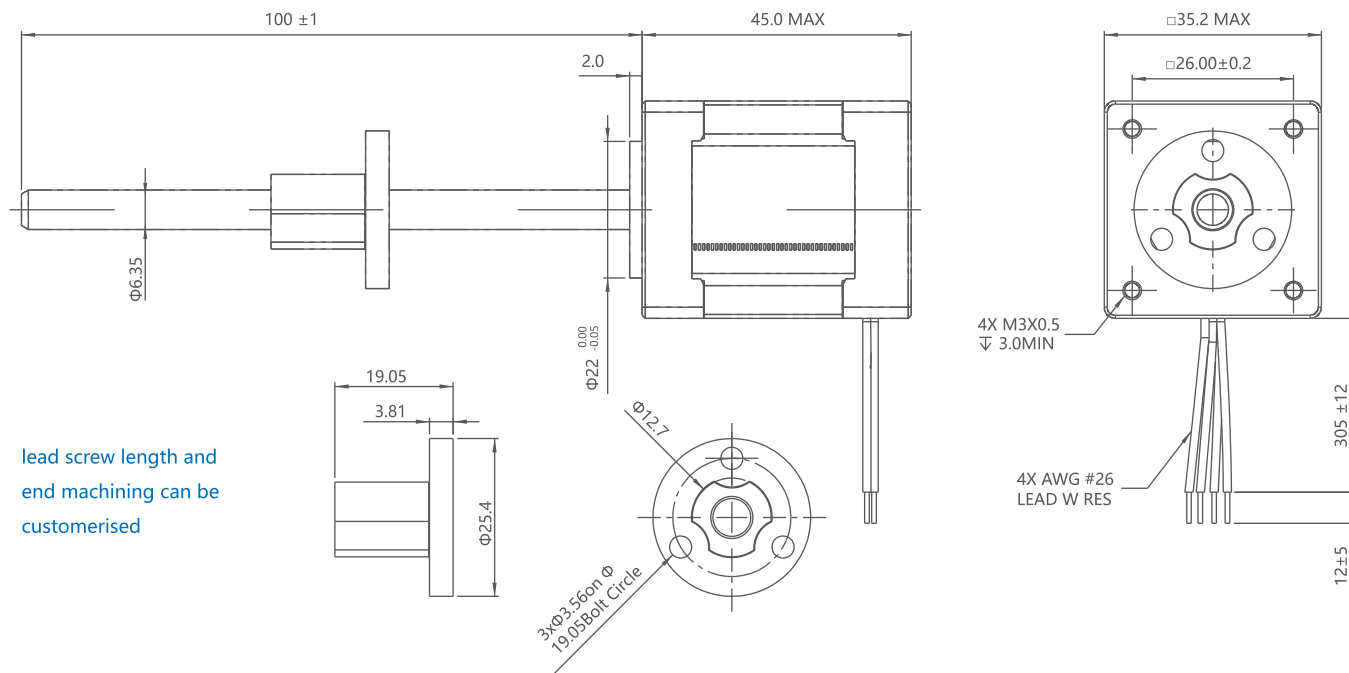

lead screw length and end machining can be customised

42mm(Size17) Linear Actuator , Single Stack

The 42mm(size 17) series Linear Actuator are available in three designs, captive, non-captive and external, with leads from 0.6096mm to 25.4mm. Maximum thrust force is up to 45kg.

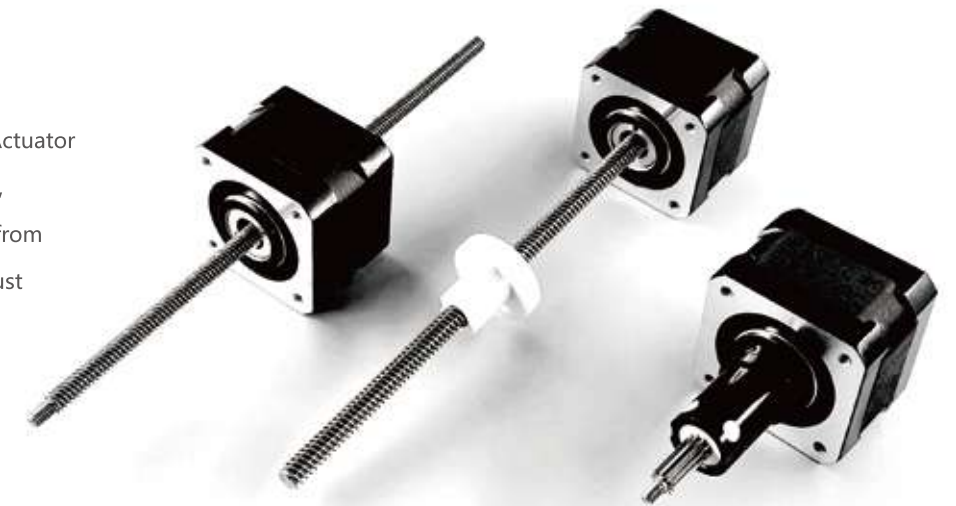

Force vs Pulse Curve

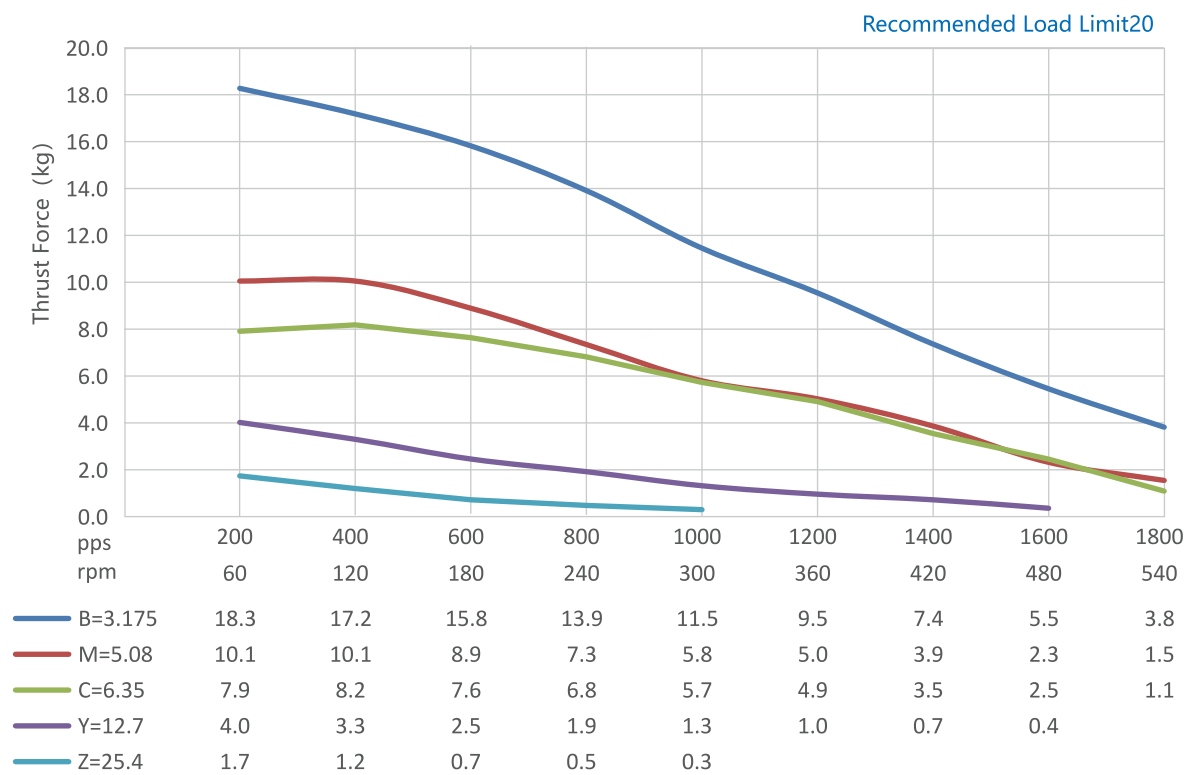

Electrical Parameter

Size 17: 42mm (1.7") Hybrid Linear Motor (1.8°Step Angle)			
Part No.	captive	42C1*	
	non-captive	42N1*	
	external	42E1*	
Wiring		Bipolar	
Wiring Voltage	2.33VDC	5VDC	12VDC
Current/Phase	1.5A	0.7A	0.29A
Resistance/Phase	1.56Ω	7.2Ω	41.5Ω
Inductance/Phase	1.9mH	9.5mH	54.0mH
Power Consumption/Total	7W		
Rotor Inertia	37gcm ²		
Temperature Rise	135°F (75°C)		
Insulation Class	Class B (Class F optional)		
Weight	240g		
Insulation Resistance	20MΩ		

Linear Travel/Strp (mm)	Lead (mm)	Lead Code
0.00396875	0.79375	P
0.00635	1.27	F
0.0079375	1.5875	A
0.0127	2.54	L
0.015875	3.175	B
0.254	5.08	M
0.3175	6.35	C
0.0635	12.7	Y
0.127	25.4	Z

Outline

Captive

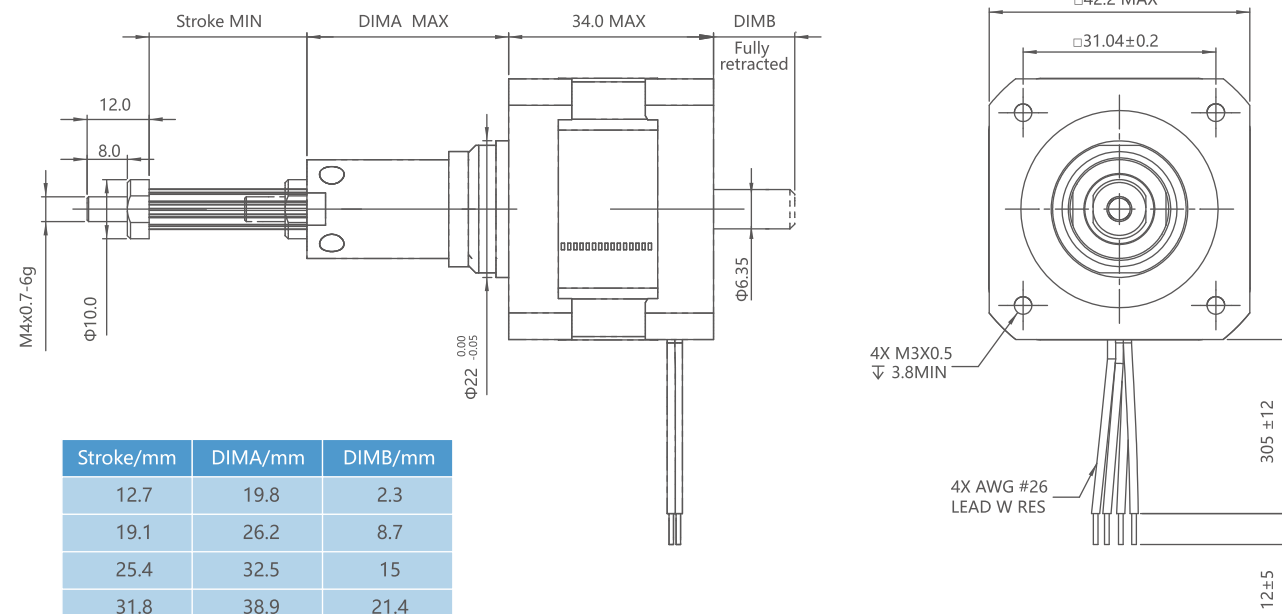

Stroke/mm	DIMA/mm	DIMB/mm
12.7	19.8	2.3
19.1	26.2	8.7
25.4	32.5	15
31.8	38.9	21.4
38.1	45.2	27.7
50.8	57.9	40.4
63.5	70.6	53.1

External

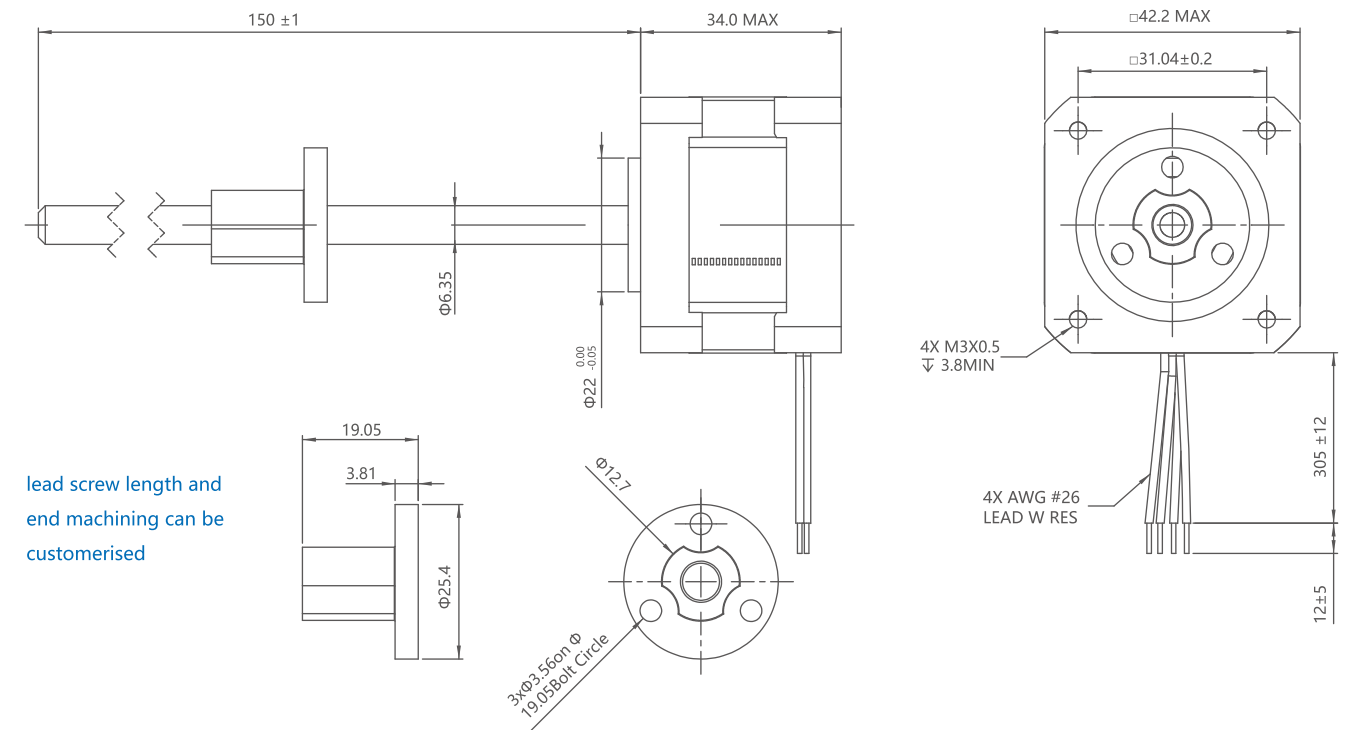

Non-captive

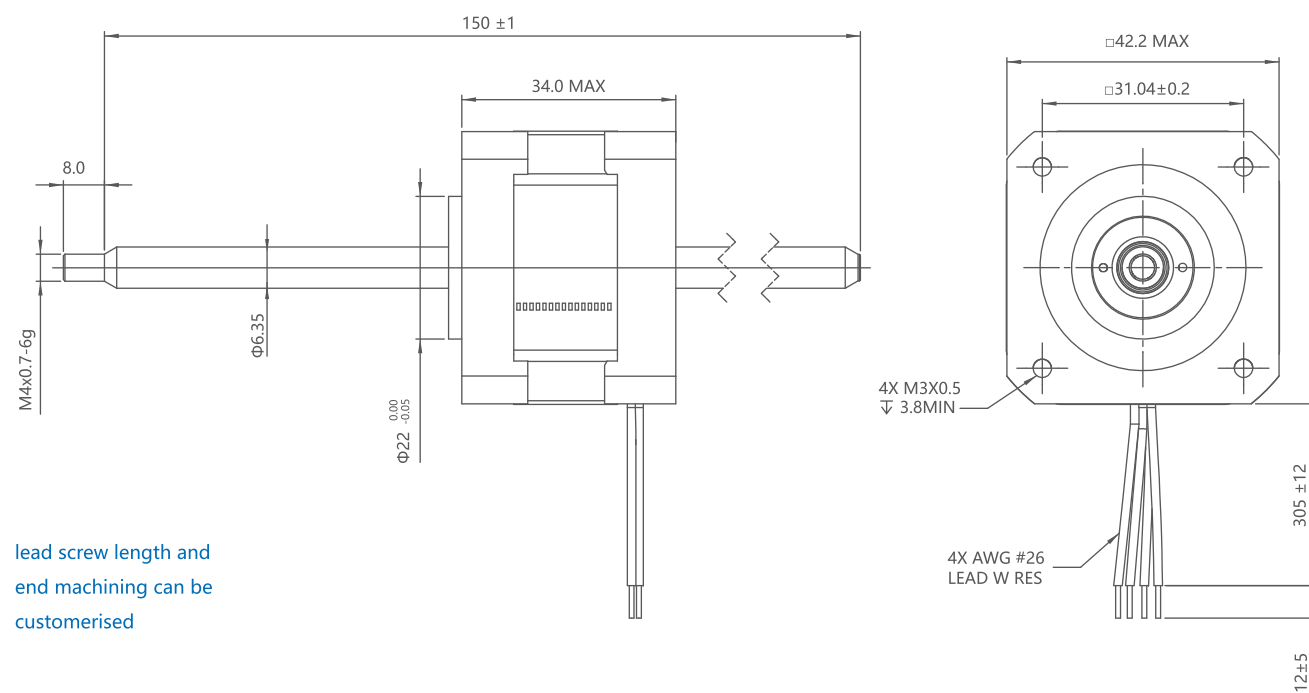

Force vs Pulse Curve

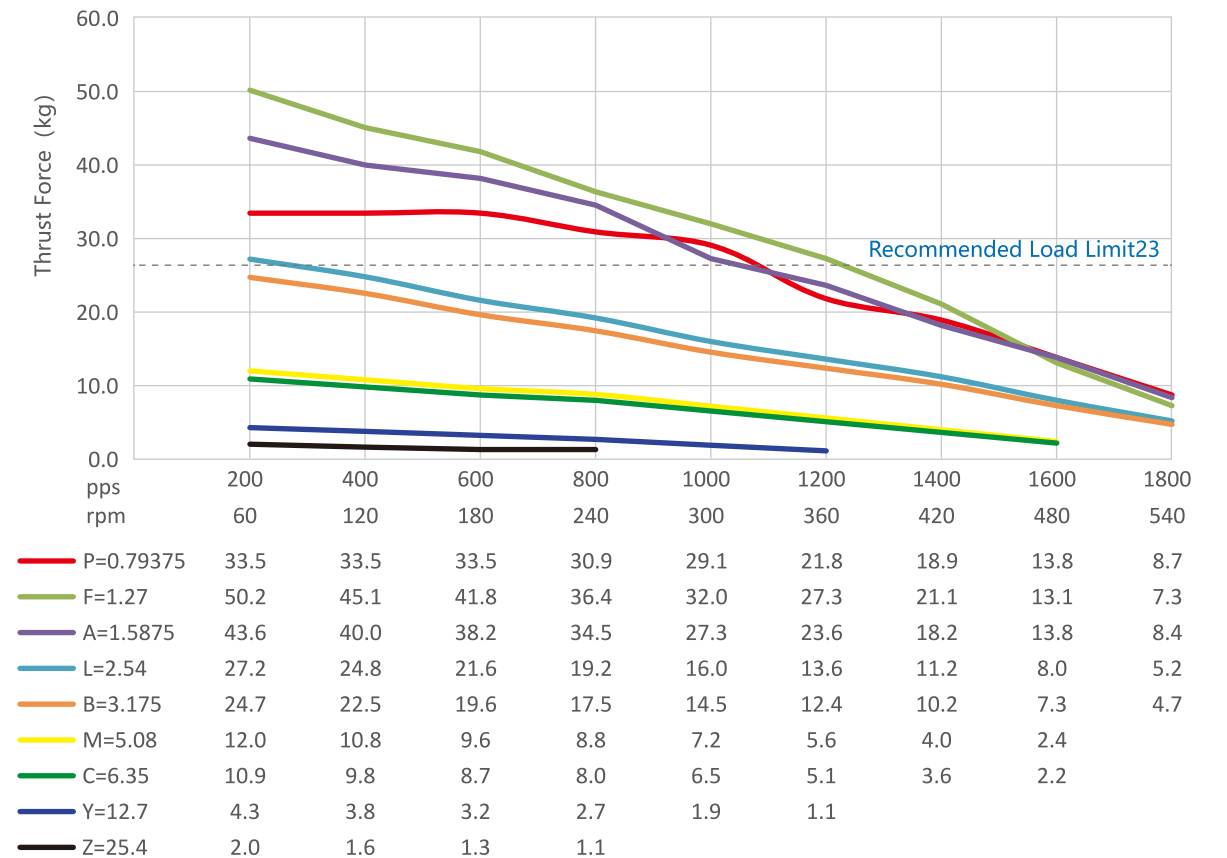

42mm(Size17) Linear Actuator , Double Stack

The 42mm(size 17) series Linear Actuator are available in three designs, captive, non-captive and external, with leads from 0.6096mm to 25.4mm. Maximum thrust force is up to 45kg.



Electrical Parameter

Size 17: 42mm (1.7") Hybrid Linear Motor (1.8°Step Angle)			
Part No.	captive	42C2*	
	non-captive	42N2*	
	external	42E2*	
Wiring	Bipolar		
Wiring Voltage	2.33VDC	5VDC	12VDC
Current/Phase	2.6A	1.3A	0.55A
Resistance/Phase	0.85Ω	3.8Ω	21.9Ω
Inductance/Phase	1.1mH	7.8mH	45.1mH
Power Consumption/Total	10.4W		
Rotor Inertia	78gcm ²		
Temperature Rise	135°F (75°C)		
Insulation Class	Class B (Class F optional)		
Weight	352g		
Insulation Resistance	20MΩ		

Linear Travel/Strp (mm)	Lead (mm)	Lead Code
0.015875	3.175	B
0.254	5.08	M
0.3175	6.35	C
0.0635	12.7	Y
0.127	25.4	Z

Outline

Captive

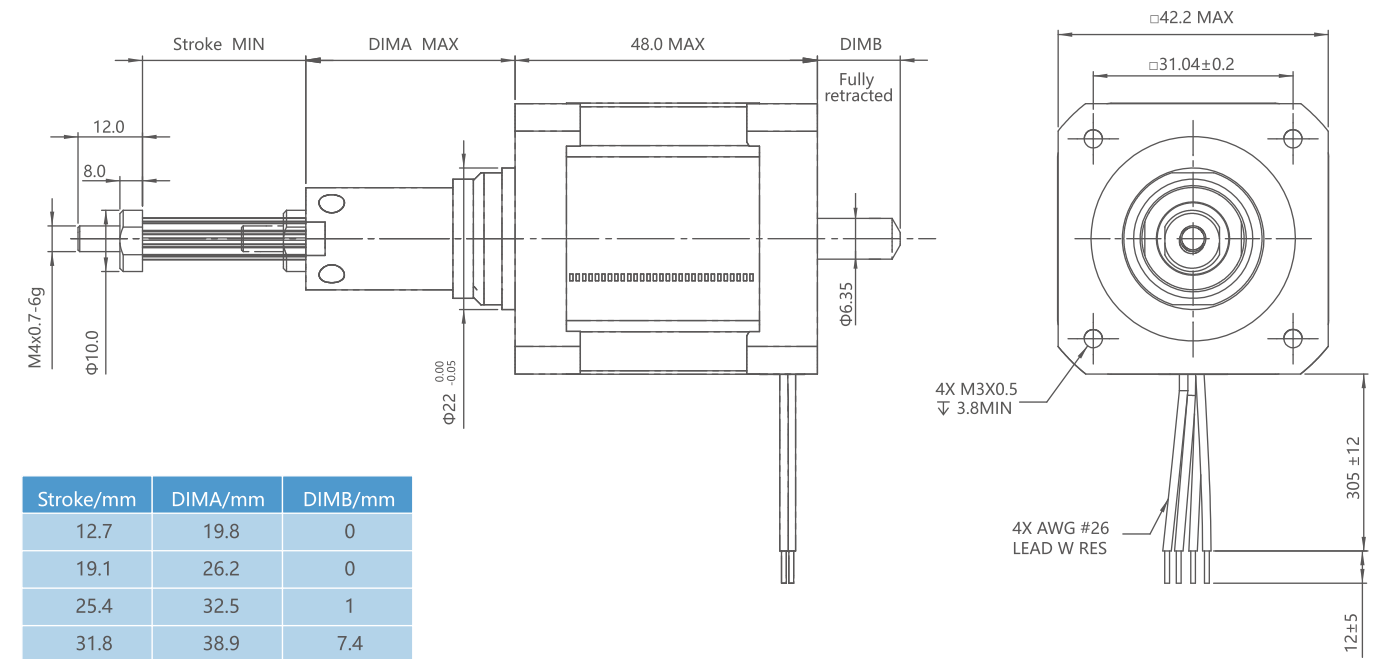

Stroke/mm	DIMA/mm	DIMB/mm
12.7	19.8	0
19.1	26.2	0
25.4	32.5	1
31.8	38.9	7.4
38.1	45.2	13.7
50.8	57.9	26.4
63.5	70.6	39.1

Non-captive

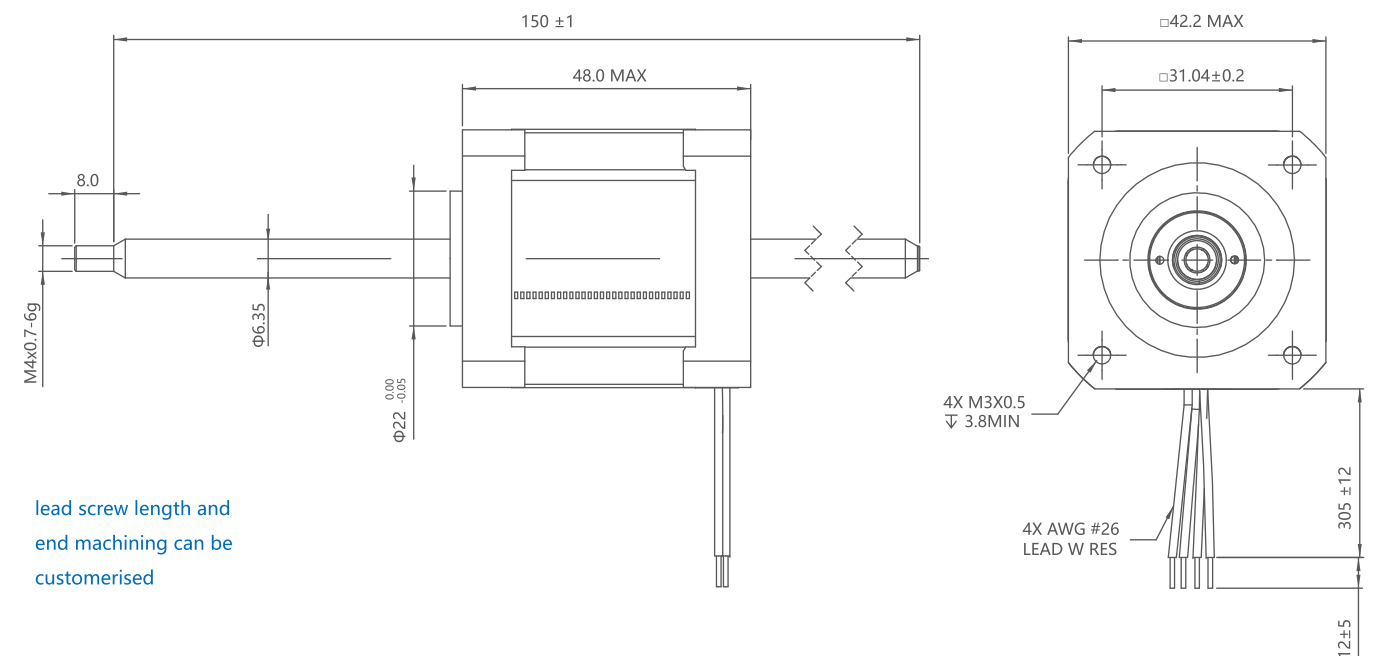

lead screw length and end machining can be customised

External

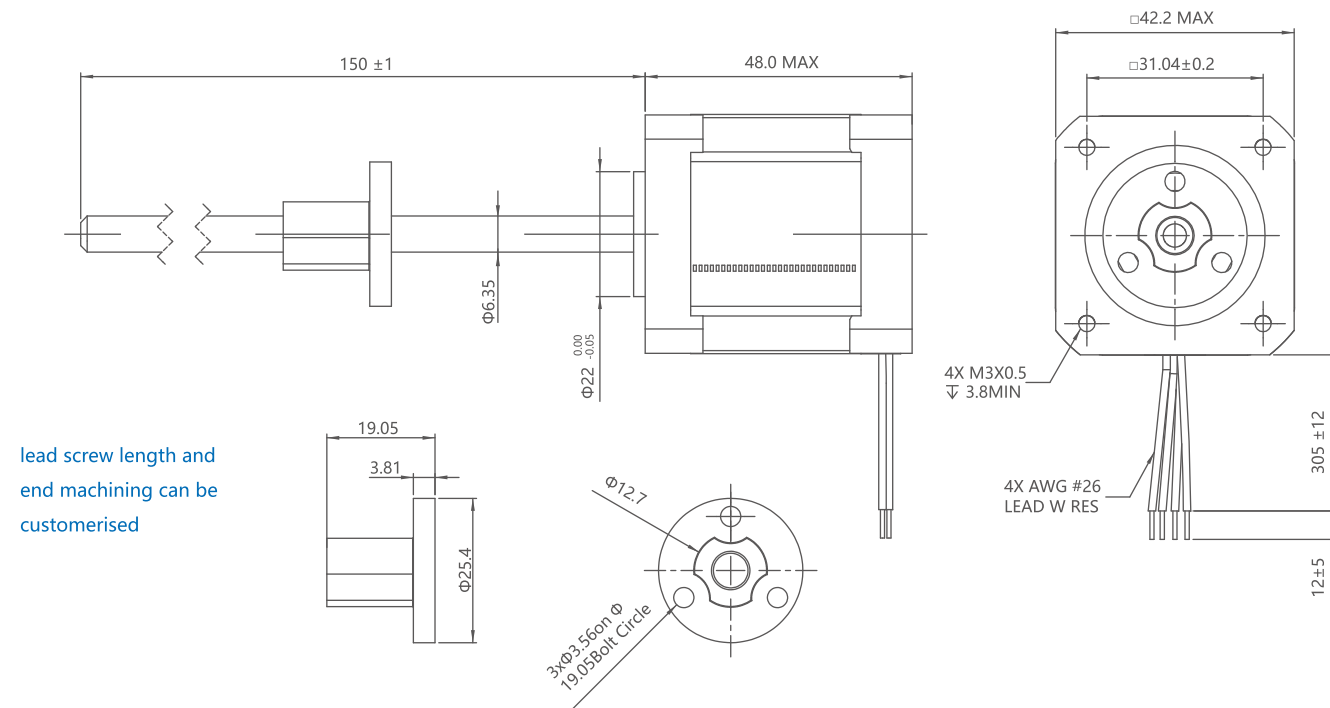

lead screw length and end machining can be customised

57mm(Size23) Linear Actuator , Single Stack

The 57mm(size 23) series Linear Actuator are available in three designs, captive, non-captive and external, with leads from 0.635mm to 25.4mm. Maximum thrust force is up to 90kg.

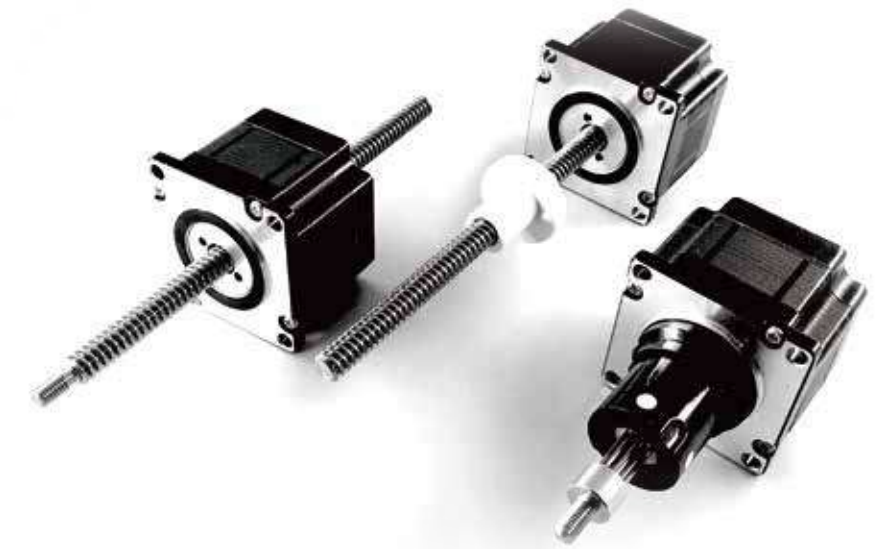

Force vs Pulse Curve

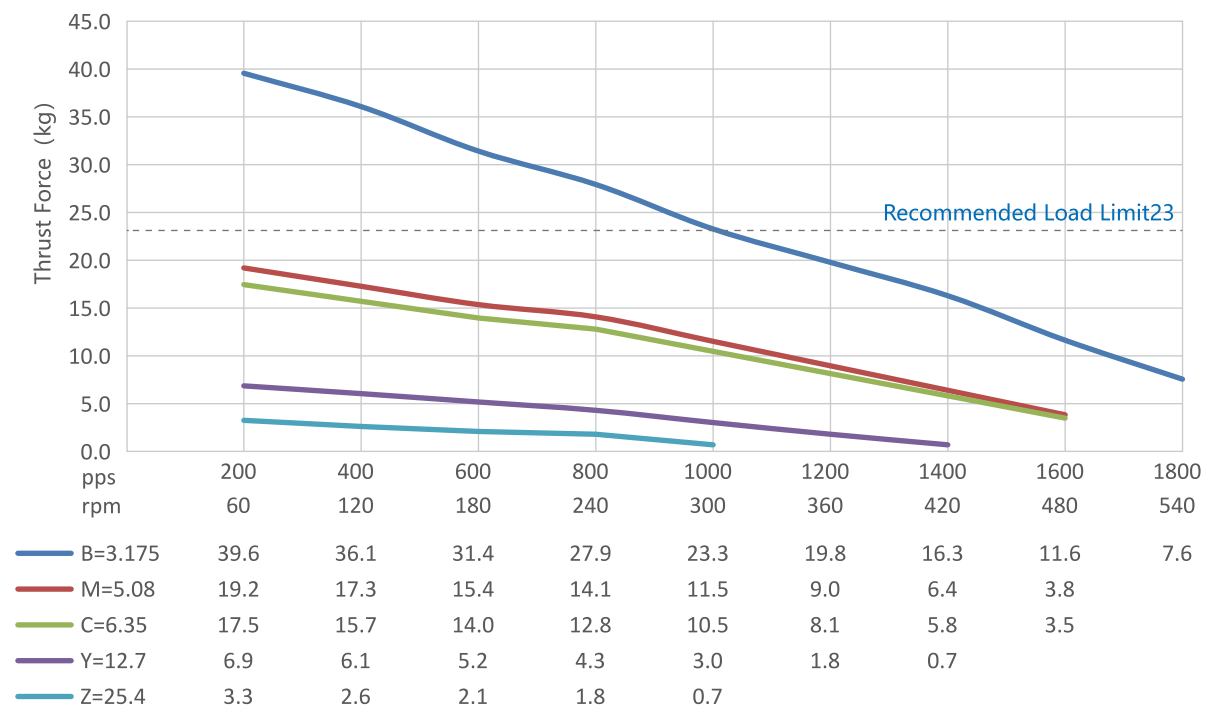

Electrical Parameter

Size 23: 57mm (2.3") Hybrid Linear Motor (1.8°Step Angle)			
Part No.	captive	57C1*	
	non-captive	57N1*	
	external	57E1*	
Wiring	Bipolar		
Wiring Voltage	3.25VDC	5VDC	12VDC
Current/Phase	2.0A	1.3A	0.55A
Resistance/Phase	1.6Ω	3.8Ω	22Ω
Inductance/Phase	3.5mH	15.5mH	58mH
Power Consumption/Total	13W		
Rotor Inertia	166gcm ²		
Temperature Rise	135°F (75°C)		
Insulation Class	Class B (Class F optional)		
Weight	511g		
Insulation Resistance	20MΩ		

Linear Travel/Strp (mm)	Lead (mm)	Lead Code
0.003175	0.635	D
0.00635	1.27	F
0.0079375	1.5875	A
0.0127	2.54	L
0.015875	3.175	B
0.254	5.08	M
0.3175	6.35	C
0.0508	10.16	W
0.0635	12.7	Y
0.127	25.4	Z

Outline

Captive

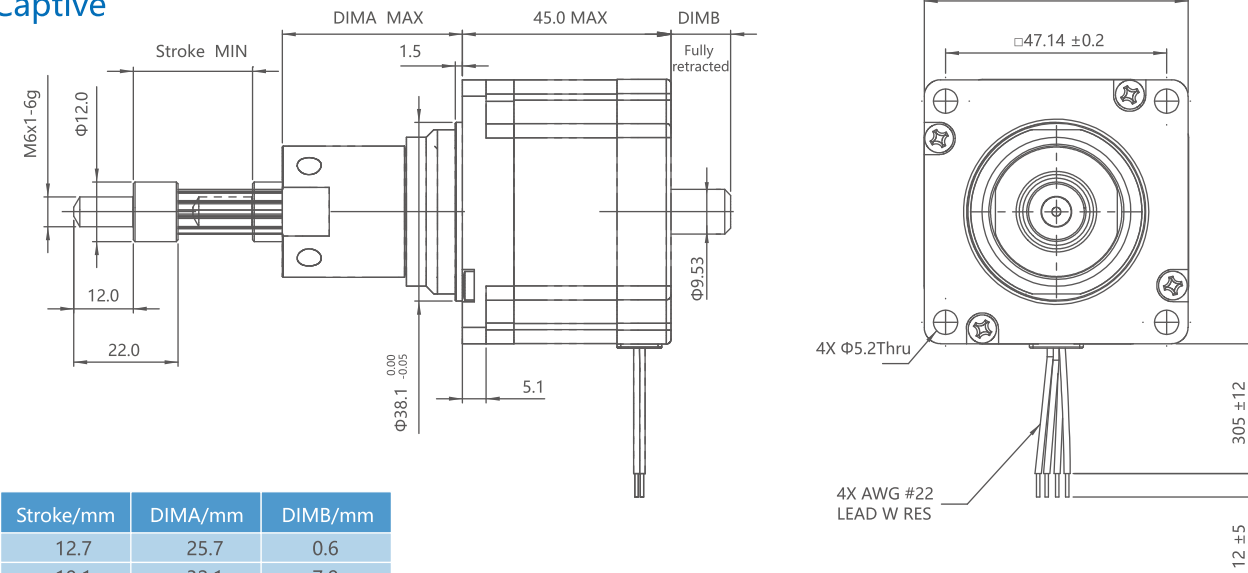

Stroke/mm	DIMA/mm	DIMB/mm
12.7	25.7	0.6
19.1	32.1	7.9
25.4	38.4	14.2
31.8	44.8	20.6
38.1	51.1	26.9
50.8	63.8	39.6
63.5	76.5	52.3

Non-captive

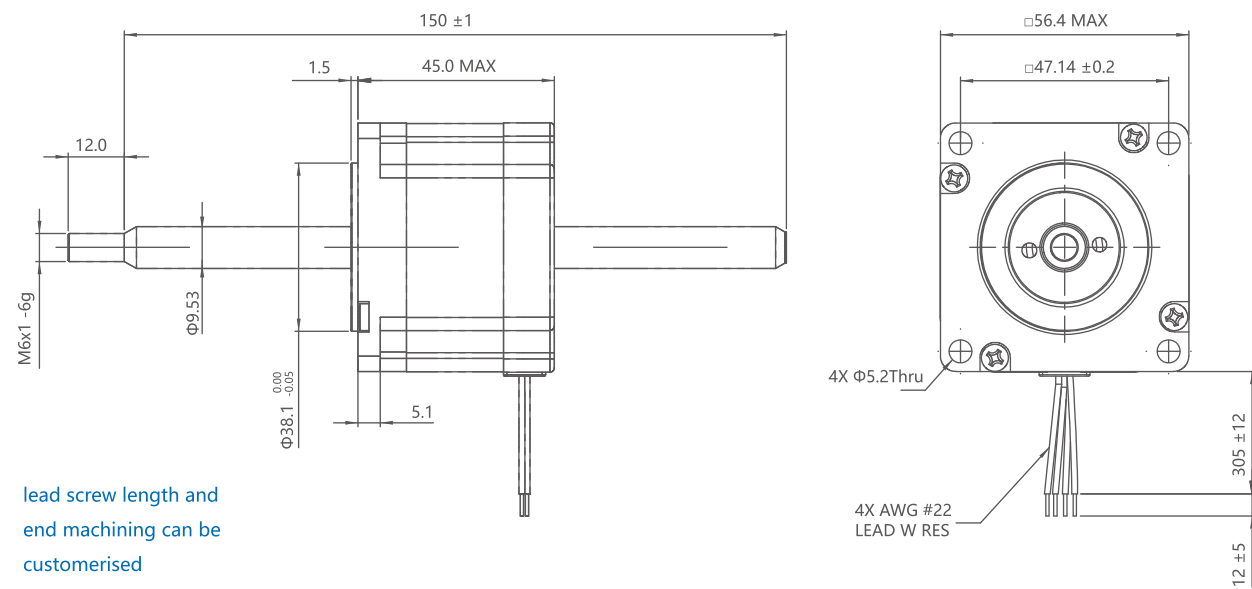

lead screw length and end machining can be customised

External

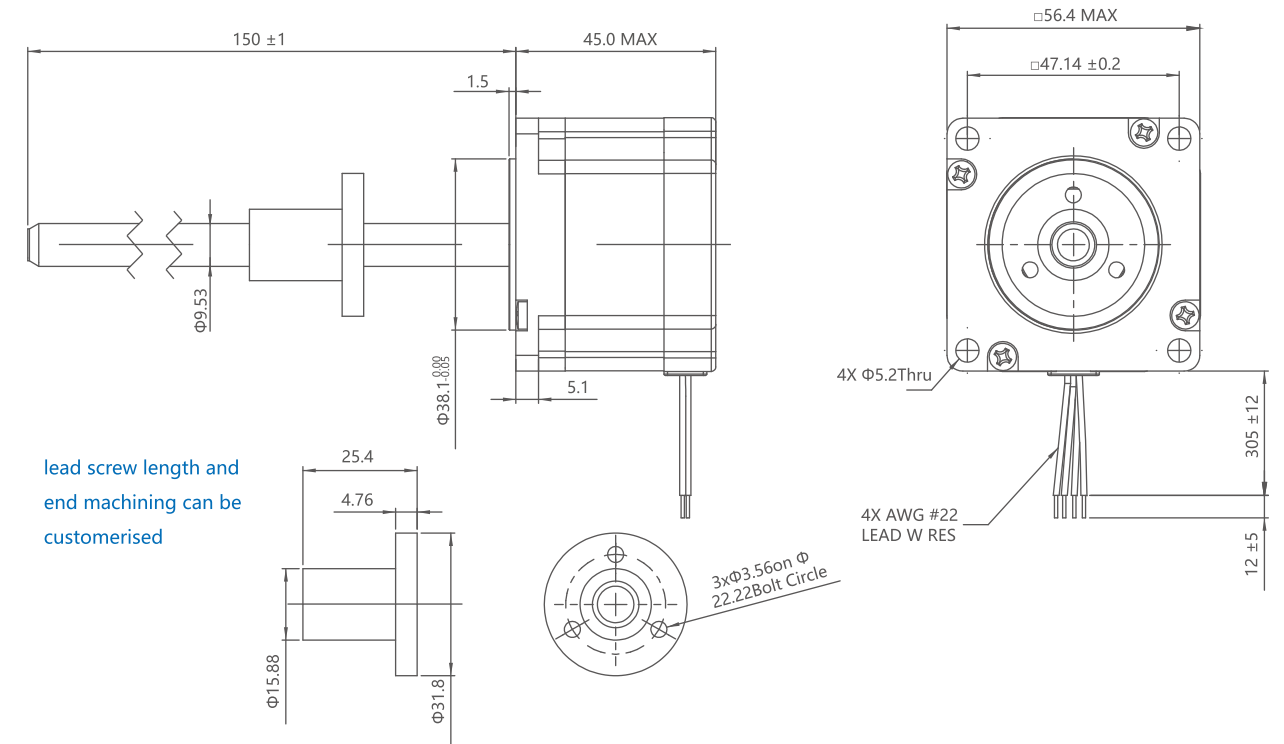

lead screw length and end machining can be customised

Force vs Pulse Curve

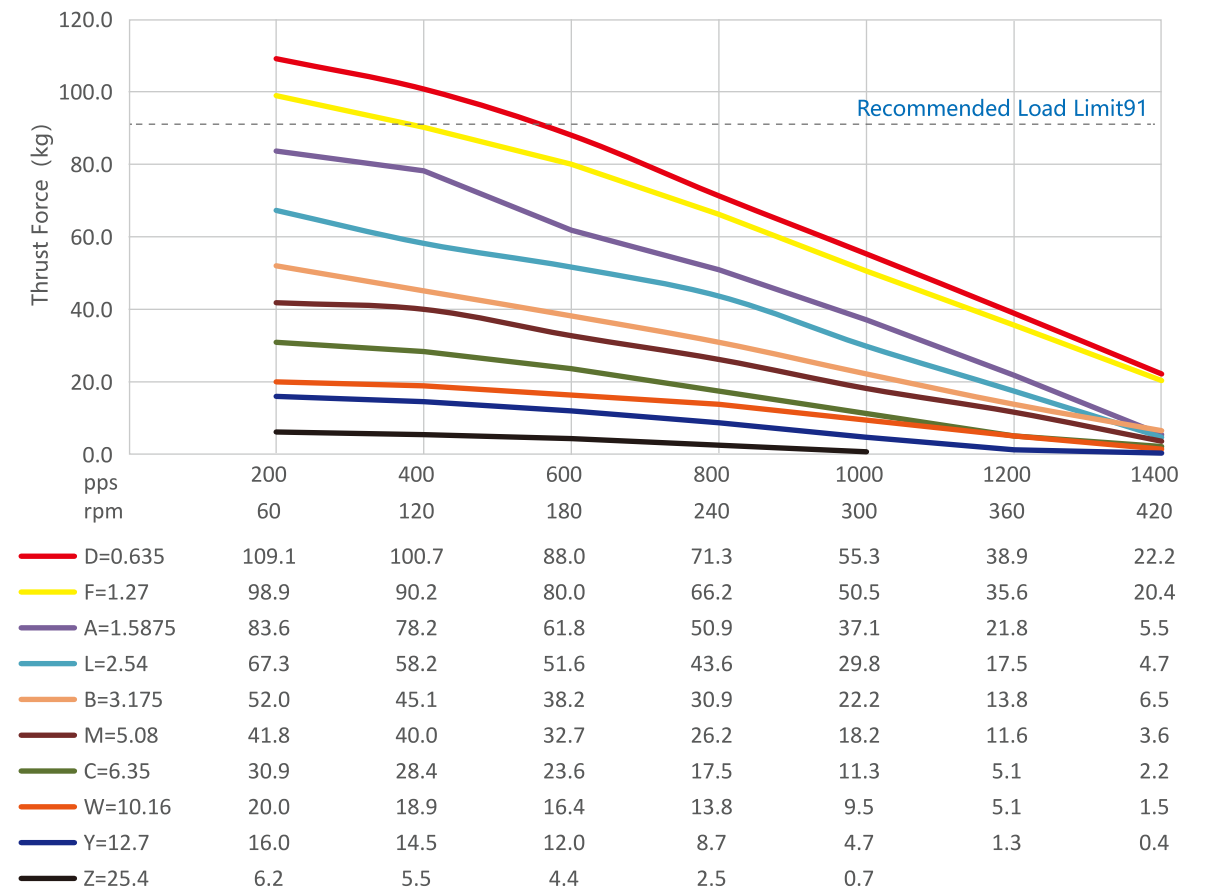

57mm(Size23) Linear Actuator , Double Stack

The 57mm(size 23) series Linear Actuator are available in three designs, captive, non-captive and external, with leads from 0.635mm to 25.4mm. Maximum thrust force is up to 90kg.

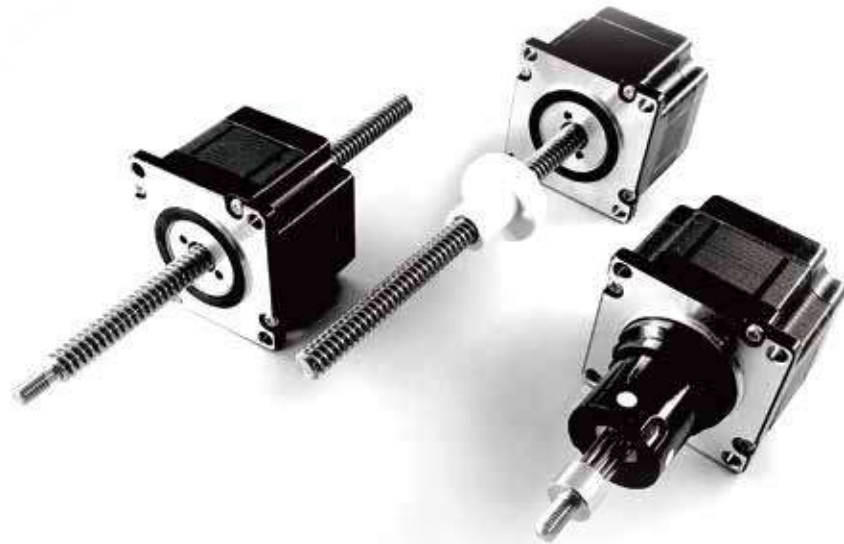

Electrical Parameter

Size 23: 57mm (2.3") Hybrid Linear Motor (1.8°Step Angle)			
Part No.	captive	57C2*	
	non-captive	57N2*	
	external	57E2*	
Wiring	Bipolar		
Wiring Voltage	3.25VDC	5VDC	12VDC
Current/Phase	3.3A	2.2A	0.9A
Resistance/Phase	0.98Ω	2.31Ω	13.33Ω
Inductance/Phase	3.2mH	7.6mH	35mH
Power Consumption/Total	25W		
Rotor Inertia	332gcm ²		
Temperature Rise	135°F (75°C)		
Insulation Class	Class B (Class F optional)		
Weight	958g		
Insulation Resistance	20MΩ		

Linear Travel/Strp (mm)	Lead (mm)	Lead Code
0.003175	0.635	D
0.00635	1.27	F
0.0079375	1.5875	A
0.0127	2.54	L
0.015875	3.175	B
0.254	5.08	M
0.3175	6.35	C
0.0508	10.16	W
0.0635	12.7	Y
0.127	25.4	Z

Outline

Captive

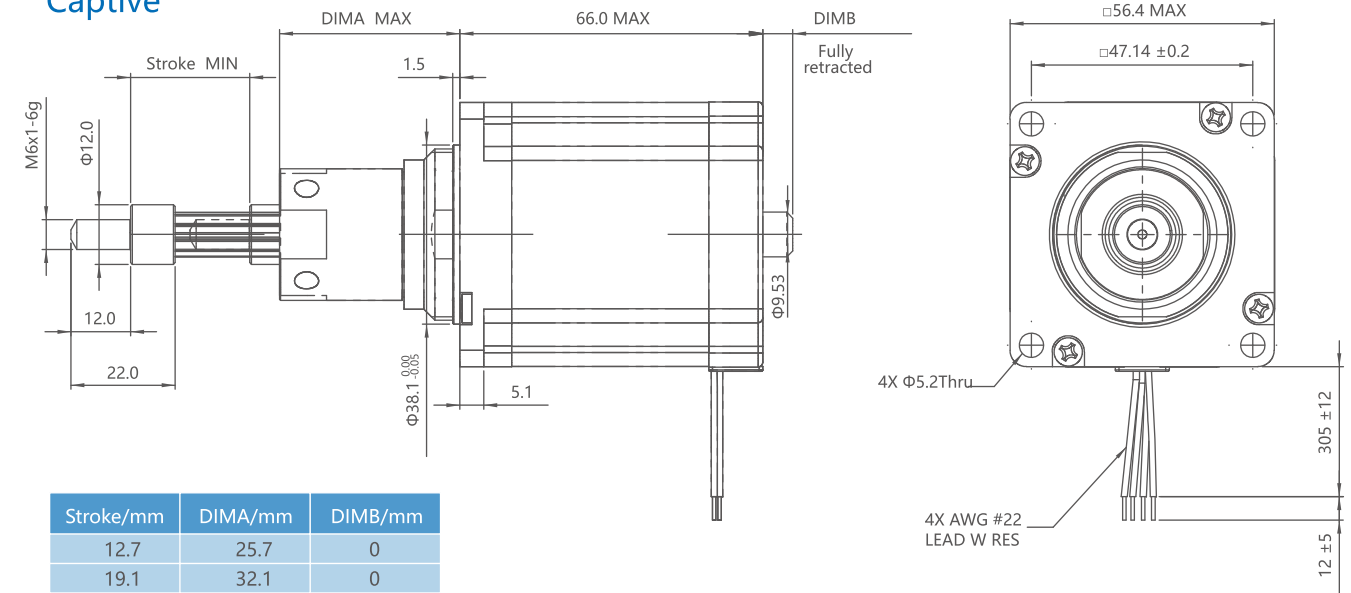

Stroke/mm	DIMA/mm	DIMB/mm
12.7	25.7	0
19.1	32.1	0
25.4	38.4	0
31.8	44.8	6.6
38.1	51.1	12.9
50.8	63.8	25.6
63.5	76.5	38.3

Non-captive

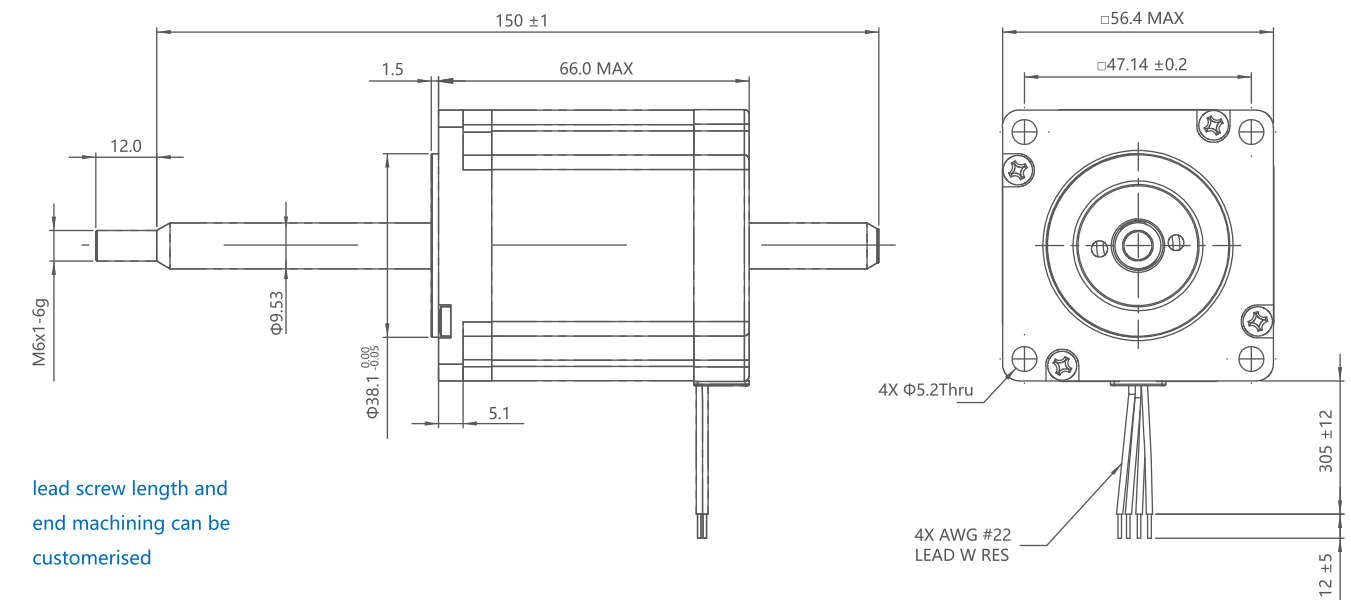

lead screw length and end machining can be customised

External

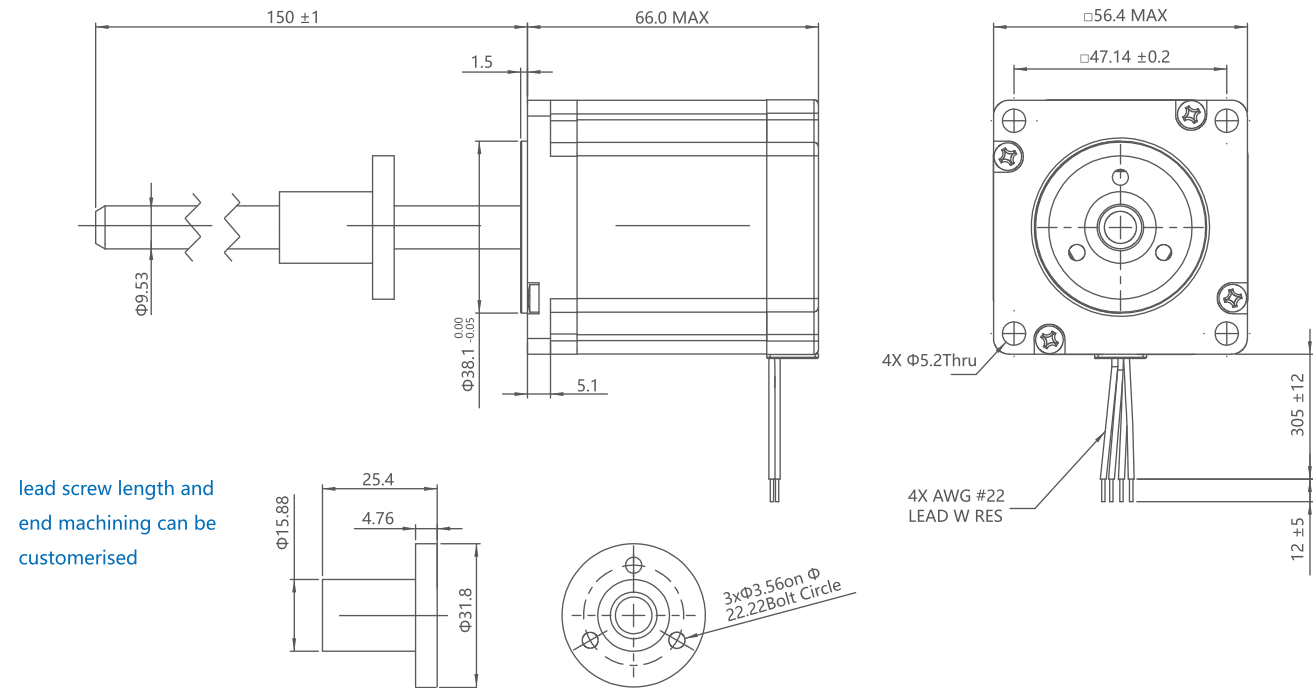

lead screw length and end machining can be customised

Force vs Pulse Curve

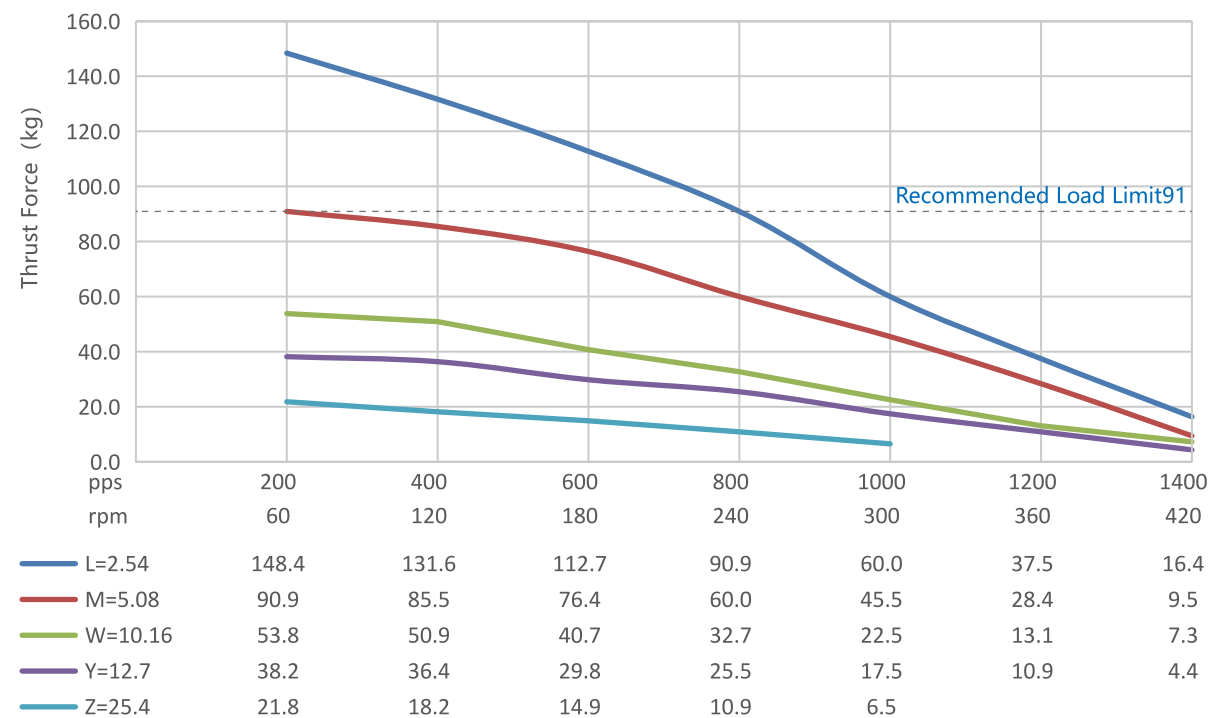

86mm(Size34) Linear Actuator

The 86mm(size 34) series Linear Actuator are available in three designs, captive, non-captive and external, with leads from 2.54mm to 25.4mm. Maximum thrust force is up to 220kg.

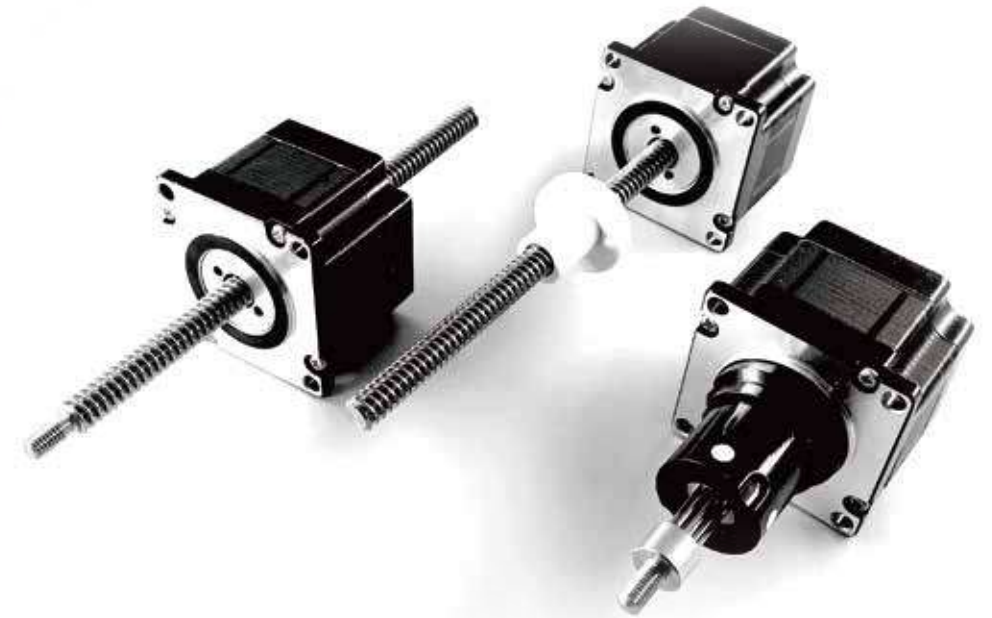

Electrical Parameter

Size 34: 86mm (3.4") Hybrid Linear Motor (1.8°Step Angle)			
Part No.	captive	86C1*	
	non-captive	86N1*	
	external	86E1*	
Wiring		Bipolar	
Wiring Voltage		2.85VDC	5VDC 12VDC
Current/Phase		5.47A	3.12A 1.3A
Resistance/Phase		0.52Ω	1.6Ω 9.23Ω
Inductance/Phase		2.86mH	8.8mH 51mH
Power Consumption/Total		31.2W	
Rotor Inertia		1760gcm ²	
Temperature Rise		135°F (75°C)	
Insulation Class		Class B (Class F optional)	
Weight		2.3Kg	
Insulation Resistance		20MΩ	

Linear Travel/Strp (mm)	Lead (mm)	Lead Code
0.0127	2.54	L
0.015875	3.175	B
0.254	5.08	M
0.3175	6.35	C
0.0635	12.7	Y
0.127	25.4	Z

Outline

Captive

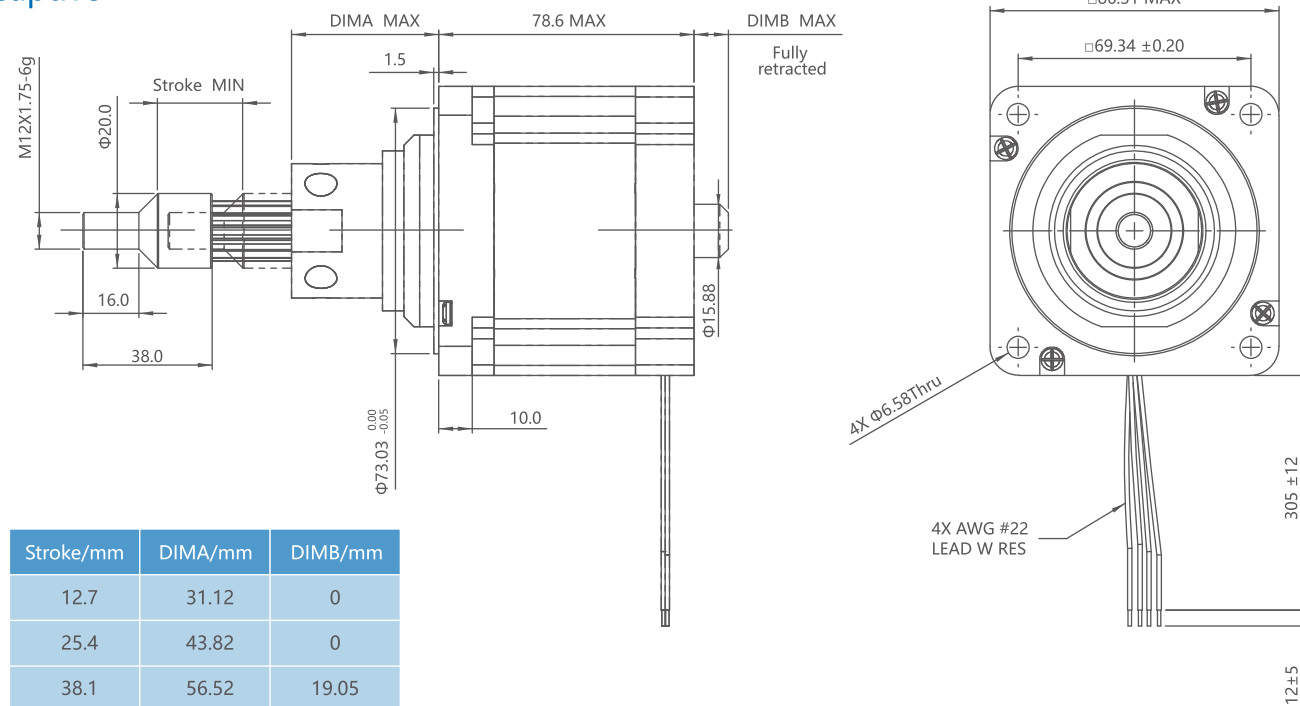

Stroke/mm	DIMA/mm	DIMB/mm
12.7	31.12	0
25.4	43.82	0
38.1	56.52	19.05
50.8	69.22	31.75
63.5	81.92	44.45

Non-captive

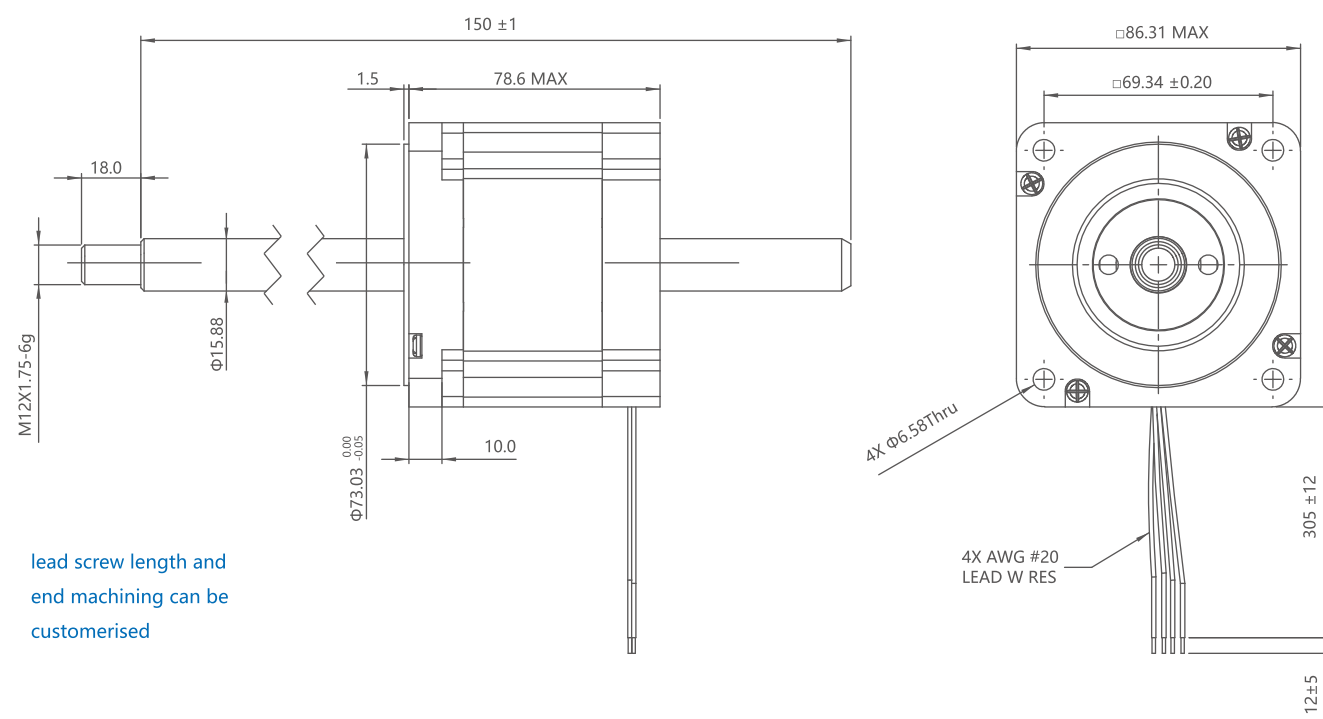

lead screw length and end machining can be customised

External

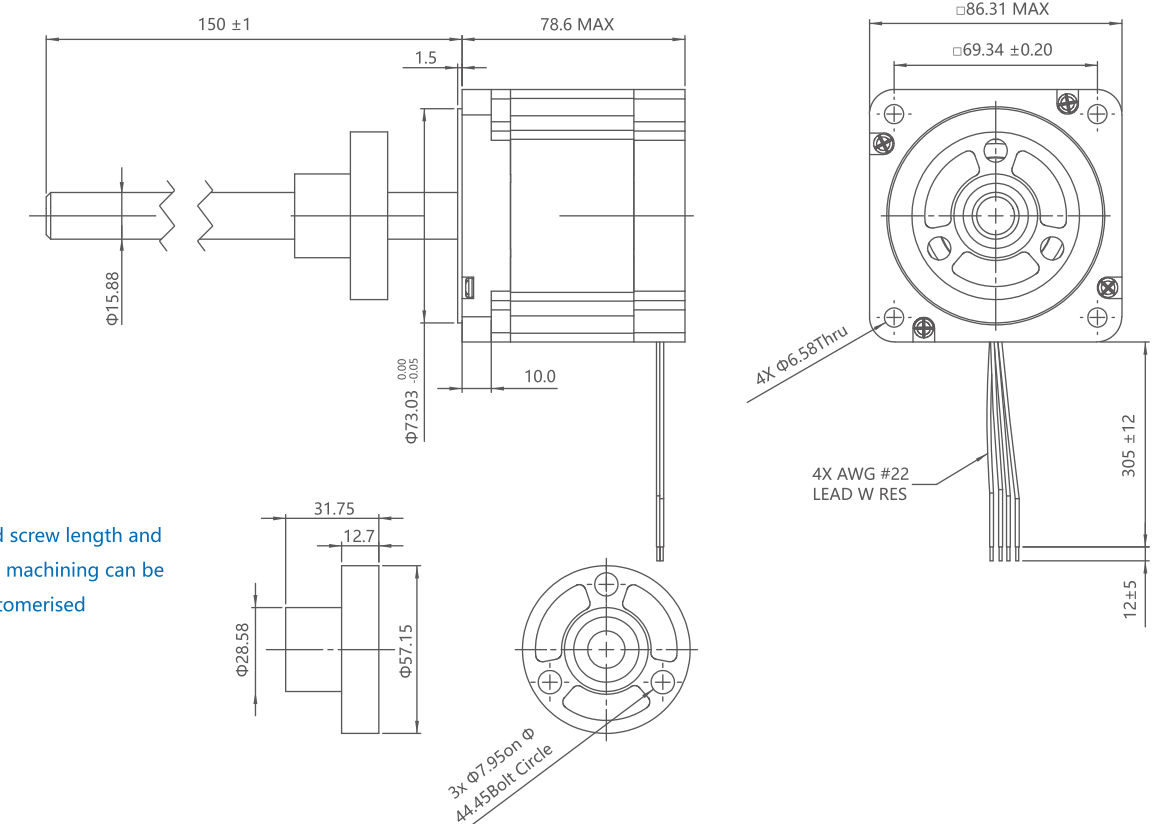

lead screw length and end machining can be customised

Force vs Pulse Curve

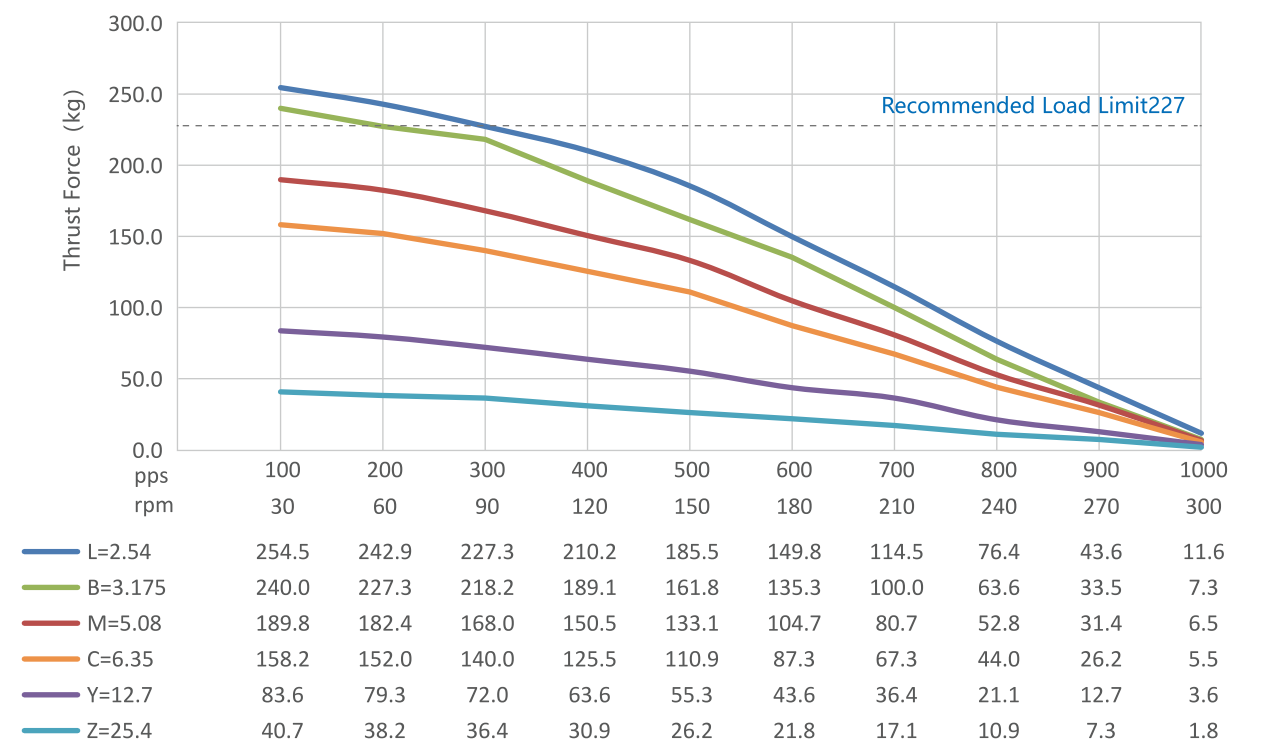

Ball Screw Actuator Series

14mm(Size6) Series Ball Screw Actuator

Electrical Parameter

Size6: 14mmBall screw actuator (1.8°Step Angle)		
Part No.	External	14E1*
Wiring		Bipolar
Wiring Voltage		6.6VDC
Current/Phase		0.3A
Resistance/Phase		22 Ω ±10%
Inductance/Phase		4.2 mH
Power Consumption/Total		1.94W
Temperature Rise		135°F (75°C)
Insulation Class		Class B (Class F optional)
Insulation Resistance		50MΩ



Outline

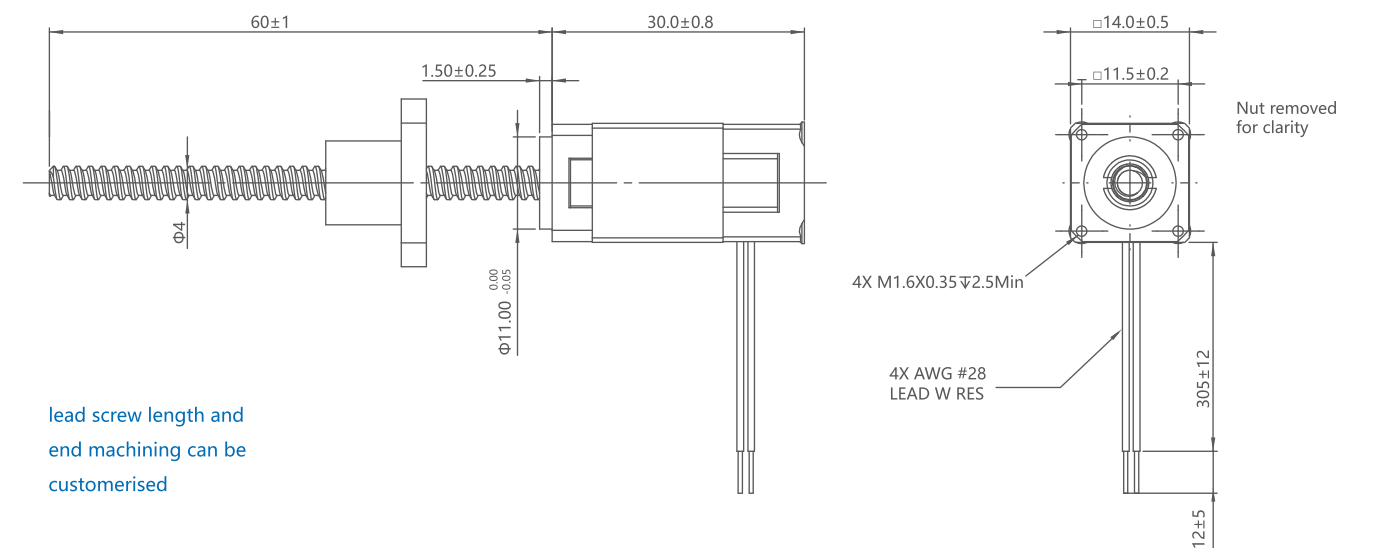

lead screw length and end machining can be customised

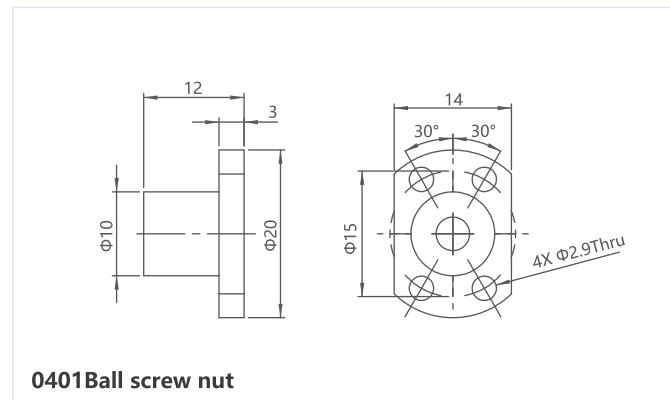

Force vs Pulse Curve

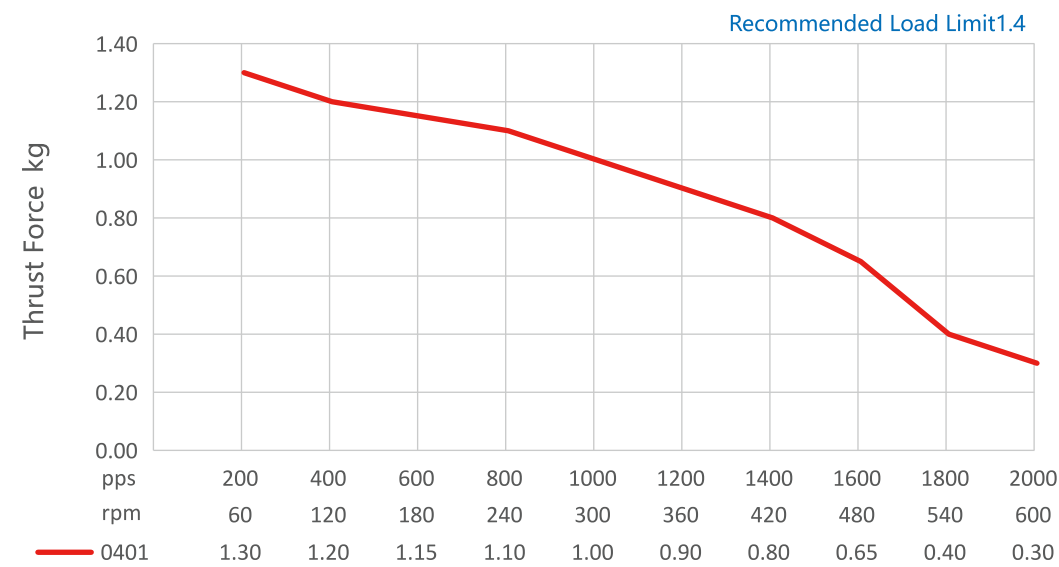

20mm(Size8) Series Ball Screw Actuator , Single Stack

Electrical Parameter

Size 8: 20mmBall screw actuator (1.8°Step Angle)			
Part No.	External	20E1*	
Wiring	Bipolar		
Wiring Voltage	2.5VDC	5VDC	7.5VDC
Current/Phase	0.5A	0.24A	0.16A
Resistance/Phase	5.1Ω	20.4Ω	45.9Ω
Inductance/Phase	1.6mH	5.0mH	11.7mH
Power Consumption/Total	2.45W		
Temperature Rise	135°F (75°C)		
Insulation Resistance	20MΩ		
Insulation Class	Class B (Class F optional)		



Outline

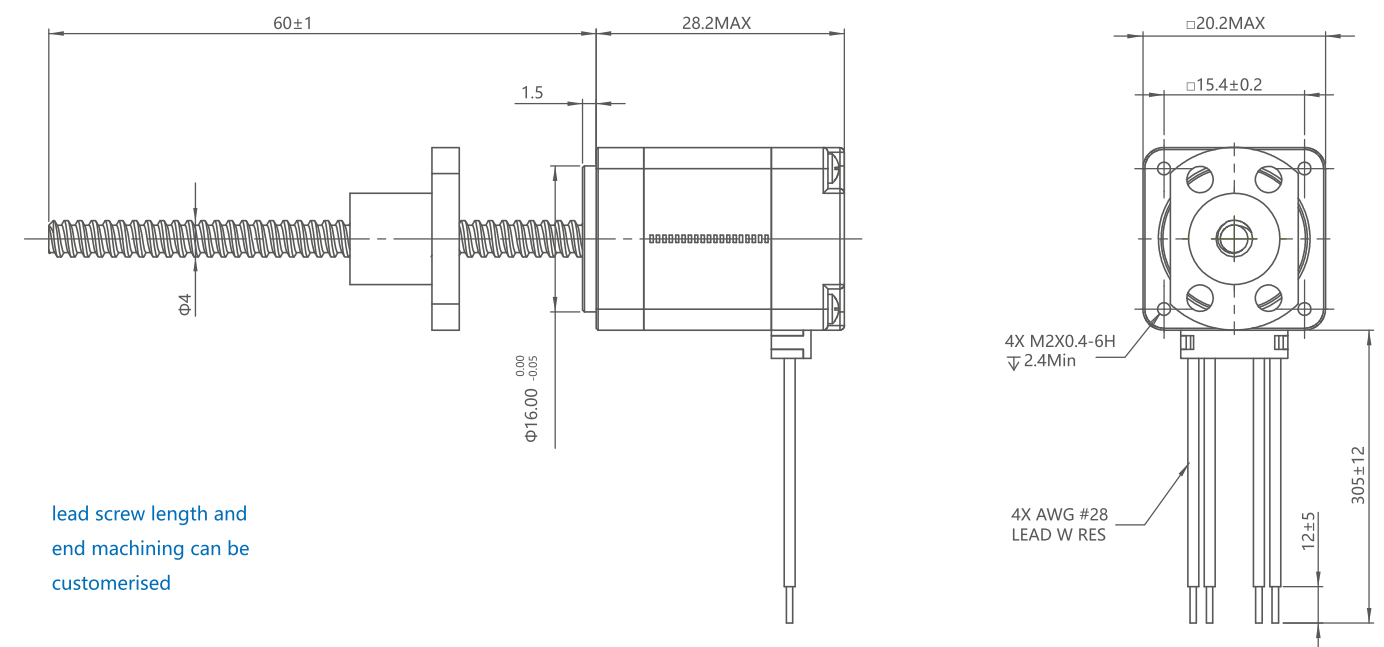

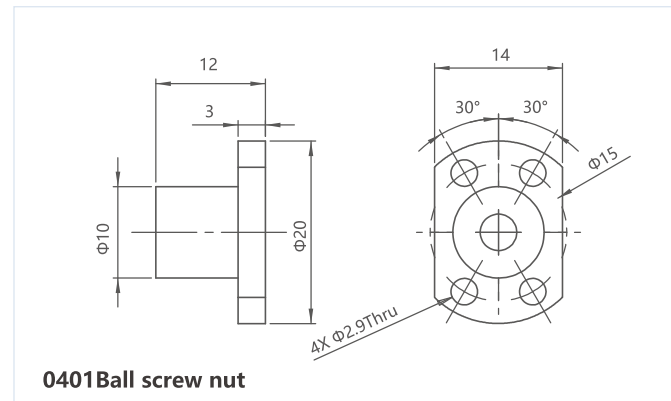

Force vs Pulse Curve

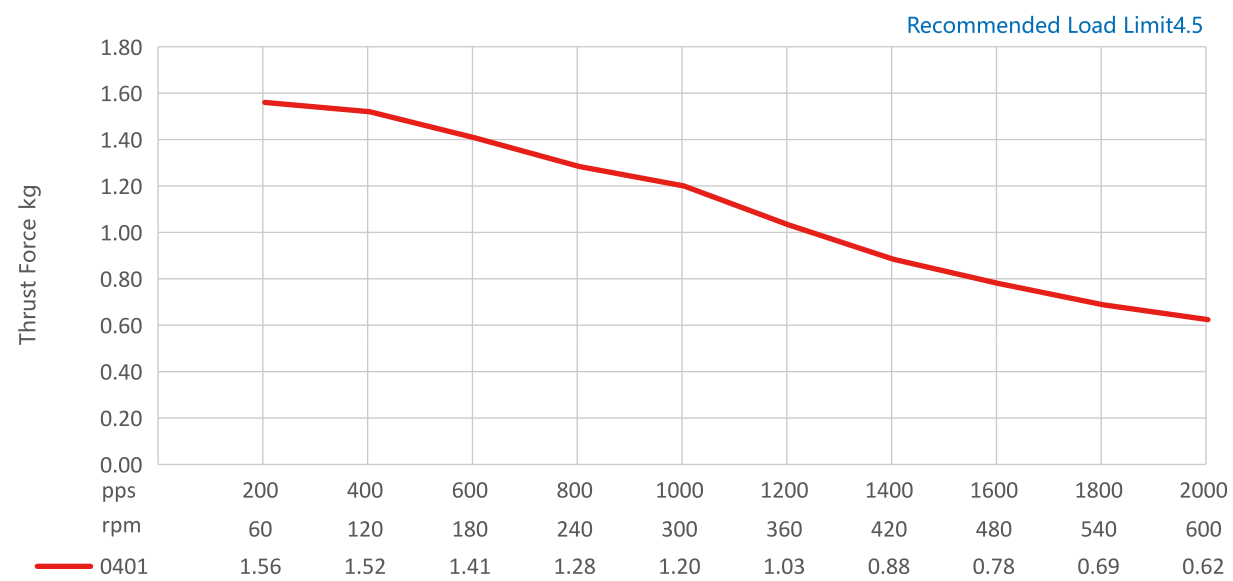

20mm(Size8) Series Ball Screw Actuator , Double Stack

Electrical Parameter

Size 8 : 20mmBall screw actuator (1.8°Step Angle)			
Part No.	External	20E2*	
Wiring		Bipolar	
Wiring Voltage	2.5VDC	5VDC	7.5VDC
Current/Phase	1.32A	0.65A	0.43A
Resistance/Phase	1.9Ω	7.7Ω	17.3Ω
Inductance/Phase	0.75mH	3mH	16mH
Power Consumption/Total	6.5W		
Temperature Rise	135°F (75°C)		
Insulation Class	Class B (Class F optional)		
Insulation Resistance	20MΩ		



Outline

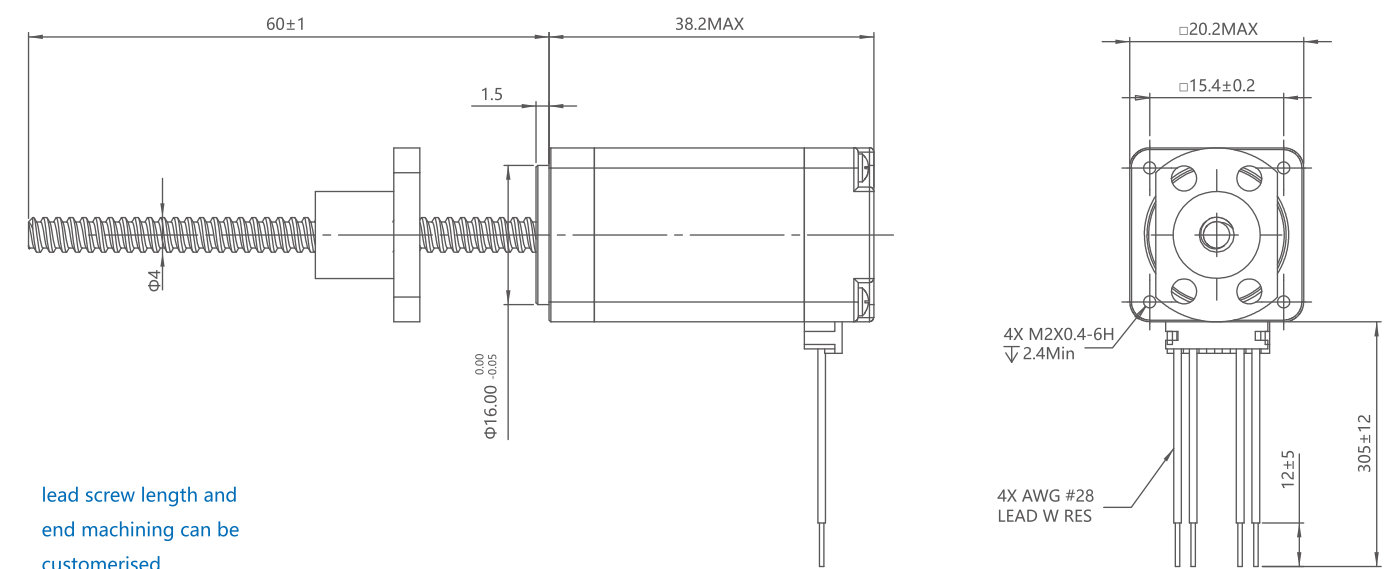

lead screw length and end machining can be customised

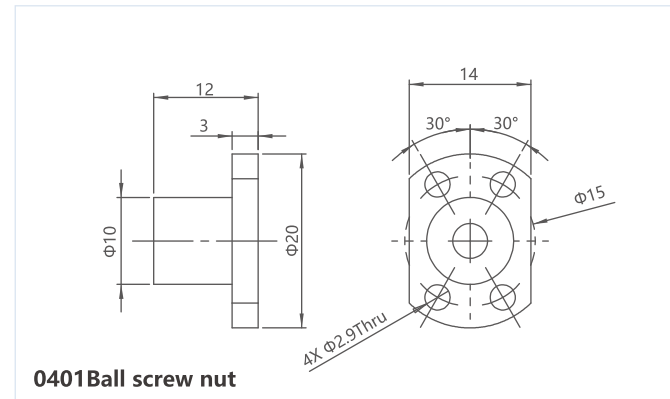

Force vs Pulse Curve

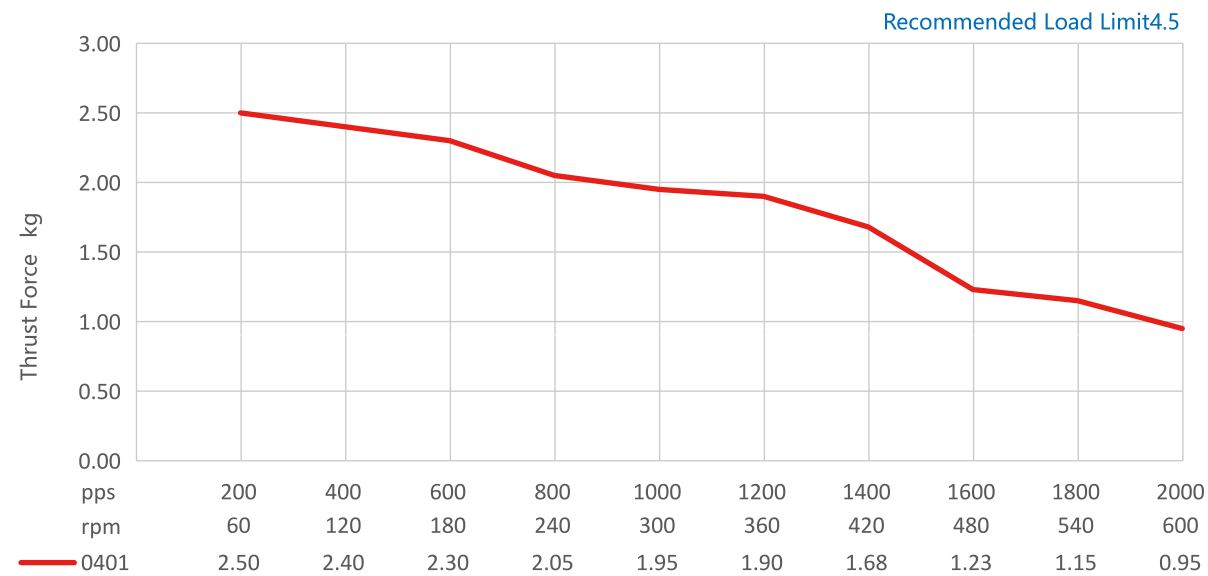

28mm(Size11) Series Ball Screw Actuator , Single Stack

Electrical Parameter

Size 11: 28mm (1.1") Ball screw actuator (1.8°Step Angle)			
Part No.	External	28E1*	
Wiring	Bipolar		
Wiring Voltage	2.1VDC	5VDC	12VDC
Current/Phase	1.0A	0.42A	0.18A
Resistance/Phase	2.1Ω	11.9Ω	66Ω
Inductance/Phase	1.5mH	8.5mH	50.3mH
Power Consumption/Total	4.2W		
Temperature Rise	135°F (75°C)		
Insulation Class	Class B (Class F optional)		
Insulation Resistance	20MΩ		



Outline

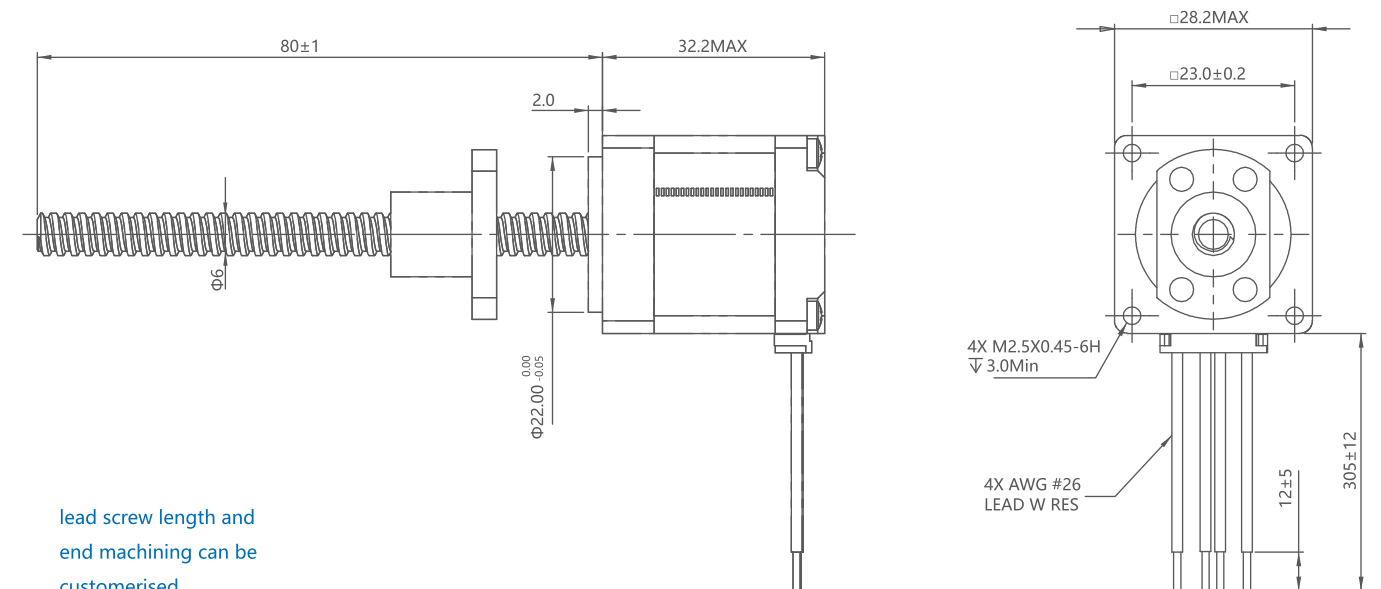

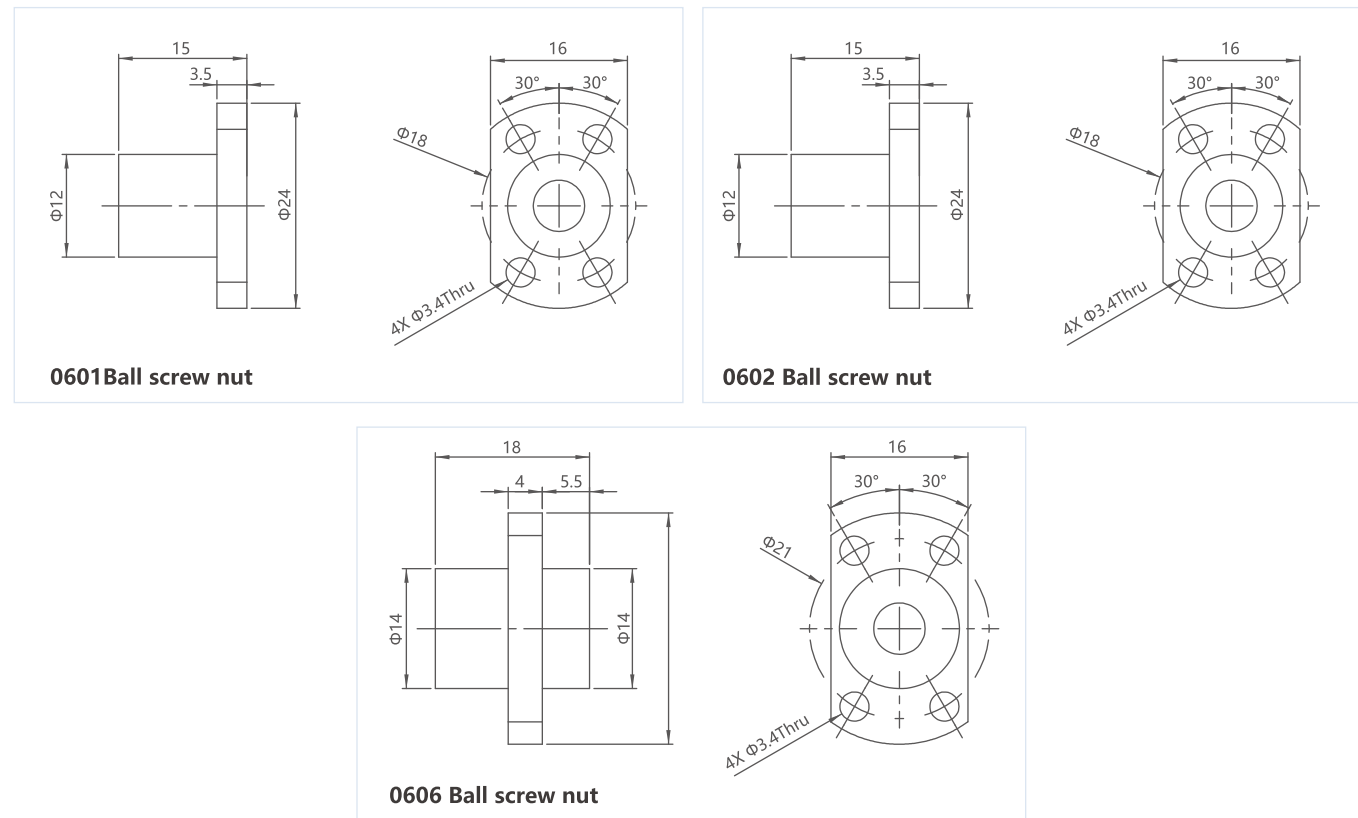

Force vs Pulse Curve

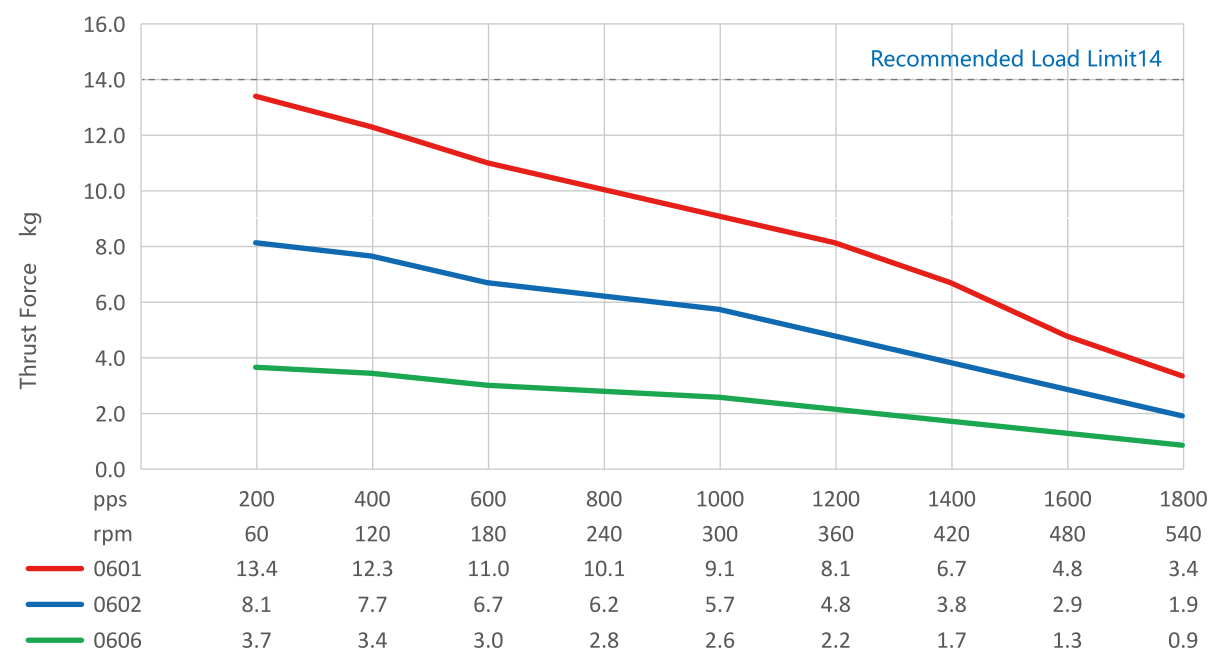

28mm(Size11) Series Ball Screw Actuator , Double Stack

Electrical Parameter

Size 11: 28mm (1.1") Ball screw actuator (1.8°Step Angle)			
Part No.	External	28E2*	
Wiring	Bipolar		
Wiring Voltage	2.1VDC	5VDC	12VDC
Current/Phase	1.9A	0.75A	0.35A
Resistance/Phase	1.2Ω	6.7Ω	34.8Ω
Inductance/Phase	1.0mH	5.8mH	35.6mH
Power Consumption/Total	7.5W		
Temperature Rise	135°F (75°C)		
Insulation Class	Class B (Class F optional)		
Insulation Resistance	20MΩ		



Outline

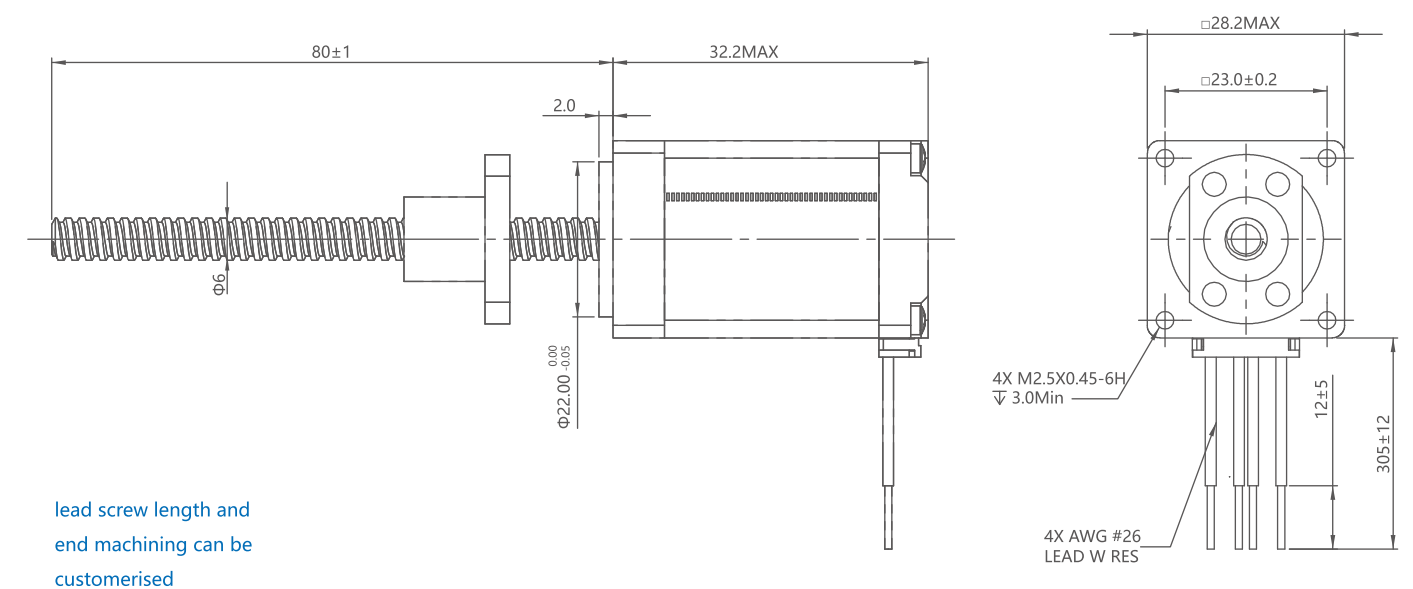

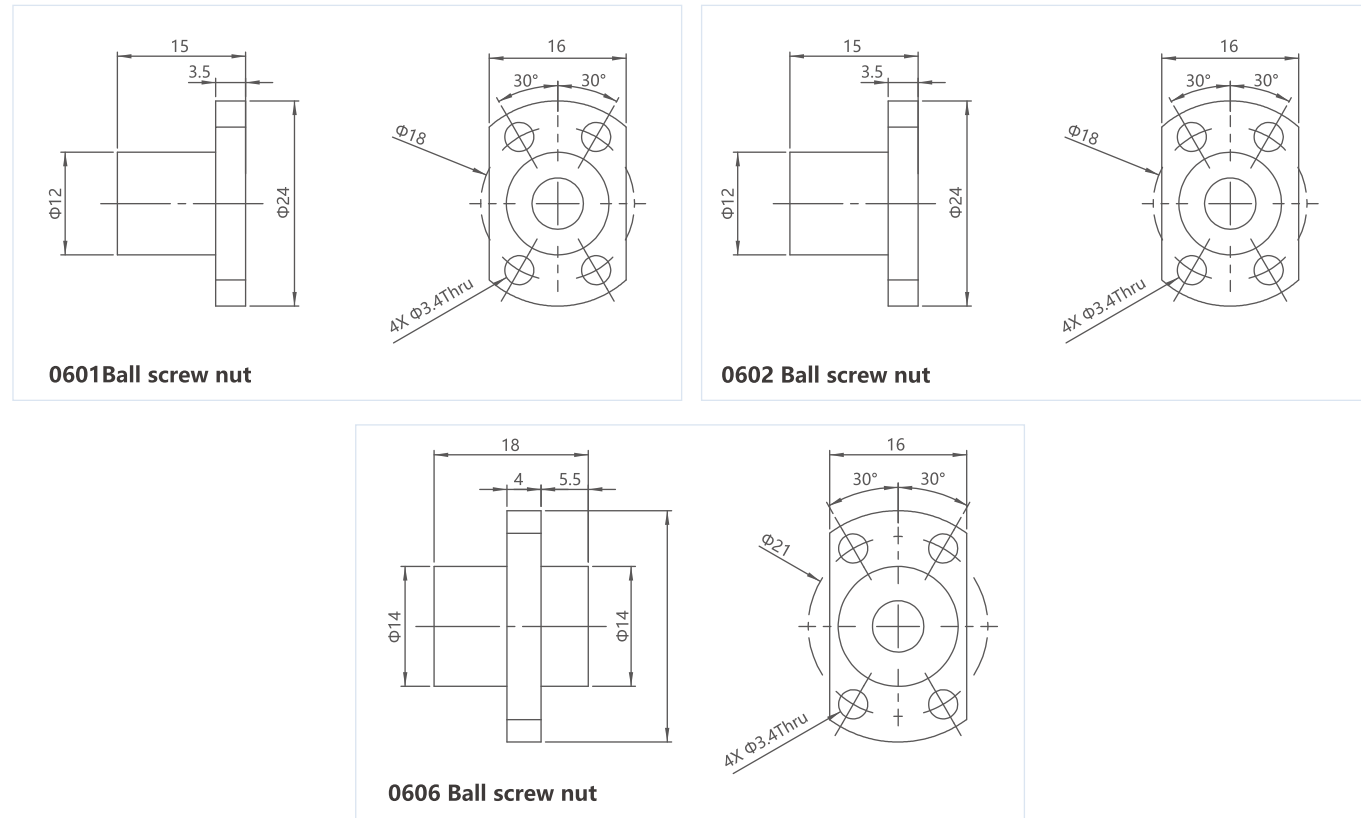

35mm(Size14) Series Ball Screw Actuator , Single Stack

Electrical Parameter

Size 14: 35mm (1.4") Ball screw actuator (1.8°Step Angle)			
Part No.	External	35E1*	
Wiring	Bipolar		
Wiring Voltage	2.33VDC	5VDC	12VDC
Current/Phase	1.25A	0.57A	0.24A
Resistance/Phase	1.86Ω	8.8Ω	50.5Ω
Inductance/Phase	3mH	14mH	66mH
Power Consumption/Total	5.7W		
Temperature Rise	135°F (75°C)		
Insulation Class	Class B (Class F optional)		
Insulation Resistance	20MΩ		



Force vs Pulse Curve

28mm double stack actuator thrust force curve

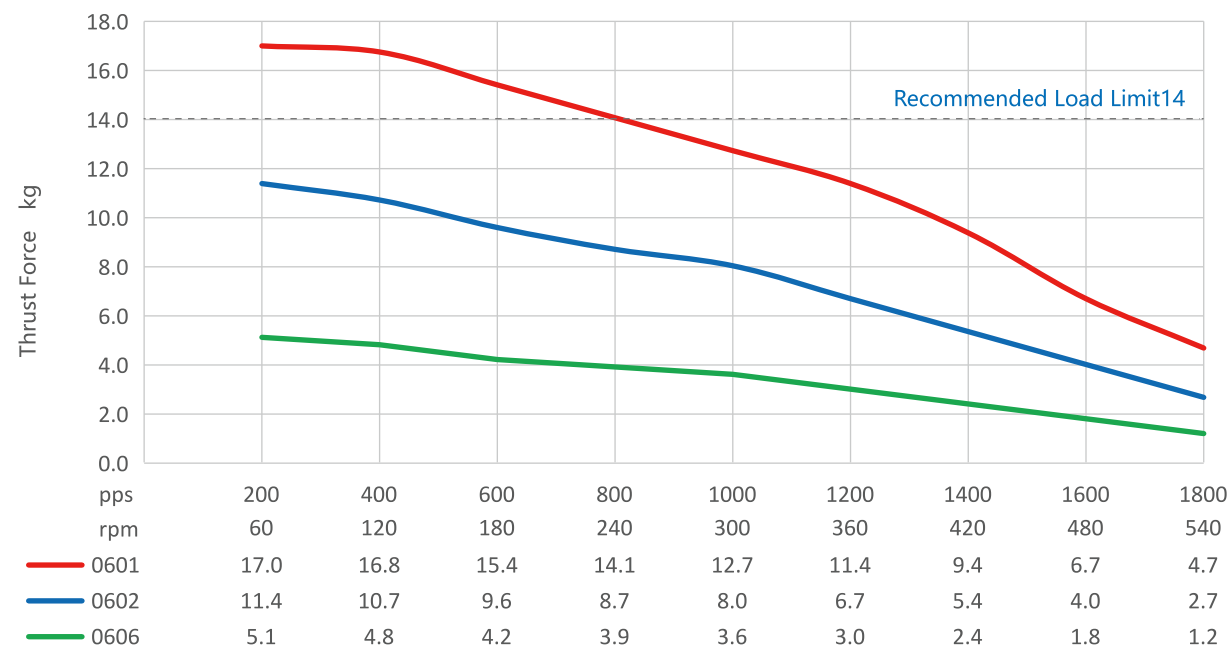

Outline

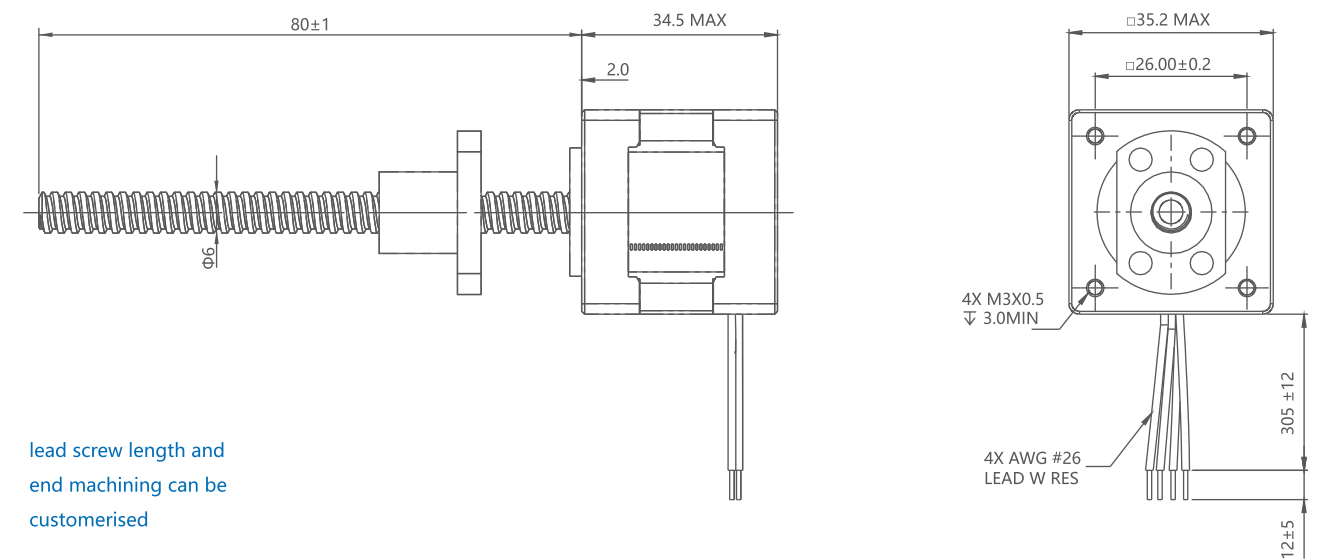

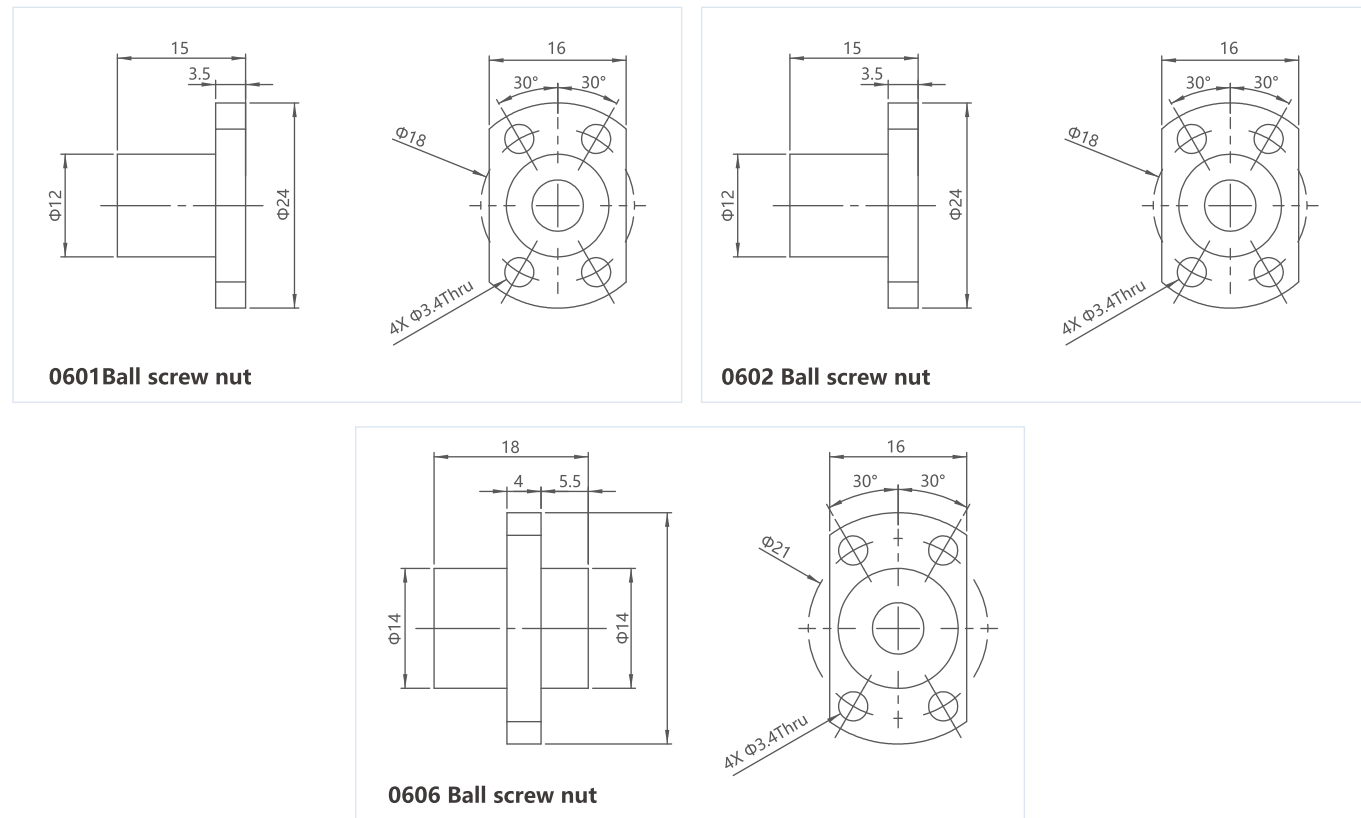

35mm(Size14) Series Ball Screw Actuator , Double Stack

Electrical Parameter

Size 14: 35mm (1.4") Ball screw actuator (1.8°Step Angle)			
Part No.	External	35E2*	
Wiring	Bipolar		
Wiring Voltage	2.33VDC	5VDC	12VDC
Current/Phase	2A	0.91A	0.38A
Resistance/Phase	1.2Ω	5.5Ω	31.6Ω
Inductance/Phase	1.95mH	7.63mH	65.1mH
Power Consumption/Total	9.1W		
Temperature Rise	135°F (75°C)		
Insulation Class	Class B (Class F optional)		
Insulation Resistance	20MΩ		



Outline

Force vs Pulse Curve

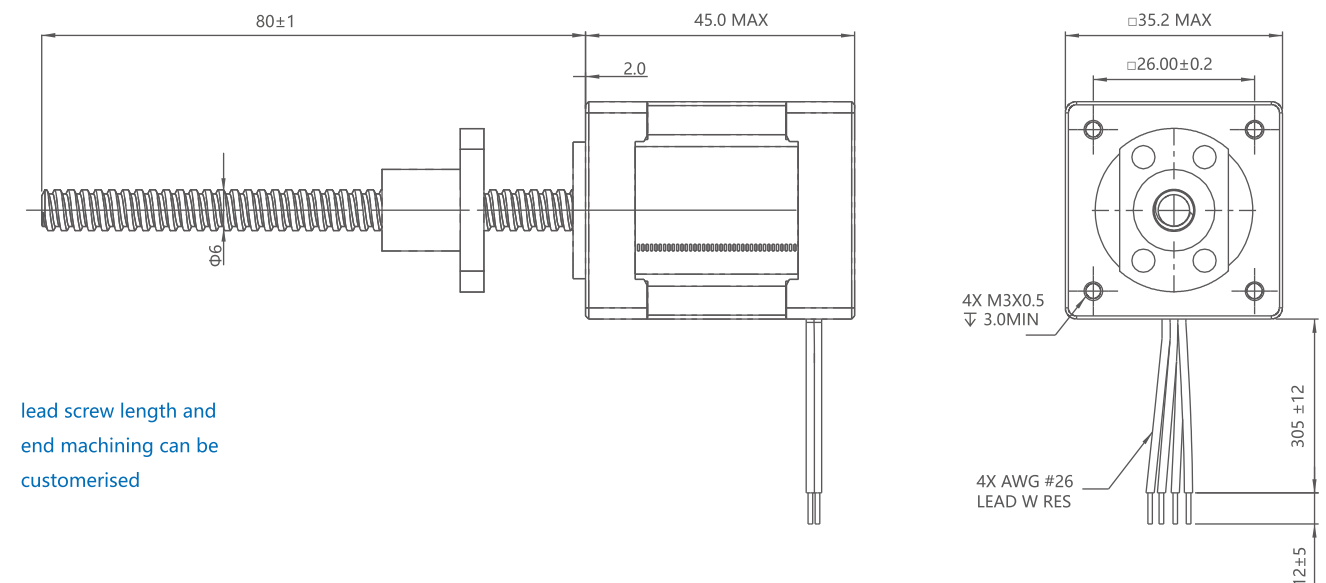
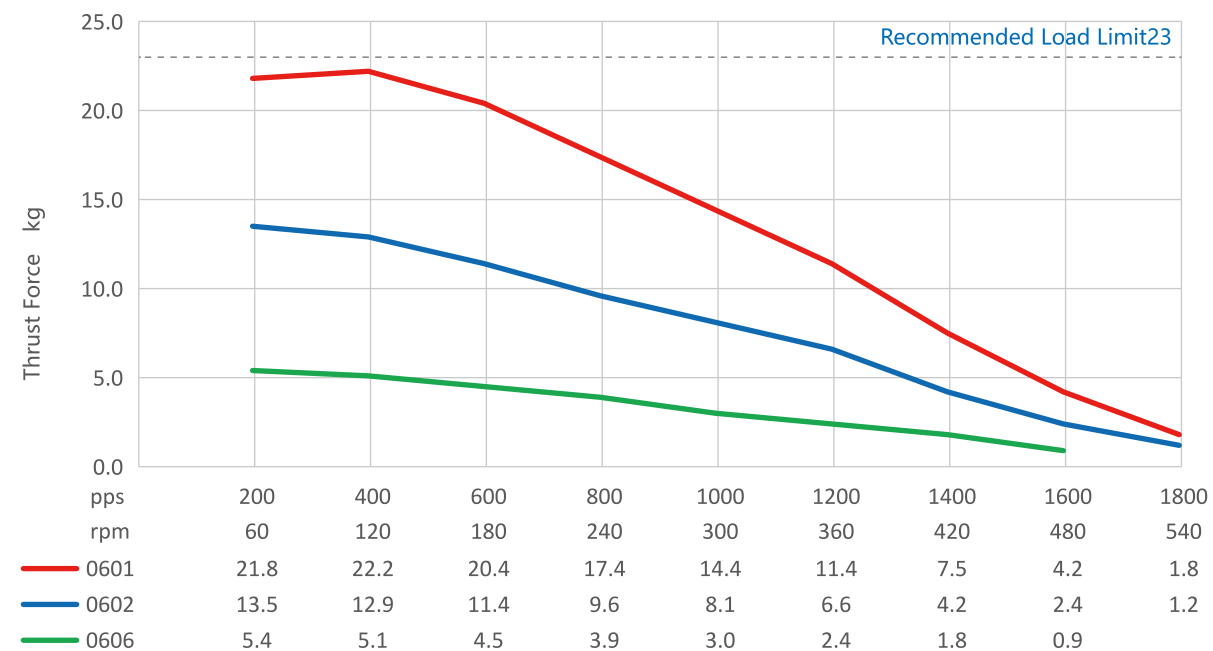

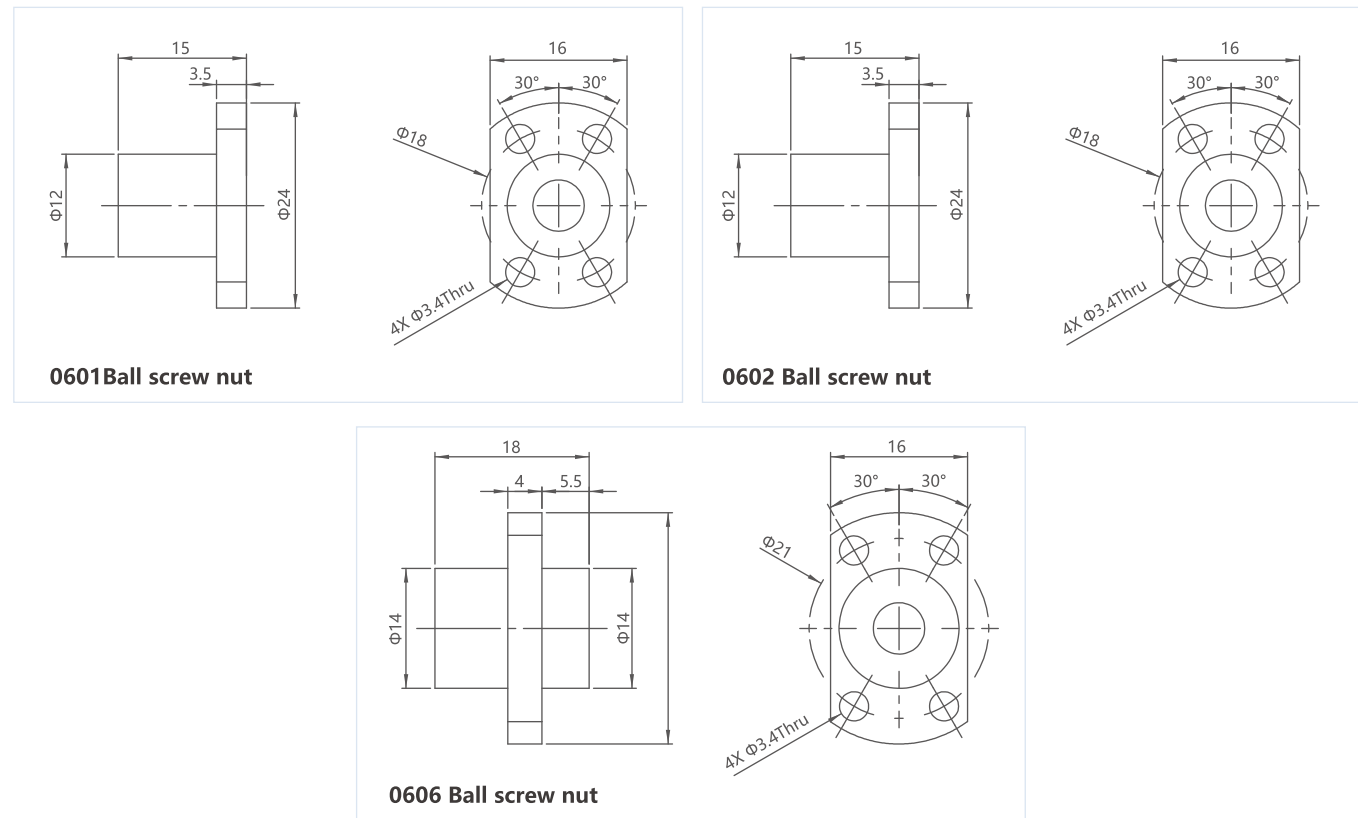

42mm(Size17) Series Ball Screw Actuator , Single Stack

Electrical Parameter

Size 17: 42mm (1.7") Ball screw actuator (1.8°Step Angle)			
Part No.	External	42E1*	
Wiring	Bipolar		
Wiring Voltage	2.33VDC	5VDC	12VDC
Current/Phase	1.5A	0.7A	0.29A
Resistance/Phase	1.56Ω	7.2Ω	41.5Ω
Inductance/Phase	1.9mH	9.5mH	54.0mH
Power Consumption/Total	10.4W		
Temperature Rise	135°F (75°C)		
Insulation Class	Class B (Class F optional)		
Insulation Resistance	20MΩ		



Outline

Force vs Pulse Curve

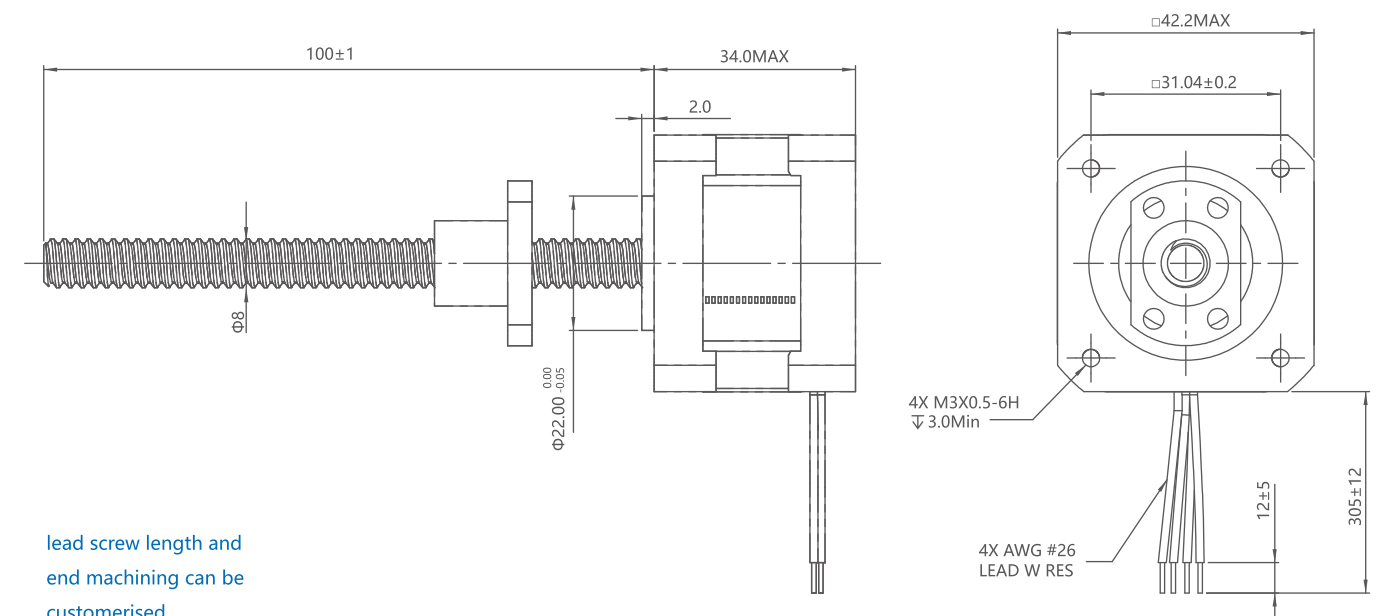
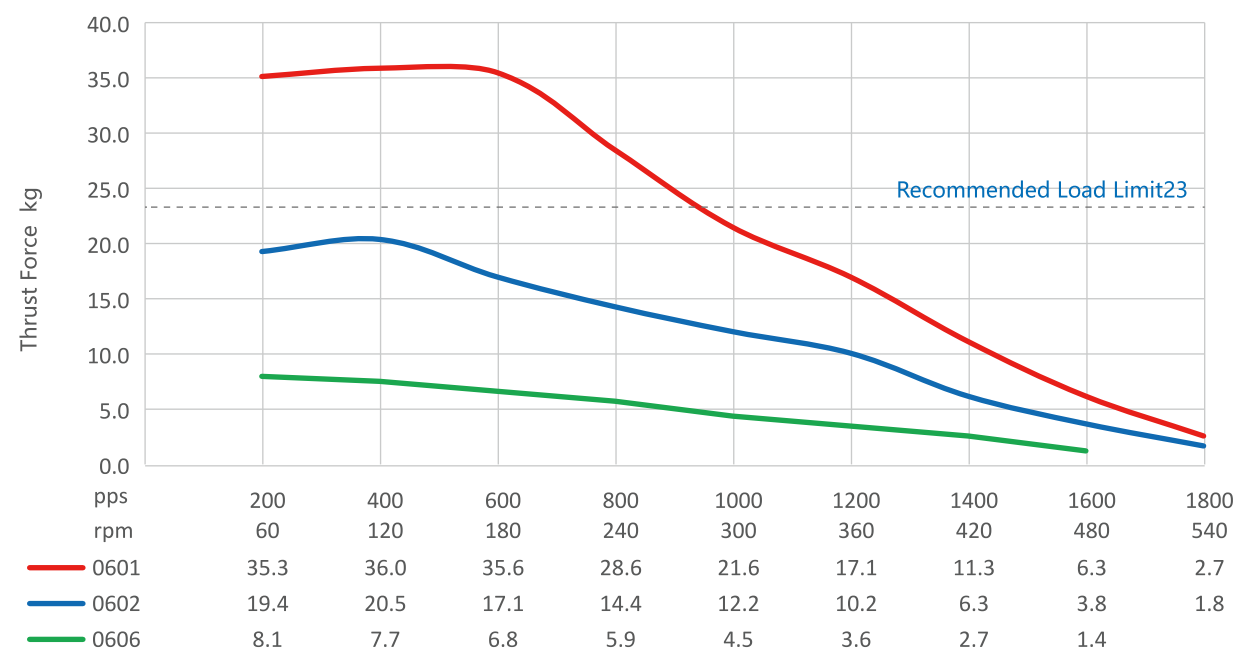

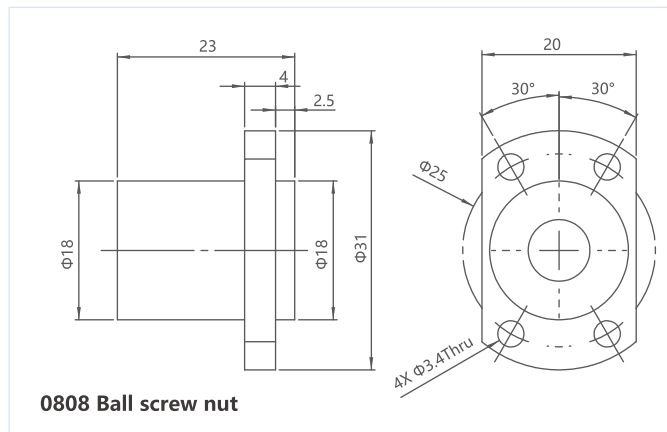
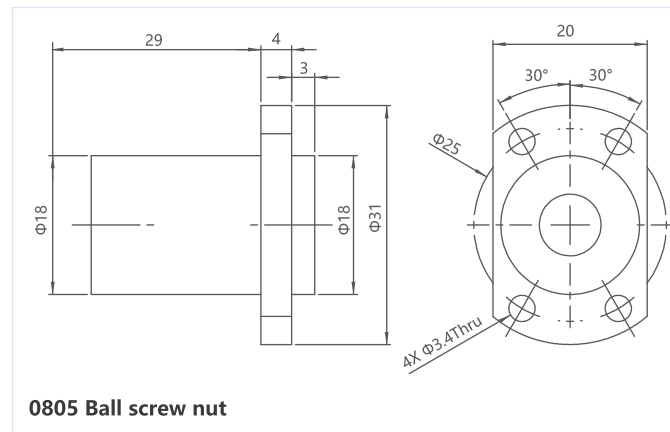
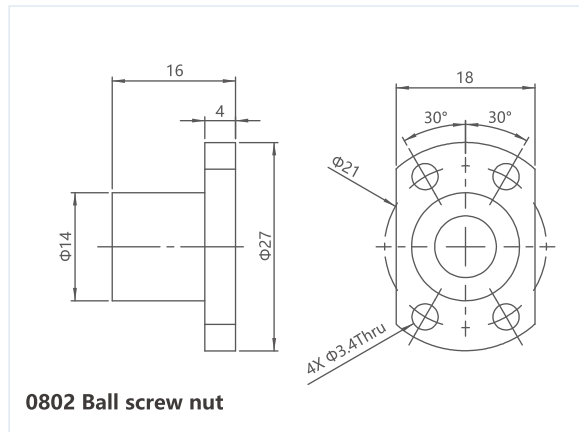
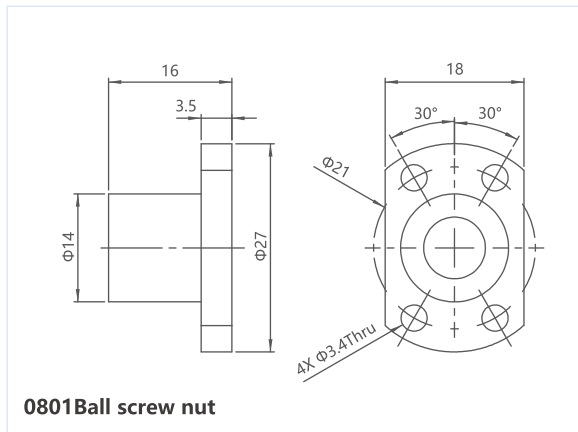

42mm(Size17) Series Ball Screw Actuator , Double Stack

Electrical Parameter

Size 17: 42mm (1.7") Ball screw actuator (1.8°Step Angle)			
Part No.	External	42E2*	
Wiring	Bipolar		
Wiring Voltage	2.33VDC	5VDC	12VDC
Current/Phase	2.6A	1.3A	0.55A
Resistance/Phase	0.85Ω	3.8Ω	21.9Ω
Inductance/Phase	1.1mH	7.8mH	45.1mH
Power Consumption/Total	10.4W		
Temperature Rise	135°F (75°C)		
Insulation Class	Class B (Class F optional)		
Insulation Resistance	20MΩ		



Force vs Pulse Curve

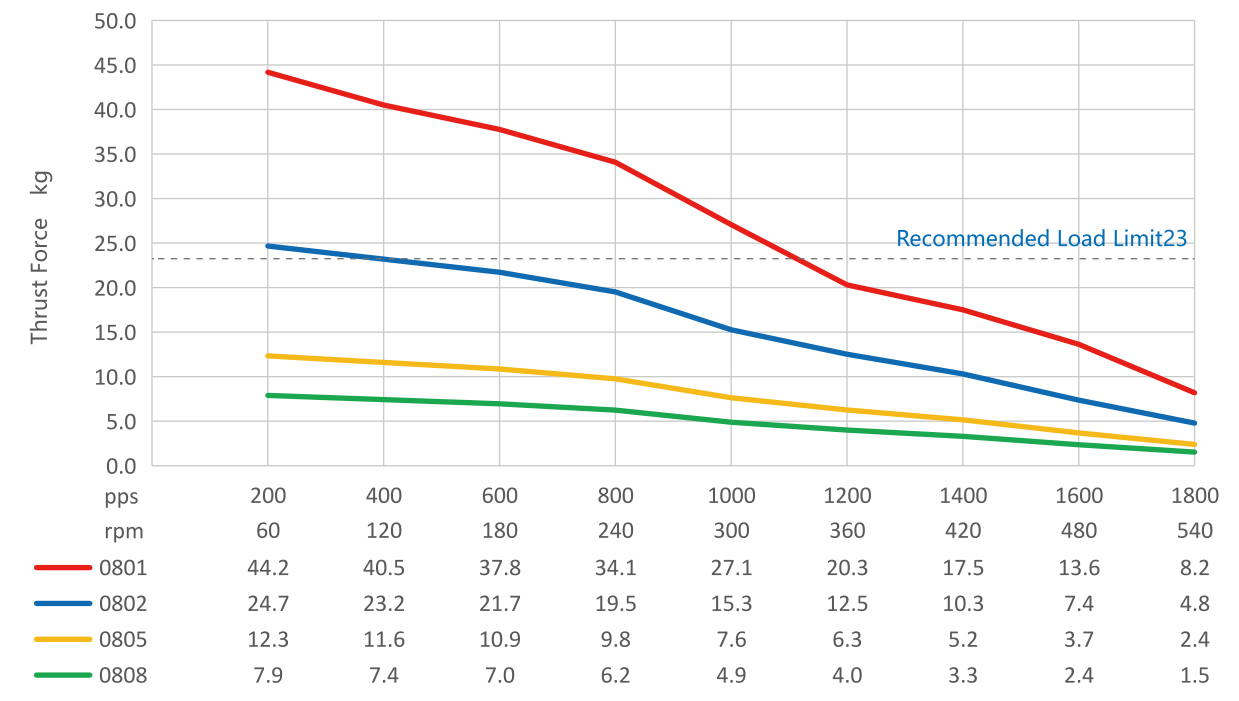

Outline

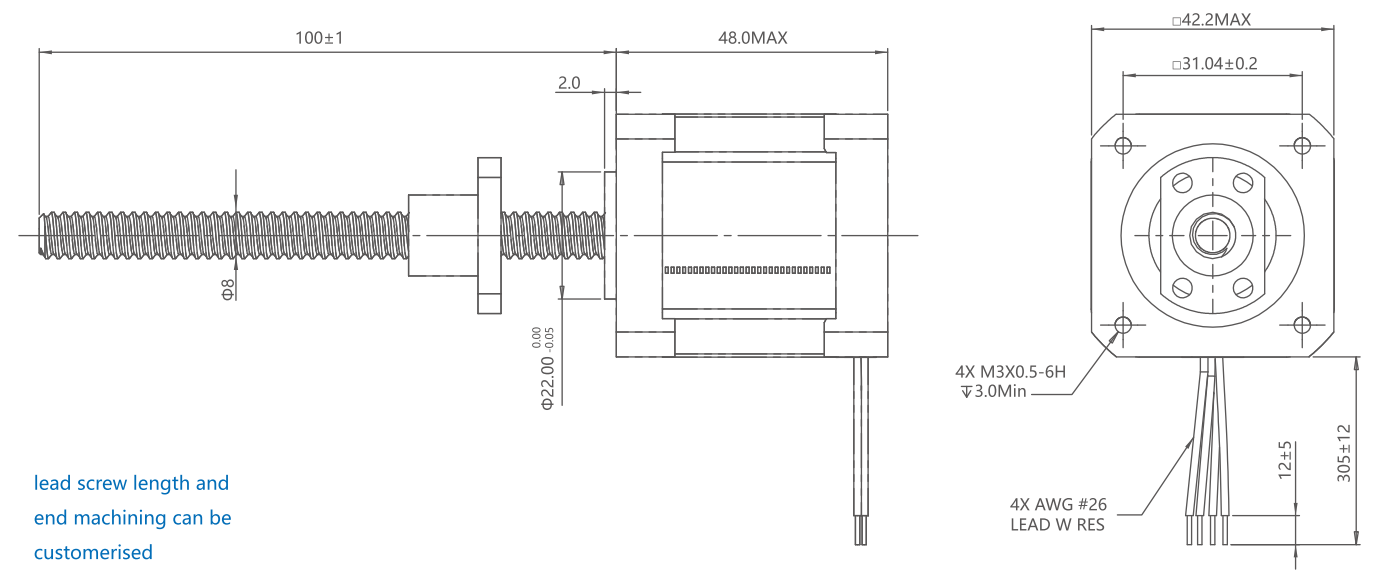

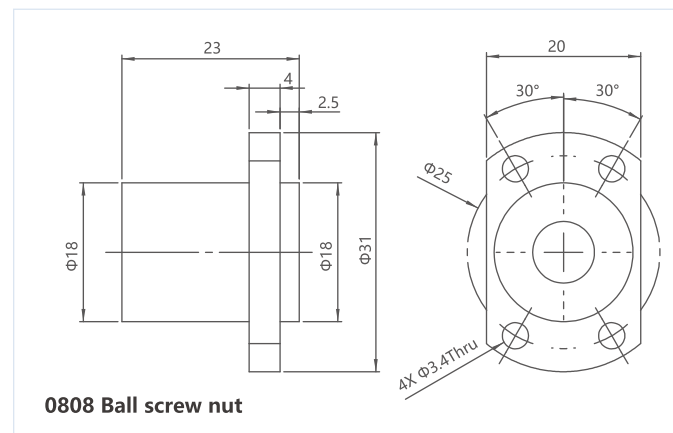
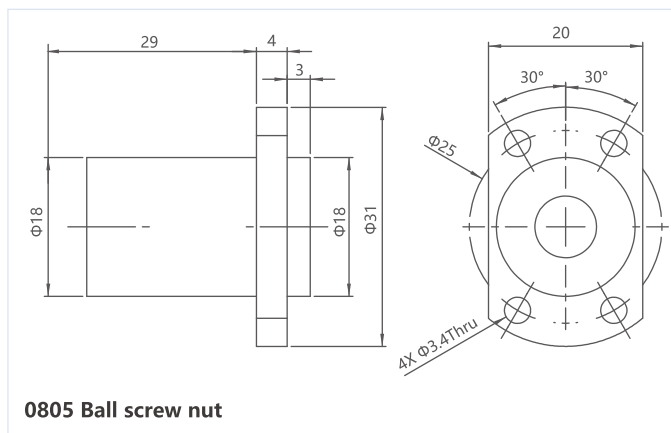
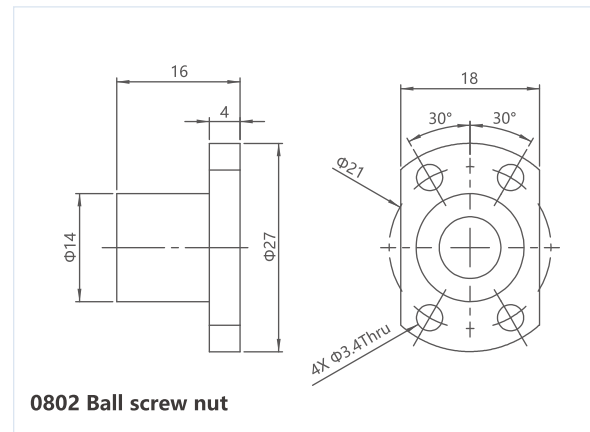
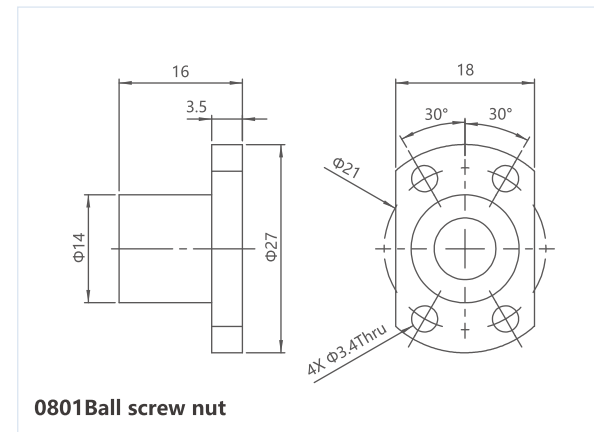

57mm(Size23) Series Ball Screw Actuator , Single Stack

Electrical Parameter

Size 23: 57mm (2.3") Ball screw actuator (1.8°Step Angle)			
Part No.	External	57E1*	
Wiring	Bipolar		
Wiring Voltage	3.25VDC	5VDC	12VDC
Current/Phase	2.0A	1.3A	0.55A
Resistance/Phase	1.6Ω	3.8Ω	22Ω
Inductance/Phase	3.5mH	15.5mH	58mH
Power Consumption/Total	13W		
Temperature Rise	135°F (75°C)		
Insulation Class	Class B (Class F optional)		
Insulation Resistance	20MΩ		



Outline

Force vs Pulse Curve

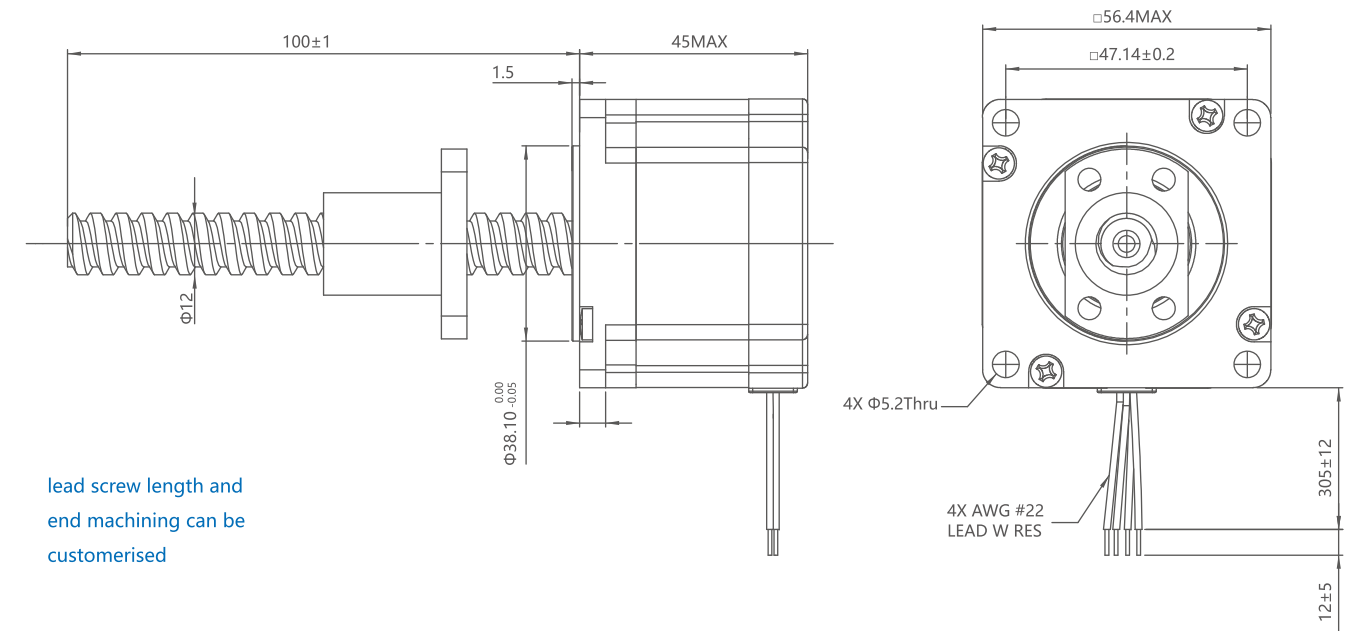
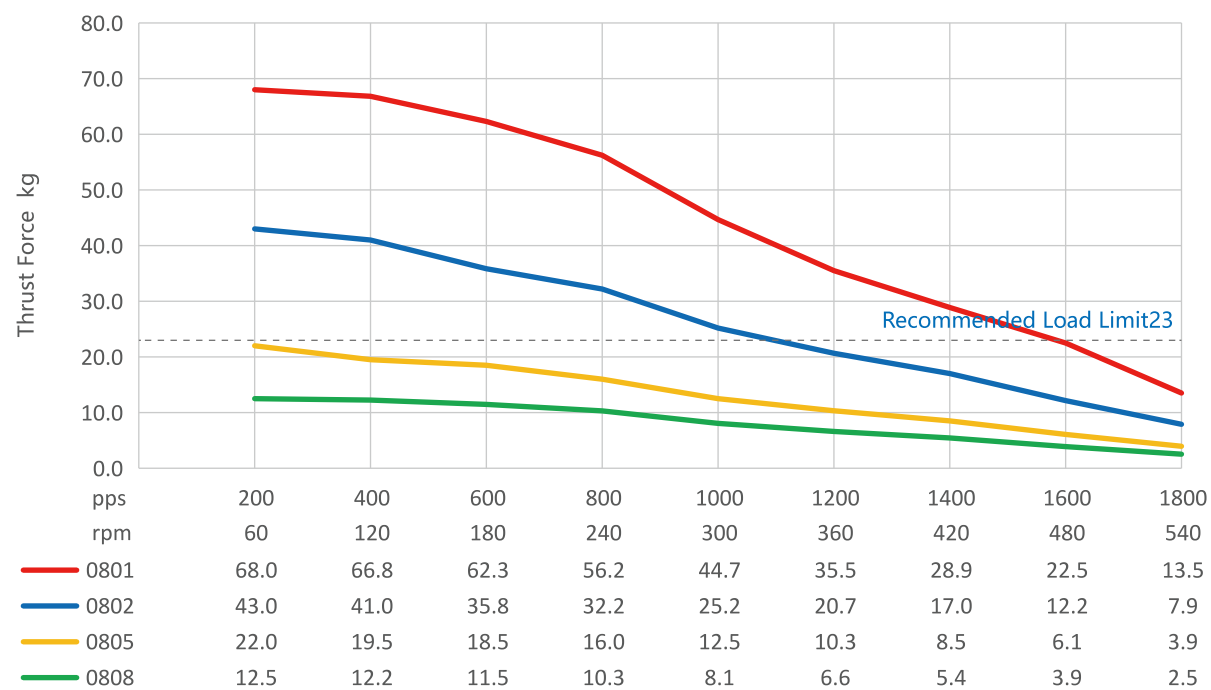

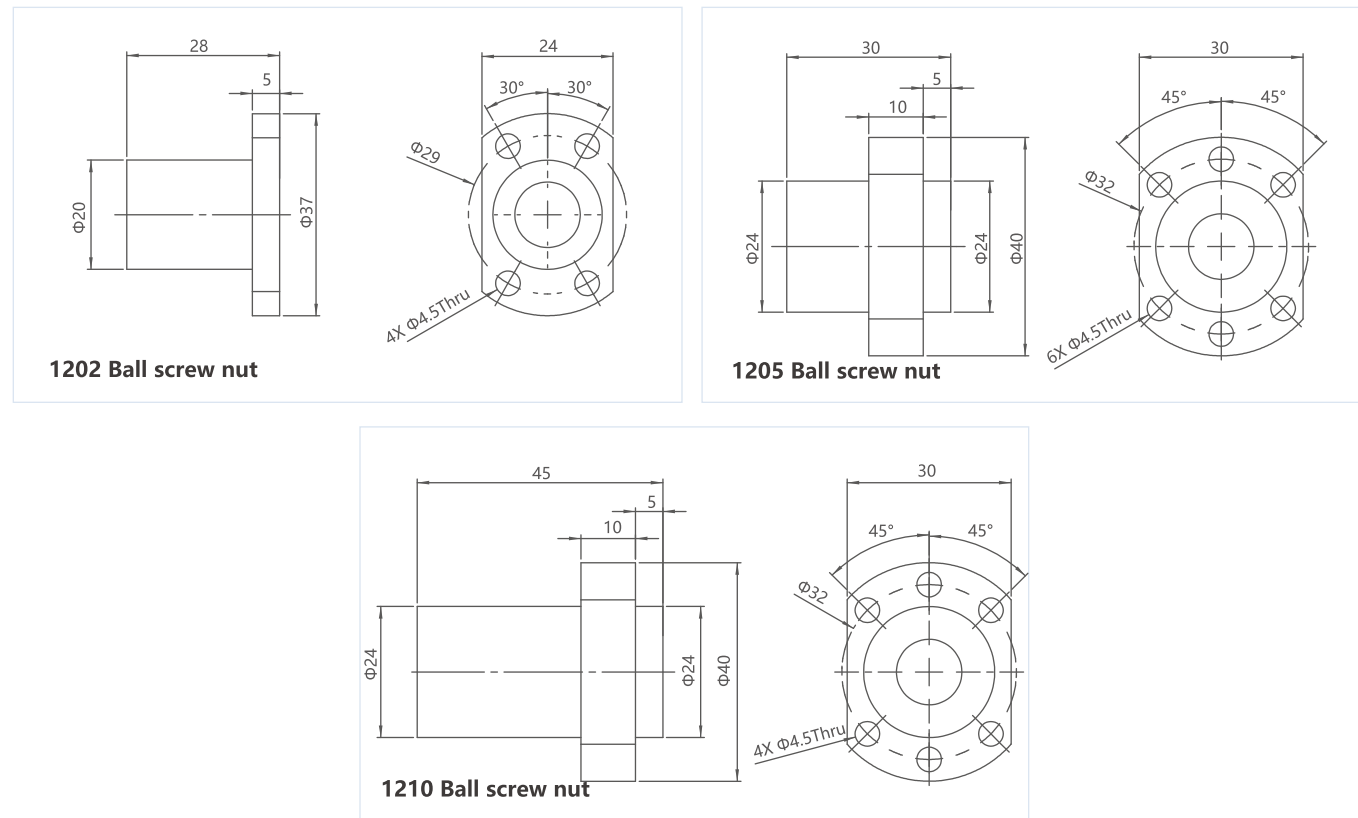

57mm(Size23) Series Ball Screw Actuator , Double Stack

Electrical Parameter

Size 23: 57mm (2.3") Ball screw actuator (1.8°Step Angle)			
Part No.	External	57E2*	
Wiring	Bipolar		
Wiring Voltage	3.25VDC	5VDC	12VDC
Current/Phase	3.3A	2.2A	0.9A
Resistance/Phase	0.98Ω	2.31Ω	13.33Ω
Inductance/Phase	3.2mH	7.6mH	35mH
Power Consumption/Total	25W		
Temperature Rise	135°F (75°C)		
Insulation Class	Class B (Class F optional)		
Insulation Resistance	20MΩ		



Outline

Force vs Pulse Curve

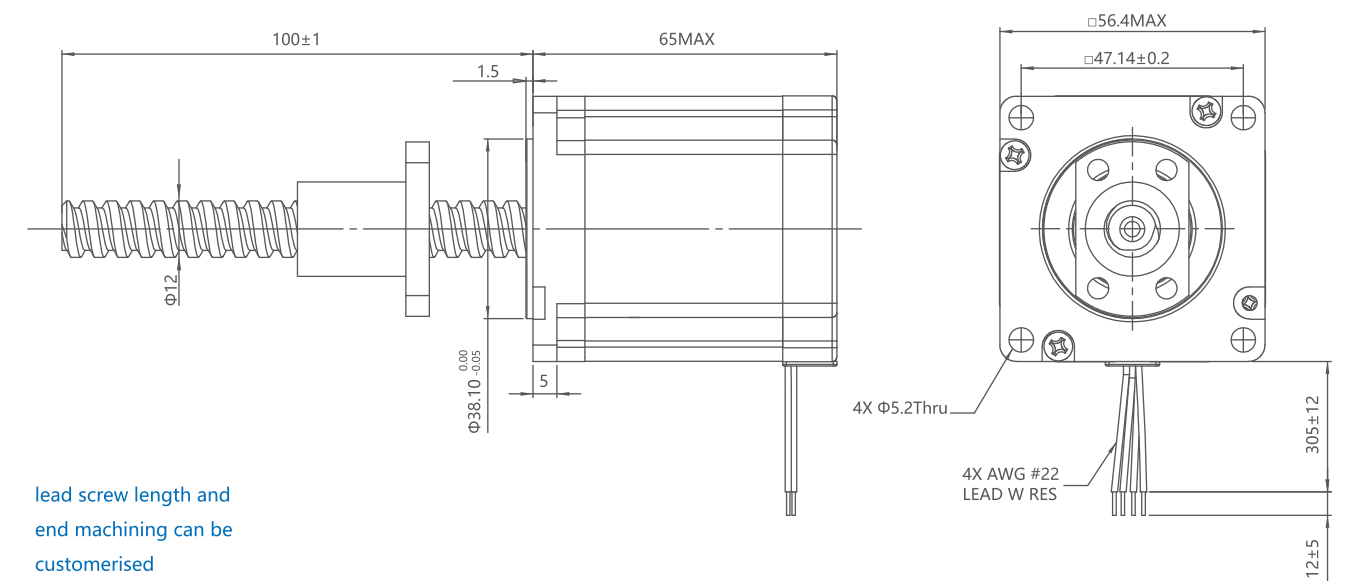
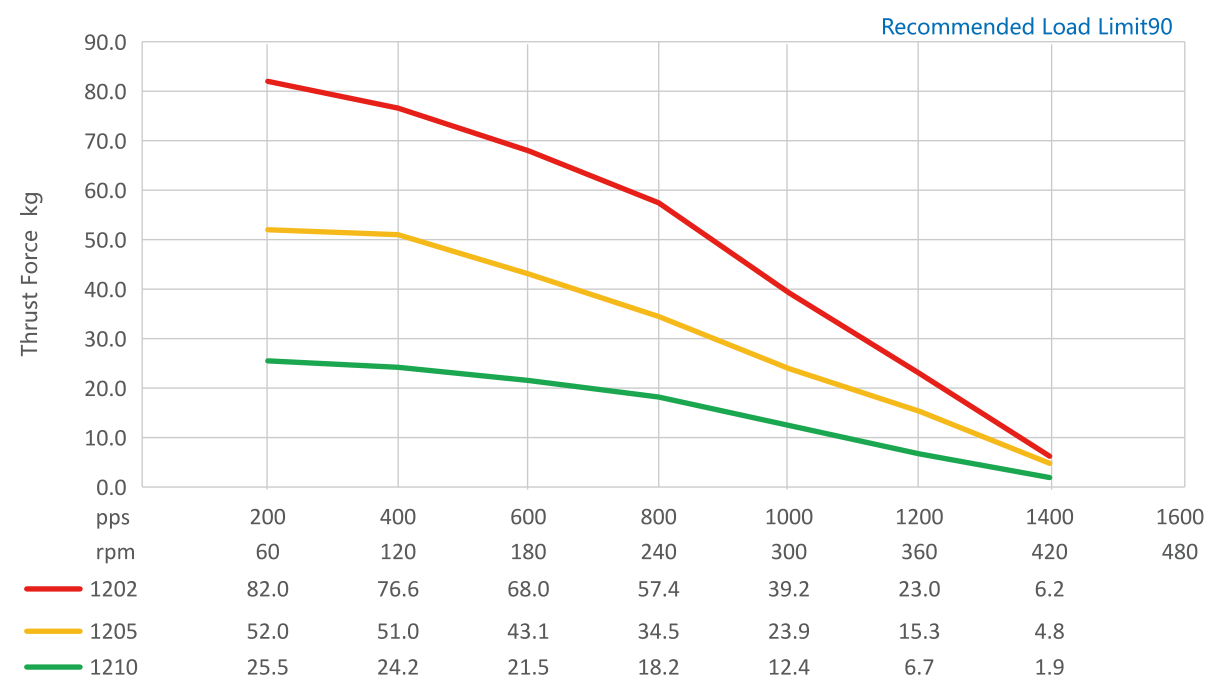

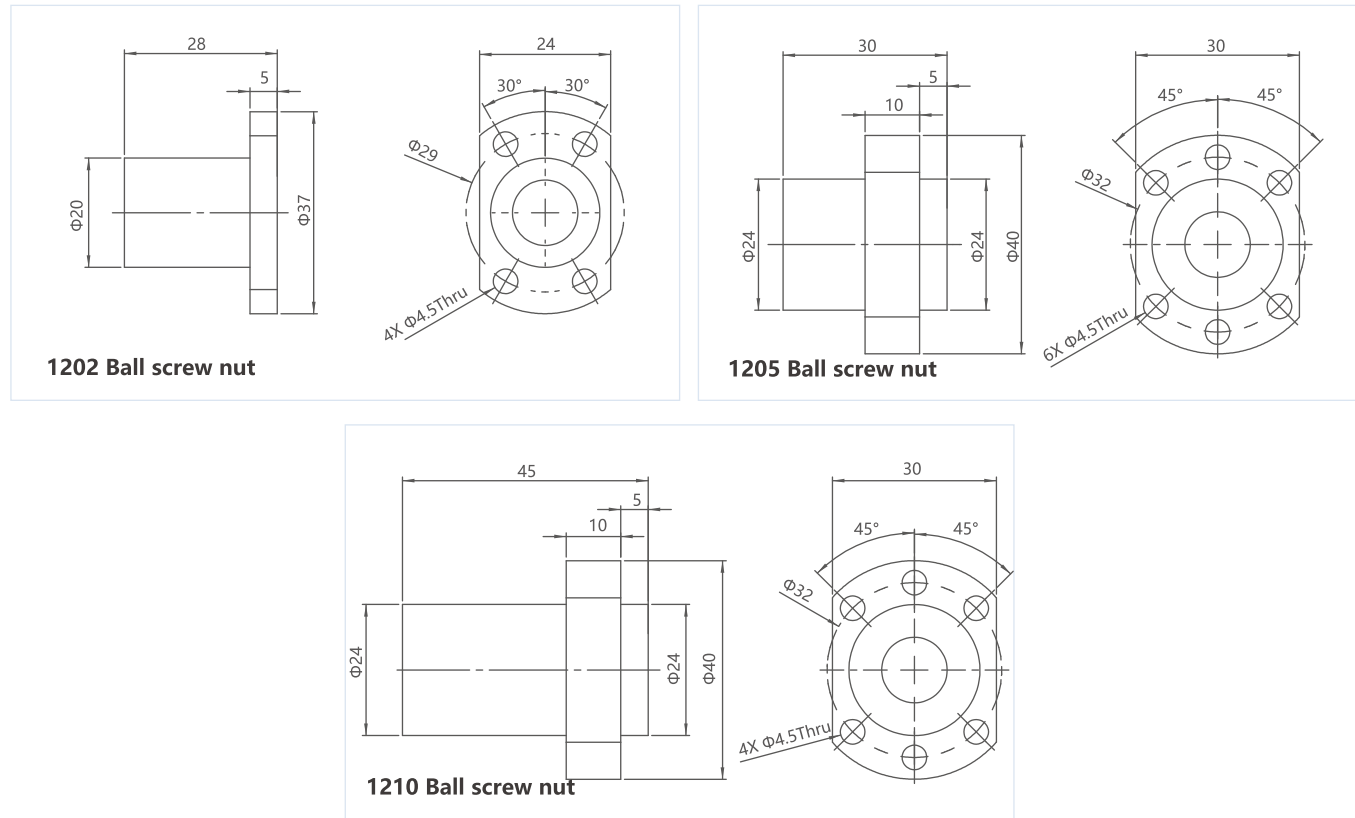

86mm(Size34) Series Ball Screw Actuator

Electrical Parameter

Size 34: 86mm (3.4") Ball screw actuator (1.8°Step Angle)			
Part No.	External	86E1*	
Wiring	Bipolar		
Wiring Voltage	2.85VDC	5VDC	12VDC
Current/Phase	5.47A	3.12A	1.3A
Resistance/Phase	0.52Ω	1.6Ω	9.23Ω
Inductance/Phase	2.86mH	8.8mH	51mH
Power Consumption/Total	31.2W		
Temperature Rise	135°F (75°C)		
Insulation Class	Class B (Class F optional)		
Insulation Resistance	20MΩ		



Outline

Force vs Pulse Curve

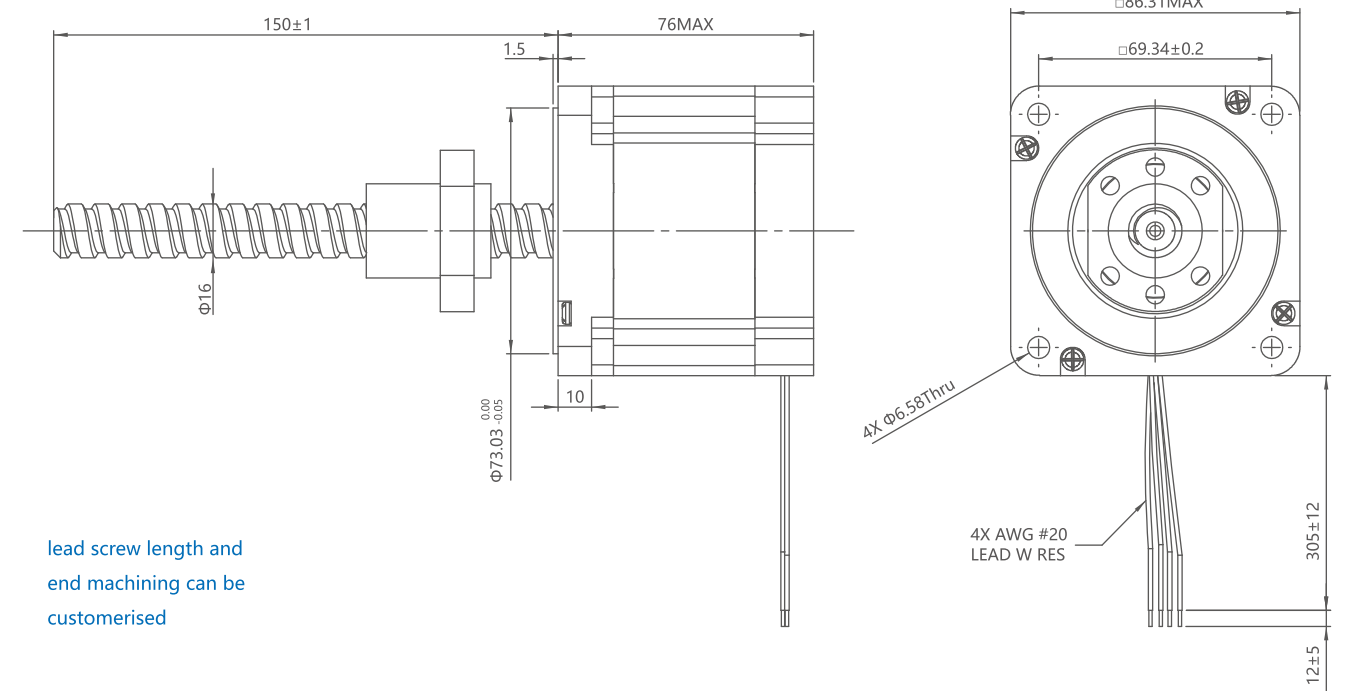
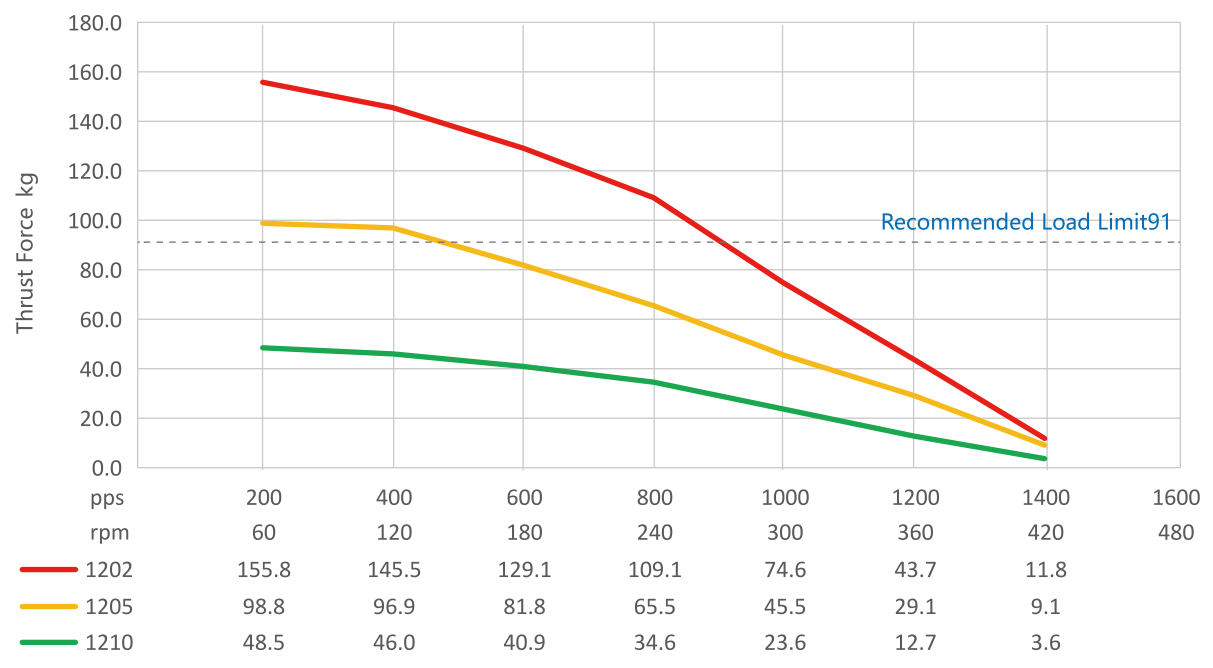

lead screw length and end machining can be customised

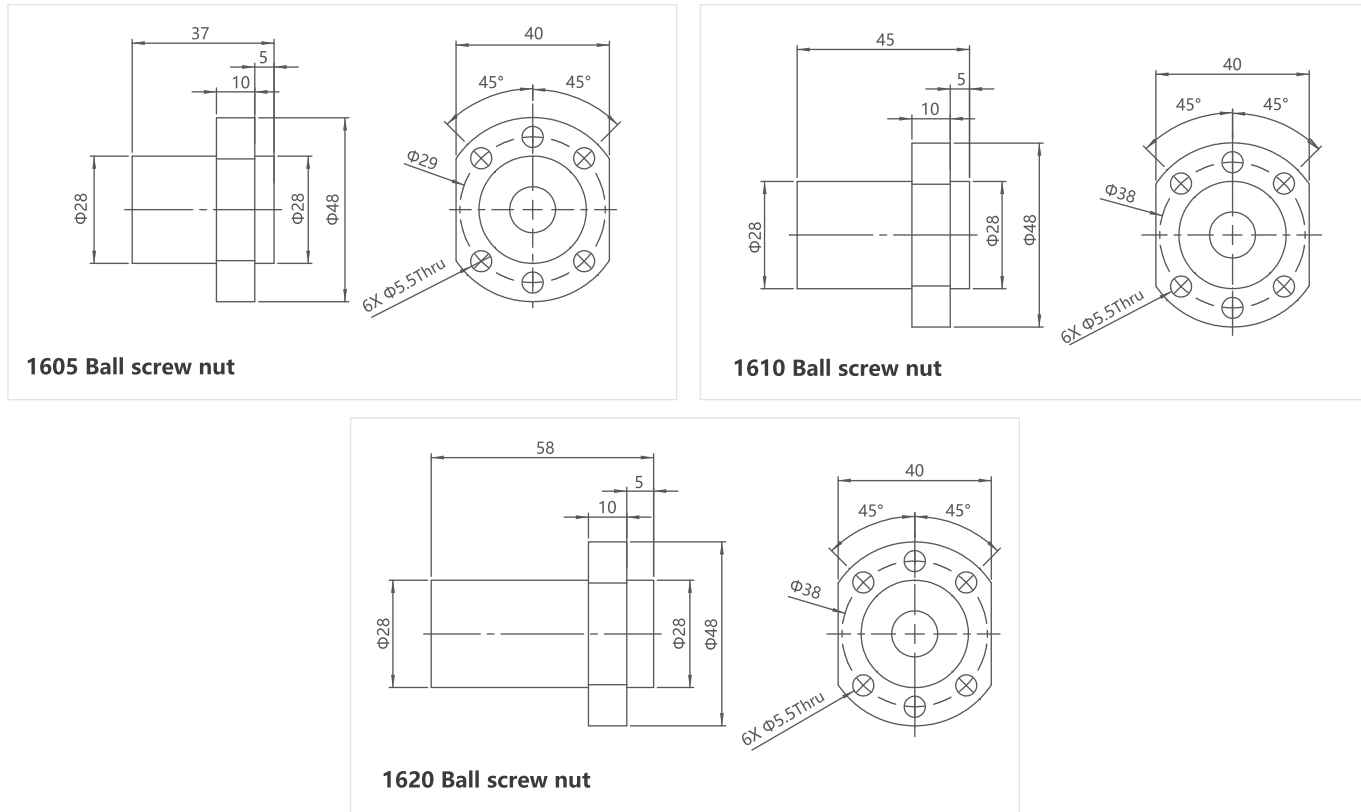

Stepper Motor Series



Force vs Pulse Curve

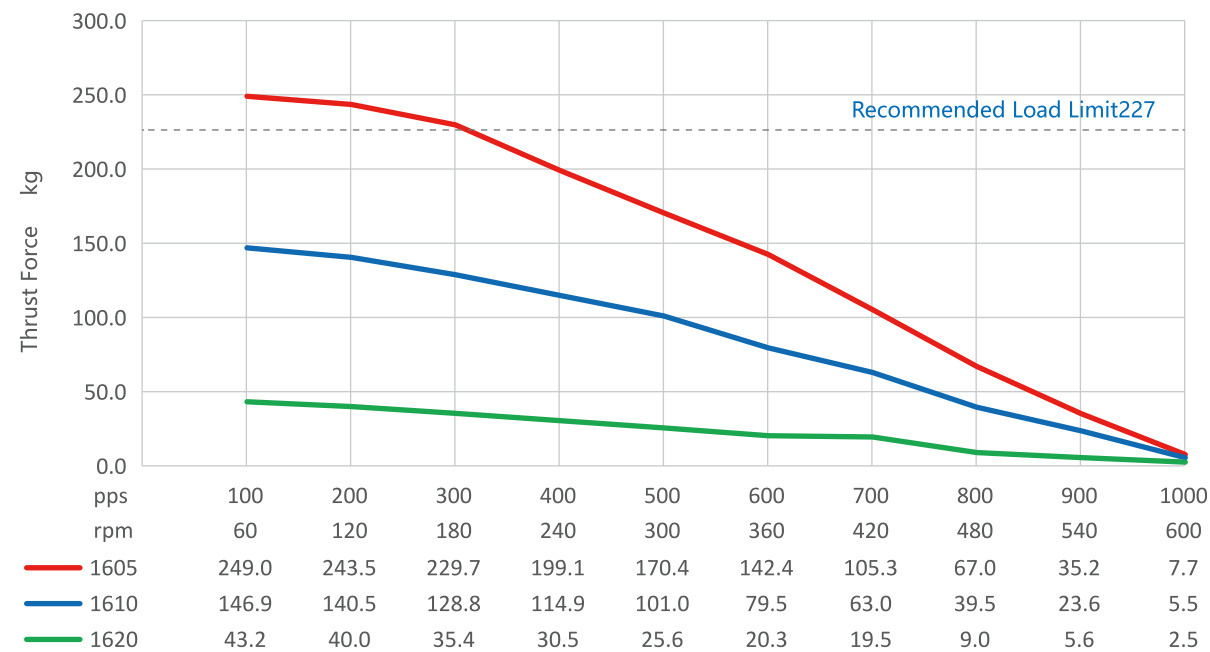

14mm Series Stepper Motor

Electrical performance

Item	parameter
Step Angle accuracy	±5%
Resistance accuracy	±10%
Inductance accuracy	±20%
Temperature rise	80K Max
Insulation grade	Class B (Class F optional)
Ambient temperature	-20°C~50°C
Insulation resistance	100MΩ Min.@500VDC
Dielectric strength	1Min@250VAC · 5mA Max
Radial run-out	0.06Max.@450g
Axial runout	0.08Max.@100g

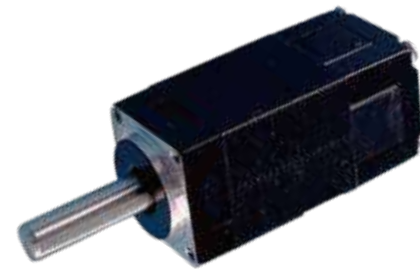

Electrical specification

Part Number	Wiring	Voltage	Current	Resistance	Inductance	Holding torque		Lead wires	Rotor inertia	Weight	length
		V	A	Ω	mH	oz-in	kgf·cm			kg	
14HS1021-0150	Bipolar	6.6	0.3	22	4	0.8	0.058	4	0.5	0.03	30

Out line

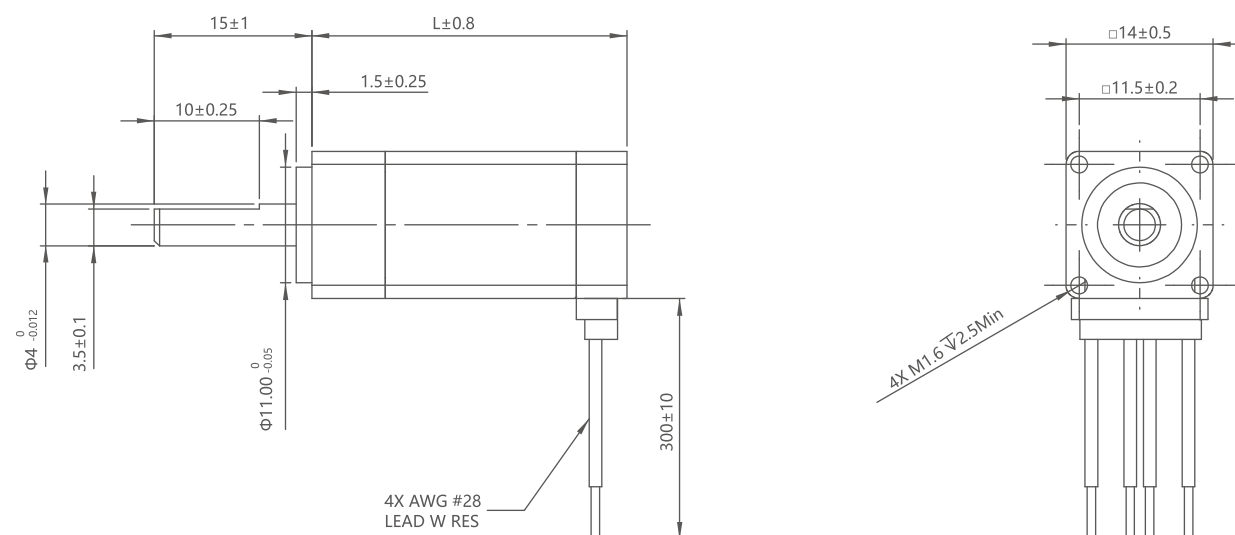

Pulse vs Torque Curve

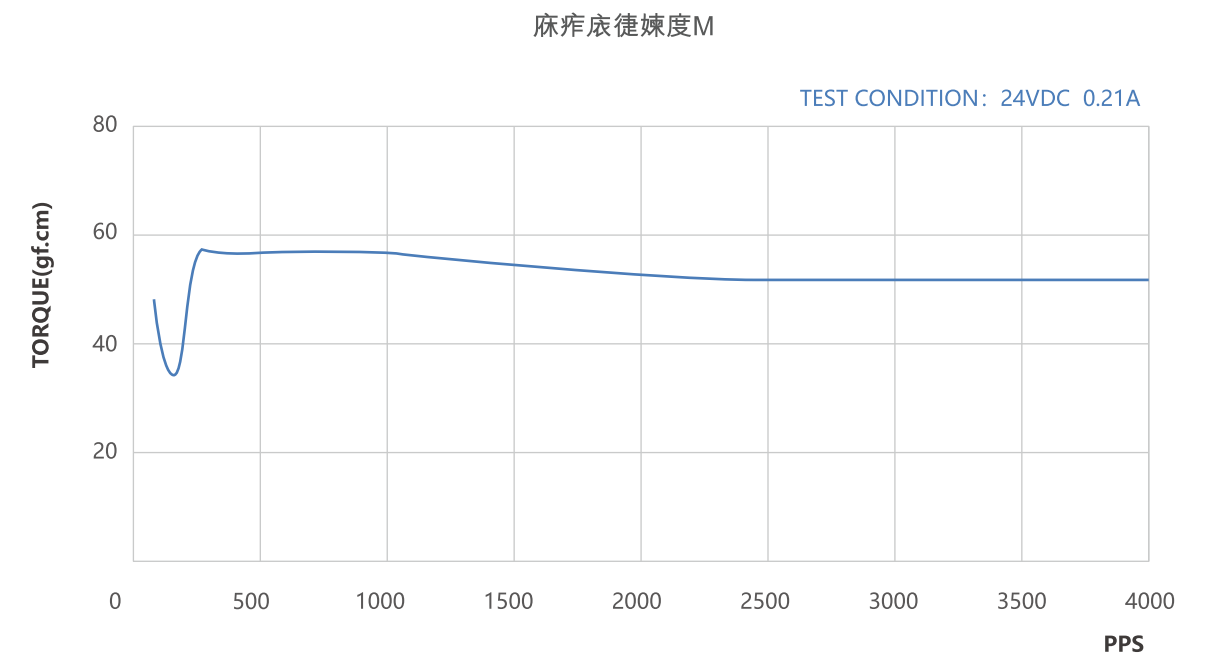

20mm Series Stepper Motor

Electrical performance

Item	parameter
Step Angle accuracy	±5%
Resistance accuracy	±10%
Inductance accuracy	±20%
Temperature rise	80K Max
Insulation grade	Class B (Class F optional)
Ambient temperature	-20°C~50°C
Insulation resistance	100MΩ Min.@500VDC
Dielectric strength	1Min.@250VAC · 5mA Max
Radial run-out	0.06Max.@450g
Axial runout	0.08Max.@100g



Electrical specification

Part Number	Wiring	Voltage V	Current A	Resistance Ω	Inductance mH	Holding torque		Lead wires	Rotor inertia g·cm ²	Weight kg	length mm
						oz-in	kgf·cm				
20HS1020-0100	Bipolar	4.8	0.2	24	8	1.8	0.13	4	2.5	0.05	28
20HS2060-0100	Bipolar	6	0.6	10	5.5	5.6	0.4	4	3.3	0.08	38

Out line

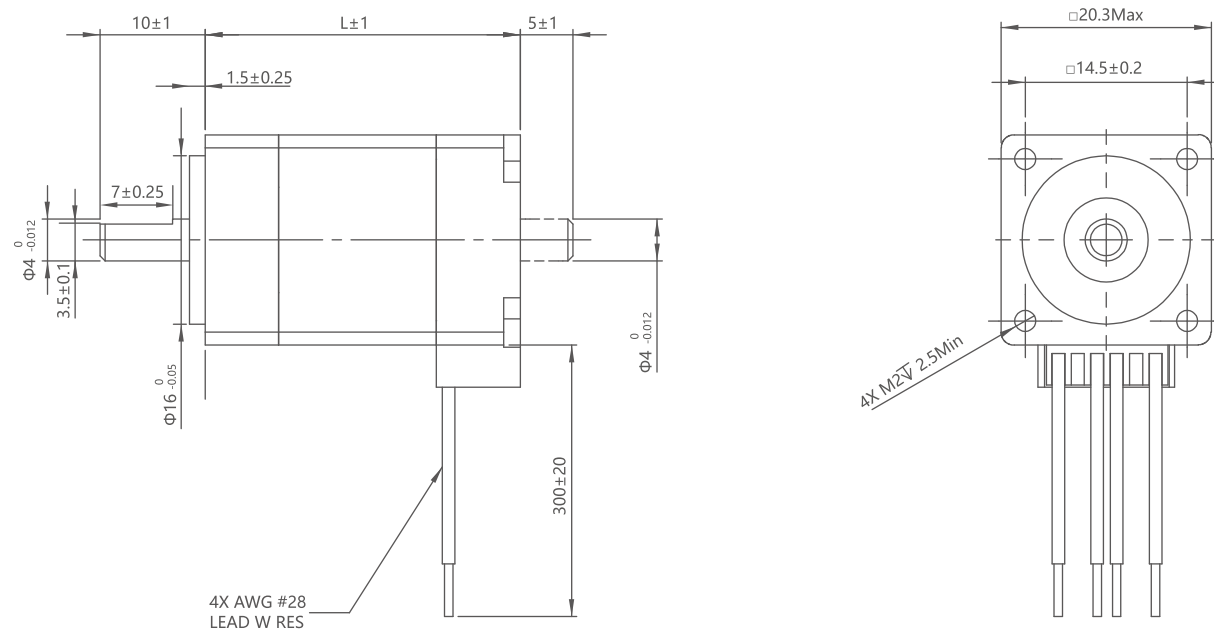

Pulse vs Torque Curve

御作依御煉底M

TEST CONDITION: 24VDC 0.2A

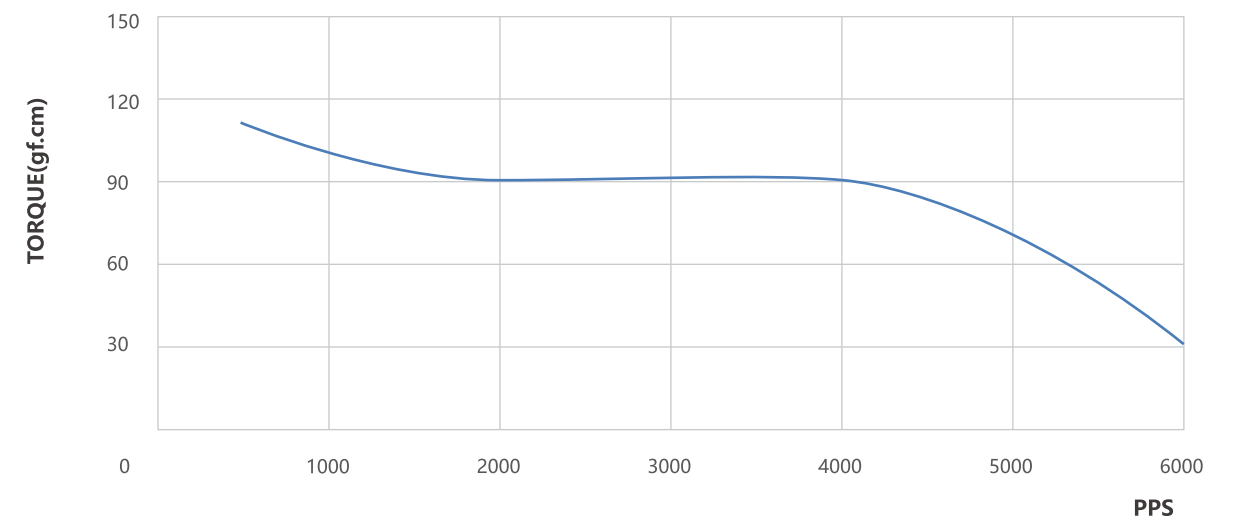

御作御採煉底M

TEST CONDITION: 24VDC 0.6A

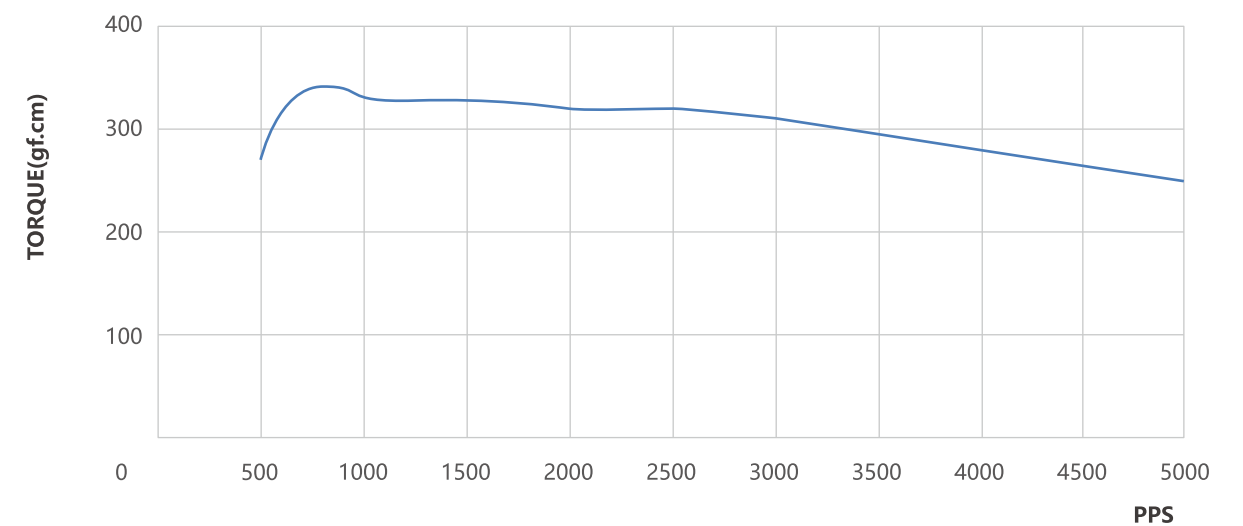

28mm Series Stepper Motor

Electrical performance

Item	parameter
Step Angle accuracy	±5%
Resistance accuracy	±10%
Inductance accuracy	±20%
Temperature rise	80K Max
Insulation grade	Class B (Class F optional)
Ambient temperature	-20°C~50°C
Insulation resistance	100MΩ Min.@500VDC
Dielectric strength	1Min.@500VAC · 5mA Max
Radial run-out	0.06Max.@450g
Axial runout	0.08Max.@200g



Electrical specification

Part Number	Wiring	Voltage V	Current A	Resistance Ω	Inductance mH	Holding torque		Lead wires	Rotor inertia g·cm ²	Weight kg	length mm
						oz-in	kgf·cm				
28HS1067-0200	Bipolar	3.75	0.67	5.6	8.8	8.8	0.63	4	9	0.11	32
28HS2067-0200	Bipolar	4.56	0.67	6.8	5.8	13.2	0.95	4	12	0.14	45

Out line

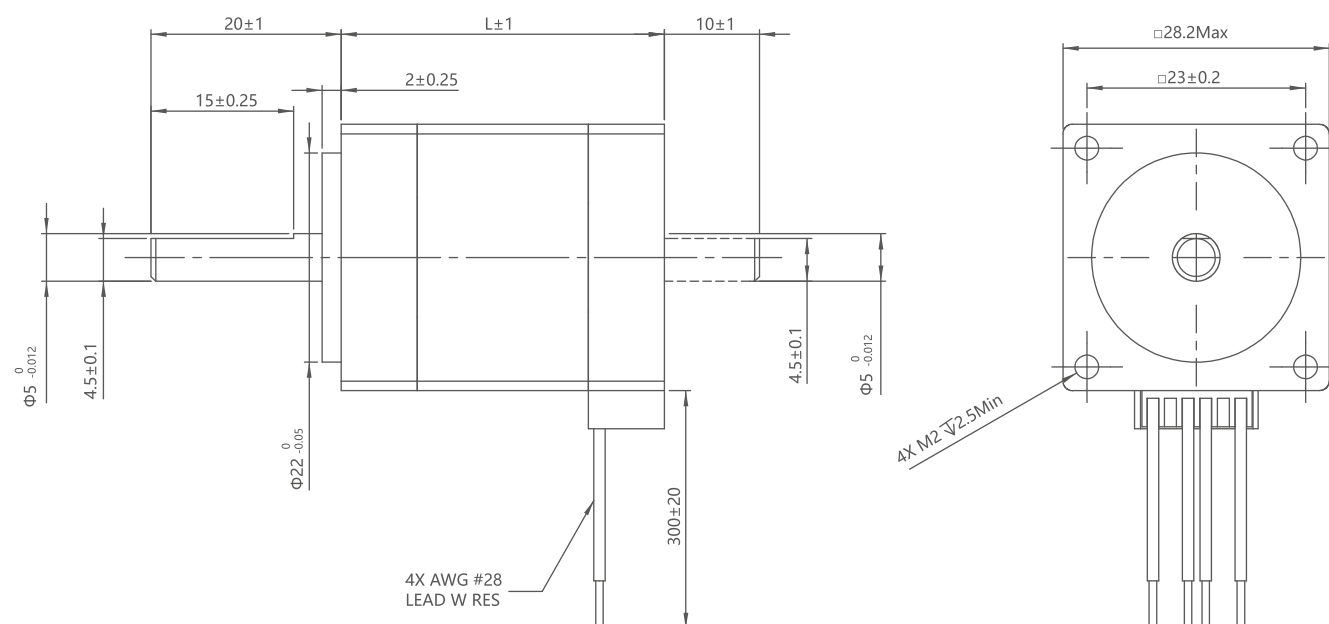

Pulse vs Torque Curve

28HS1067-0200

TEST CONDITION: 24VDC 0.67A

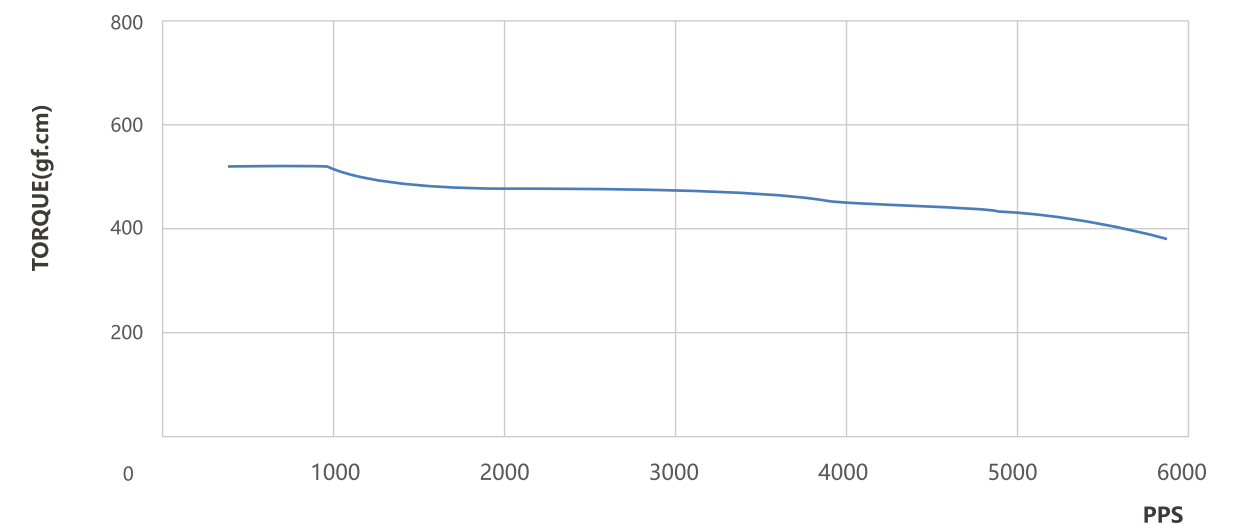
28HS2067-0200

TEST CONDITION: 24VDC 0.67A

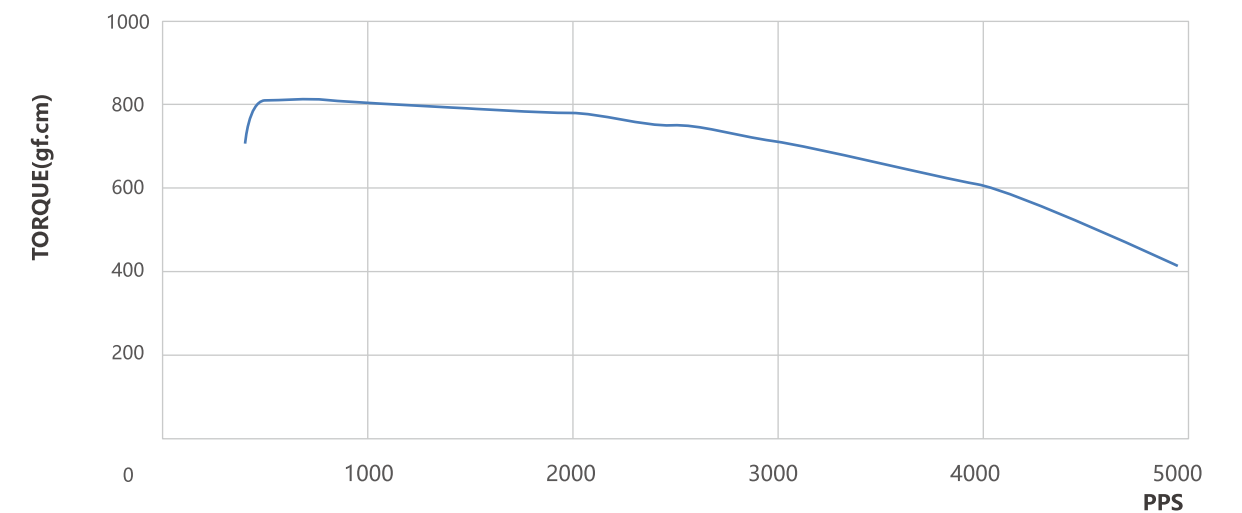

35mm Series Stepper Motor

Electrical performance

Item	parameter
Step Angle accuracy	±5%
Resistance accuracy	±10%
Inductance accuracy	±20%
Temperature rise	80K Max
Insulation grade	Class B (Class F optional)
Ambient temperature	-10°C~50°C
Insulation resistance	100MΩ Min.@500VDC
Dielectric strength	1Min.@500VAC · 5mA Max
Radial run-out	0.06Max.@450g
Axial runout	0.08Max.@450g



Electrical specification

Part Number	Wiring	Voltage V	Current A	Resistance Ω	Inductance mH	Holding torque		Lead wires	Rotor inertia g·cm ²	Weight kg	length mm
						oz-in	kgf·cm				
35HS1070-0240	Bipolar	4.6	0.7	6.5	9.4	25	1.8	4	14	0.16	33
35HS2100-0240	Bipolar	7	1	7	12	51.4	3.7	4	22	0.23	47

Out line

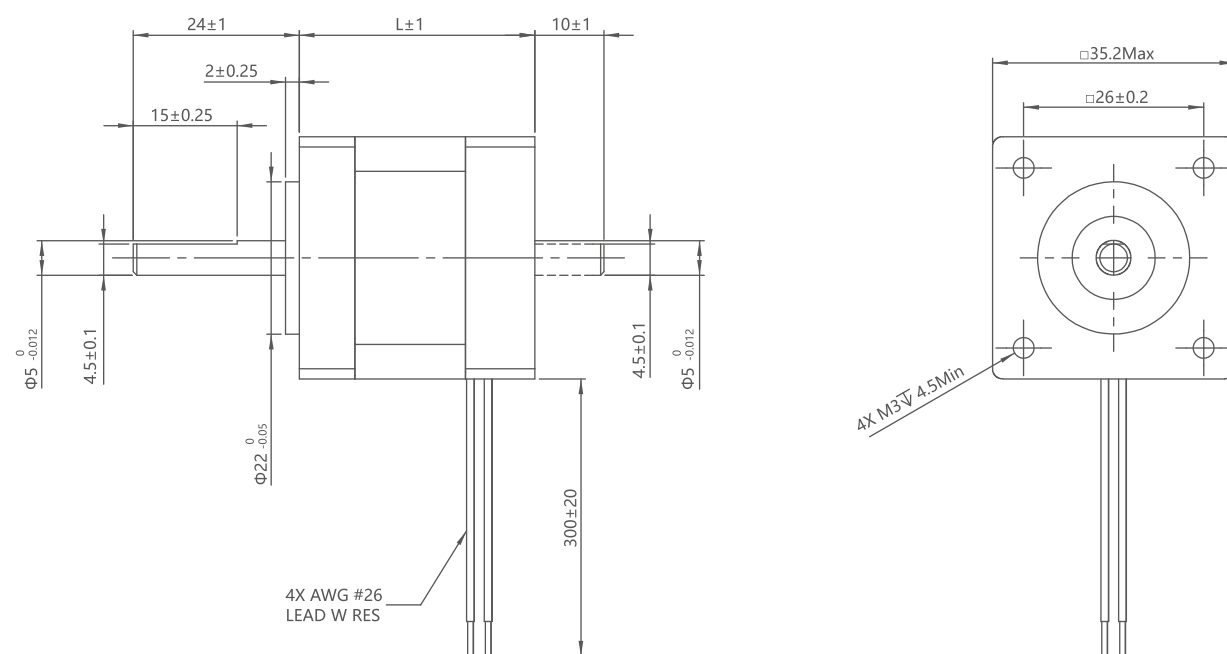

Pulse vs Torque Curve

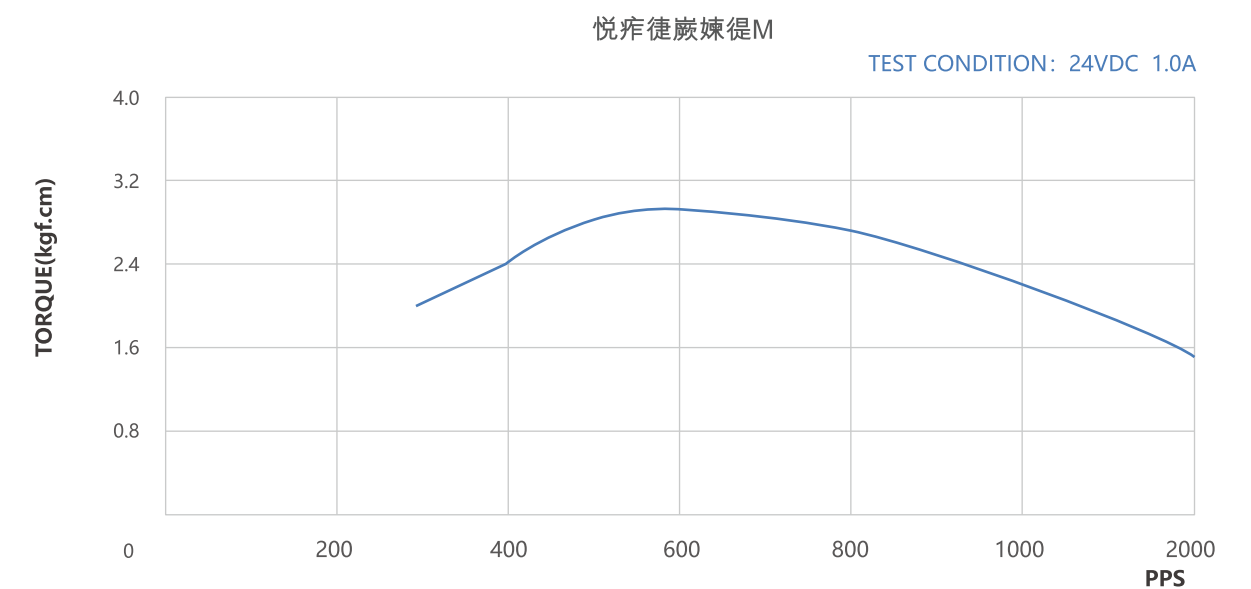
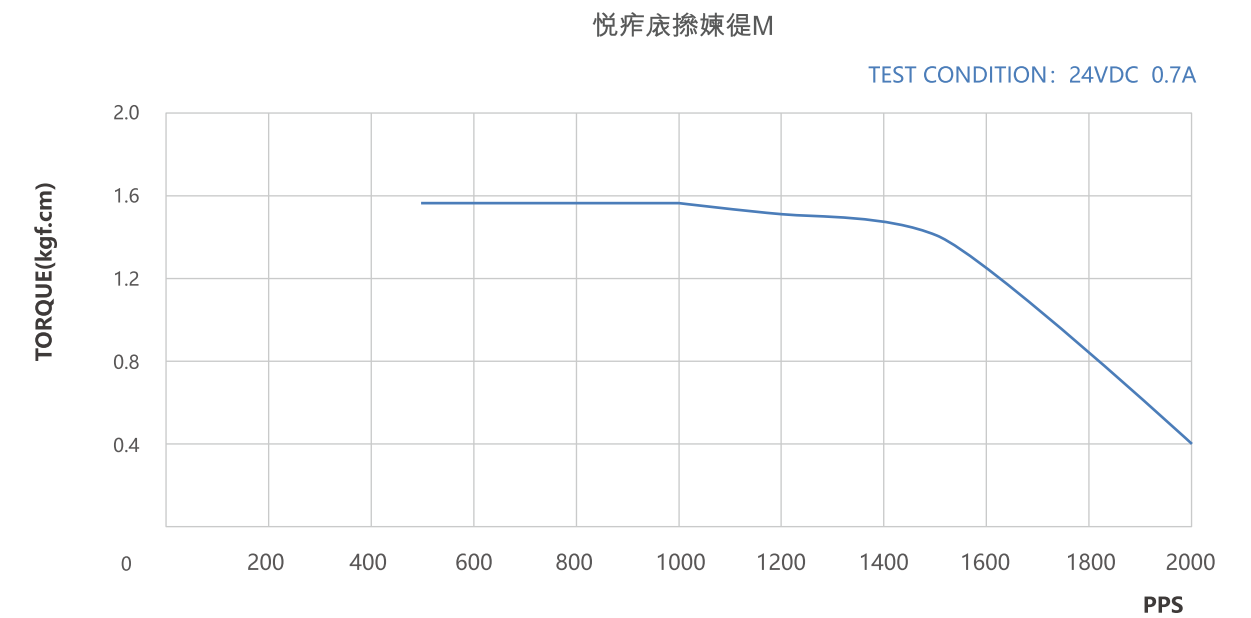

42mm Series Stepper Motor

Electrical performance

Item	parameter
Step Angle accuracy	±5%
Resistance accuracy	±10%
Inductance accuracy	±20%
Temperature rise	80K Max
Insulation grade	Class B (Class F optional)
Ambient temperature	-10°C~50°C
Insulation resistance	100MΩ Min.@500VDC
Dielectric strength	1Min.@500VAC · 5mA Max
Radial run-out	0.06Max.@450g
Axial runout	0.08Max.@450g



Electrical specification

Part Number	Wiring	Voltage V	Current A	Resistance Ω	Inductance mH	Holding torque		Lead wires	Rotor inertia g·cm ²	Weight kg	length mm
						oz-in	kgf·cm				
42HS1133-0240	Bipolar	2.8	1.33	2.1	2.5	33.3	2.4	4	35	0.22	33
42HS2168-0240	Bipolar	2.8	1.68	1.65	3.2	52.8	3.8	4	54	0.28	39
42HS3150-0240	Bipolar	3.5	1.5	2.3	4.6	77.8	5.6	4	68	0.35	47
42HS4150-0240	Bipolar	3.8	1.5	2.5	6.5	95.8	6.9	4	80	0.43	57

Out line

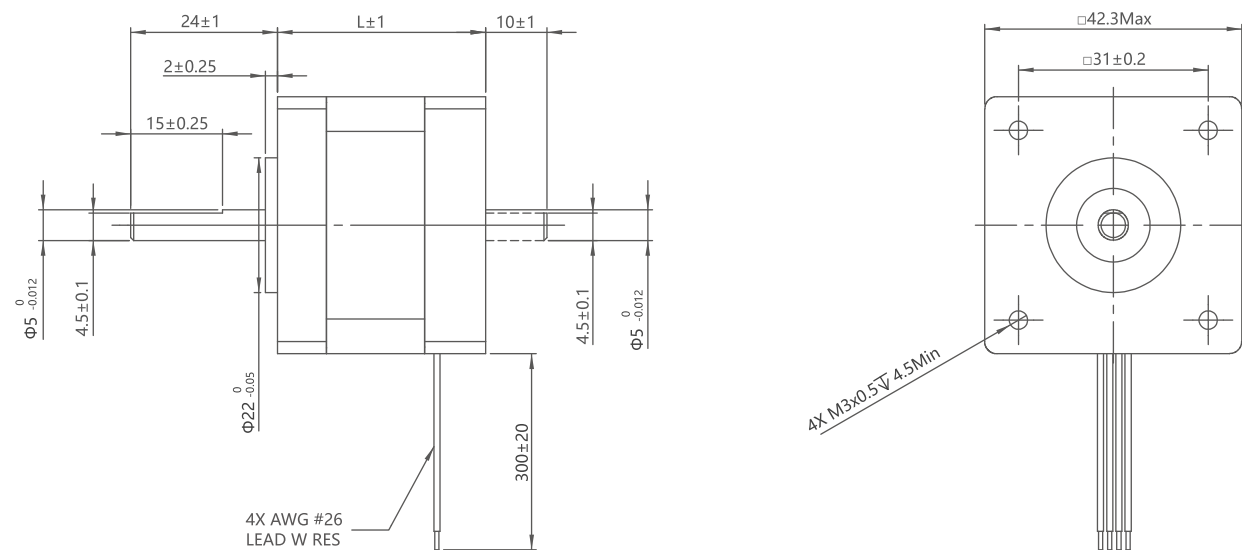

Pulse vs Torque Curve

懽杵搧懨媠倣M

TEST CONDITION: 24VDC 1.33A

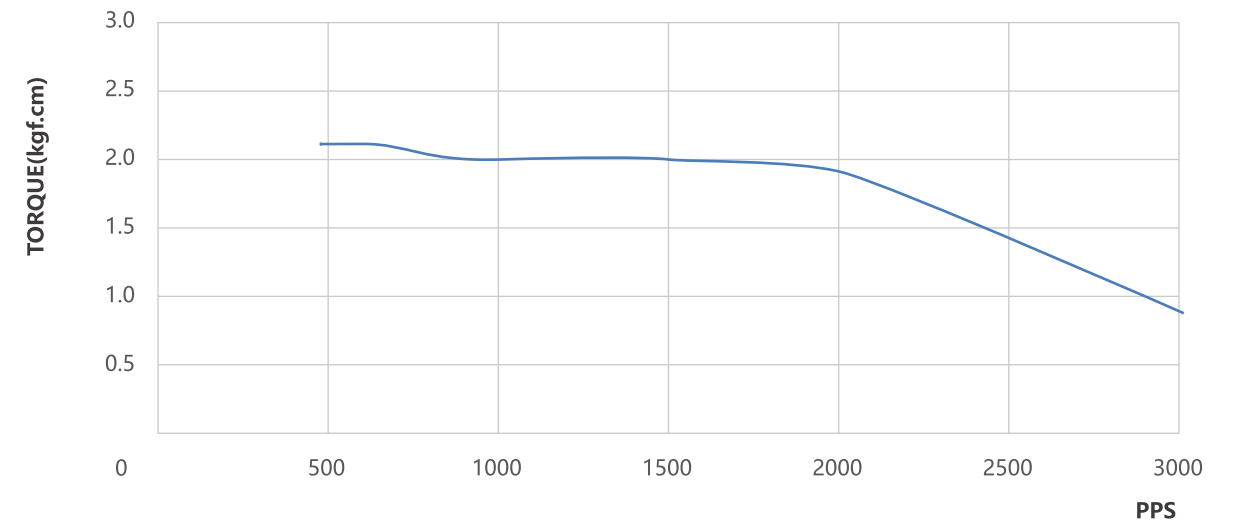

懽杵倣掩媠倣M

TEST CONDITION: 24VDC 1.68A

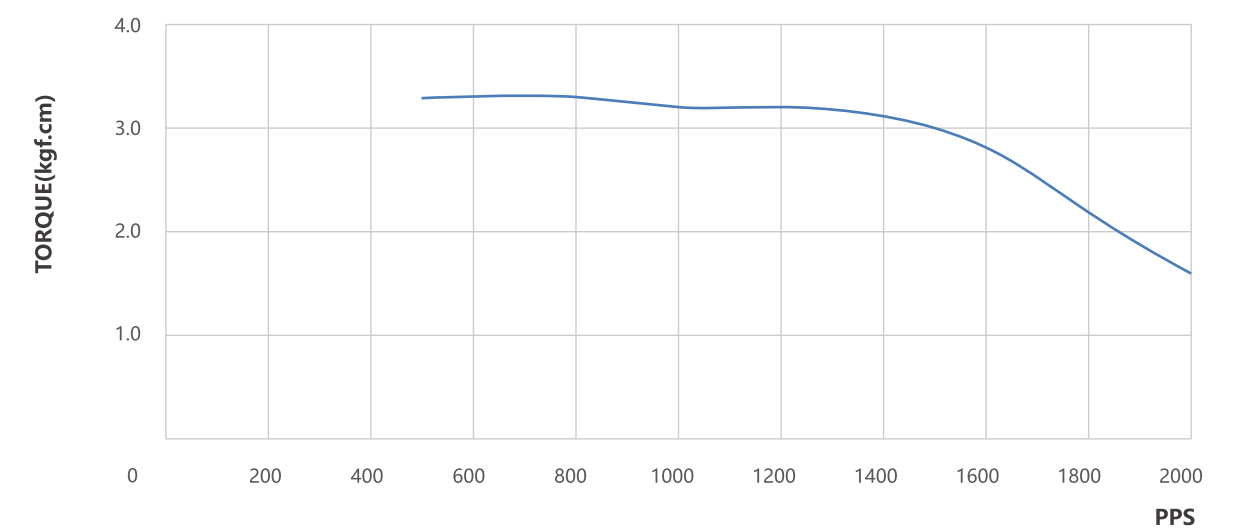

Pulse vs Torque Curve

懽瘡悝抡媾倣M

TEST CONDITION: 24VDC 1.5A

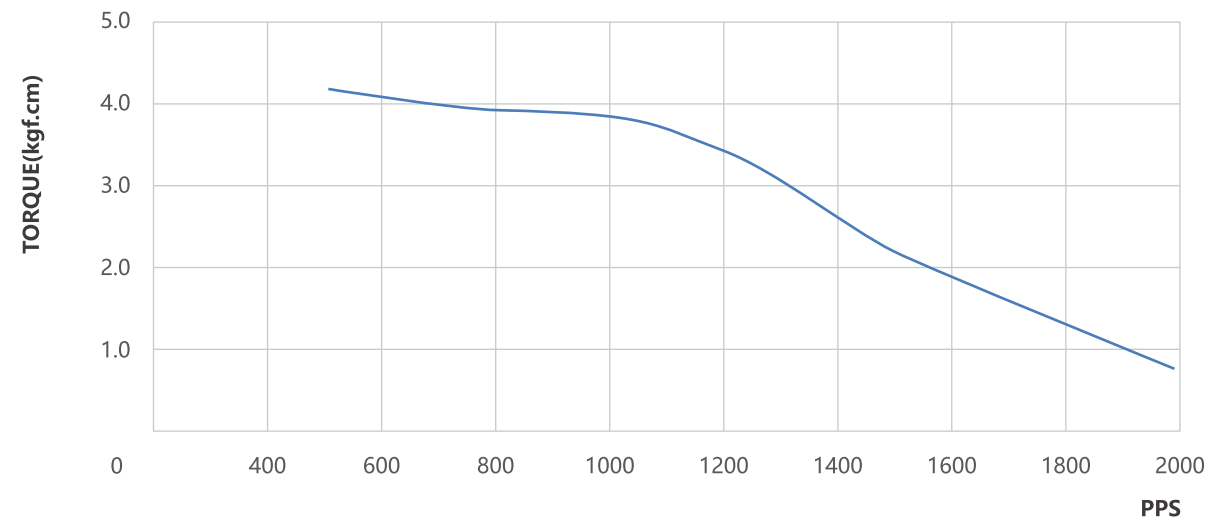

Bipolar

懽瘡悝抡媾倣M

TEST CONDITION: 24VDC 1.5A

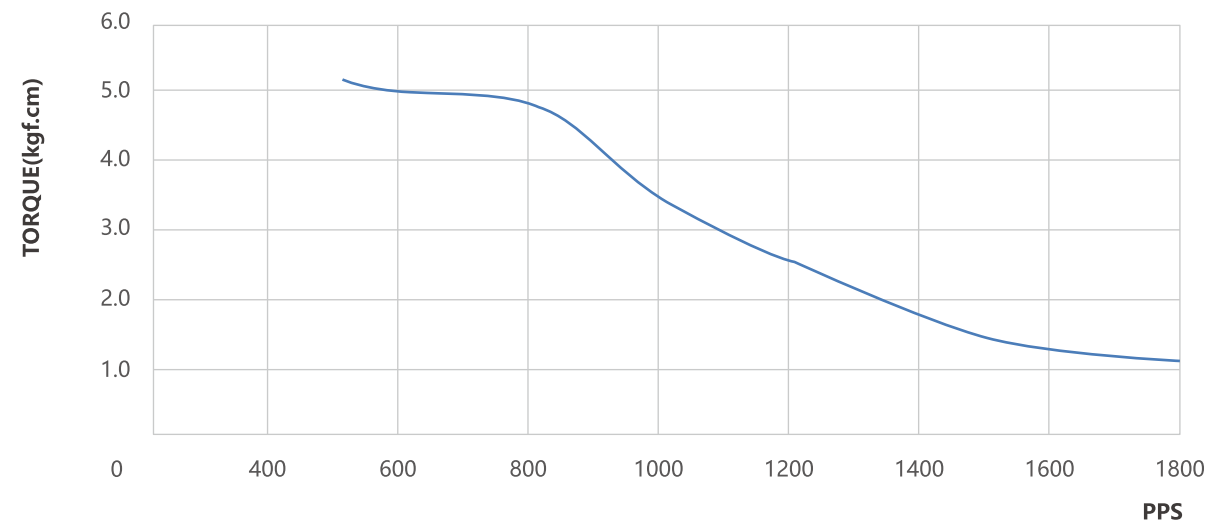

57mm Series Stepper Motor

Electrical performance

Item	parameter
Step Angle accuracy	±5%
Resistance accuracy	±10%
Inductance accuracy	±20%
Temperature rise	80K Max
Insulation grade	Class B (Class F optional)
Ambient temperature	-20°C~50°C
Insulation resistance	100MΩ Min.@500VDC
Dielectric strength	1Min.@500VAC · 5mA Max
Radial run-out	0.06Max.@450g
Axial runout	0.08Max.@450g



Electrical specification

Part Number	Wiring	Voltage V	Current A	Resistance Ω	Inductance mH	Holding torque		Lead wires	Rotor inertia g·cm ²	Weight kg	length mm
						oz-in	kgf·cm				
57HS1280-0210	Bipolar	2	2.8	0.7	1.4	72.2	5.2	4	120	0.47	41
57HS2280-0210	Bipolar	2.3	2.8	0.83	2.2	118	8.5	4	275	0.65	51
57HS3280-0210	Bipolar	2.5	2.8	0.9	2.5	142	10.2	4	300	0.7	55
57HS4280-0210	Bipolar	3.2	2.8	1.13	3.6	236	17	4	480	1	76

Out line

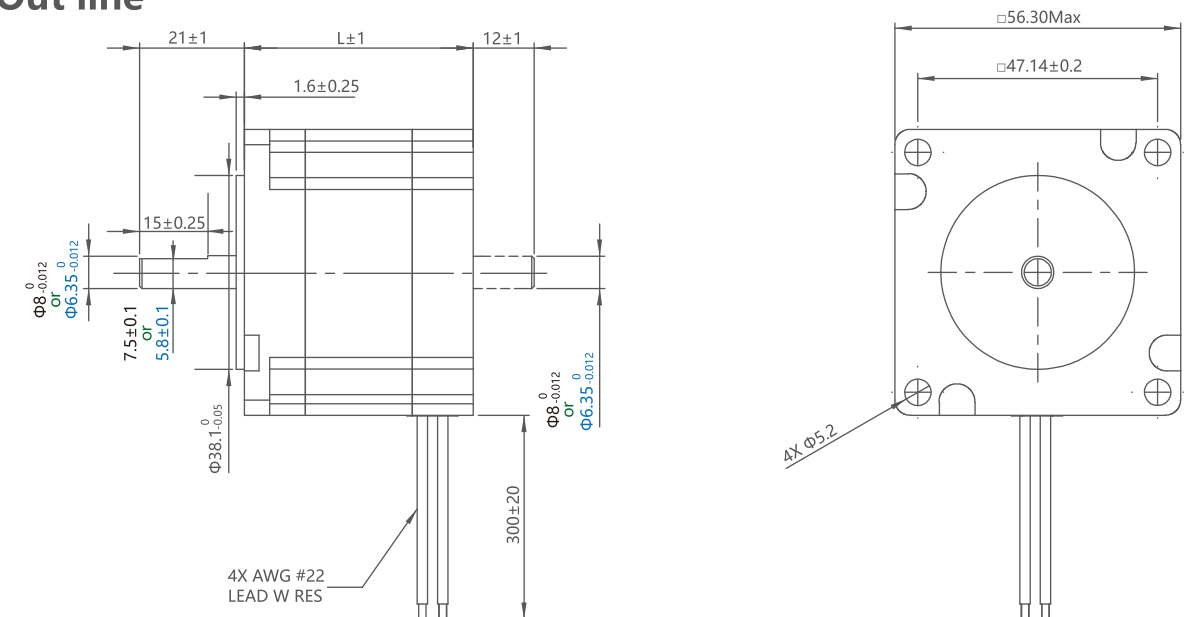

Pulse vs Torque Curve

評疋庖斡煉徒M

TEST CONDITION: 24VDC 2.8A

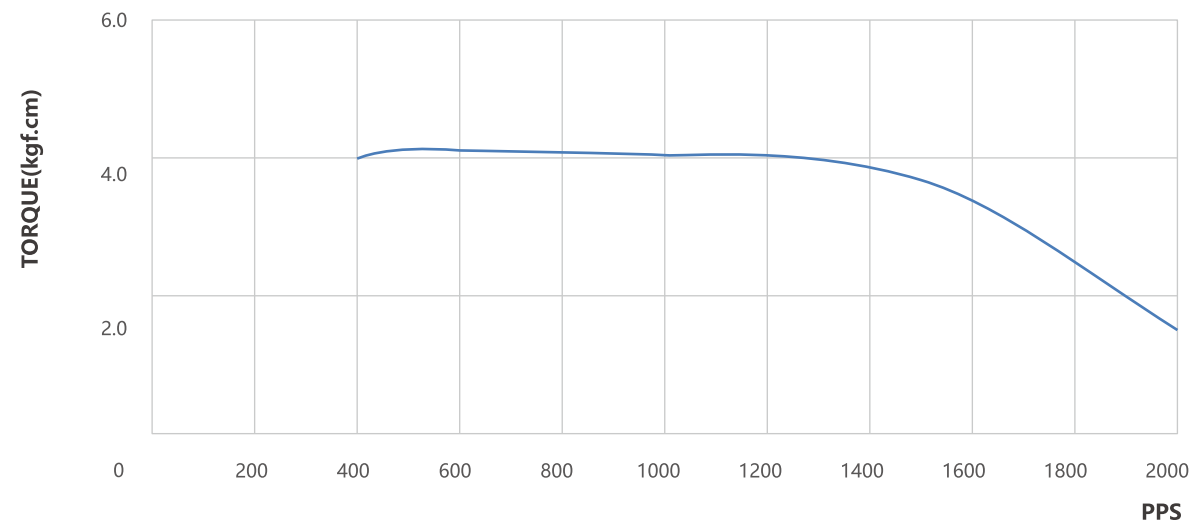

Pulse vs Torque Curve

評疋患斡煉徒M

TEST CONDITION: 24VDC 2.8A

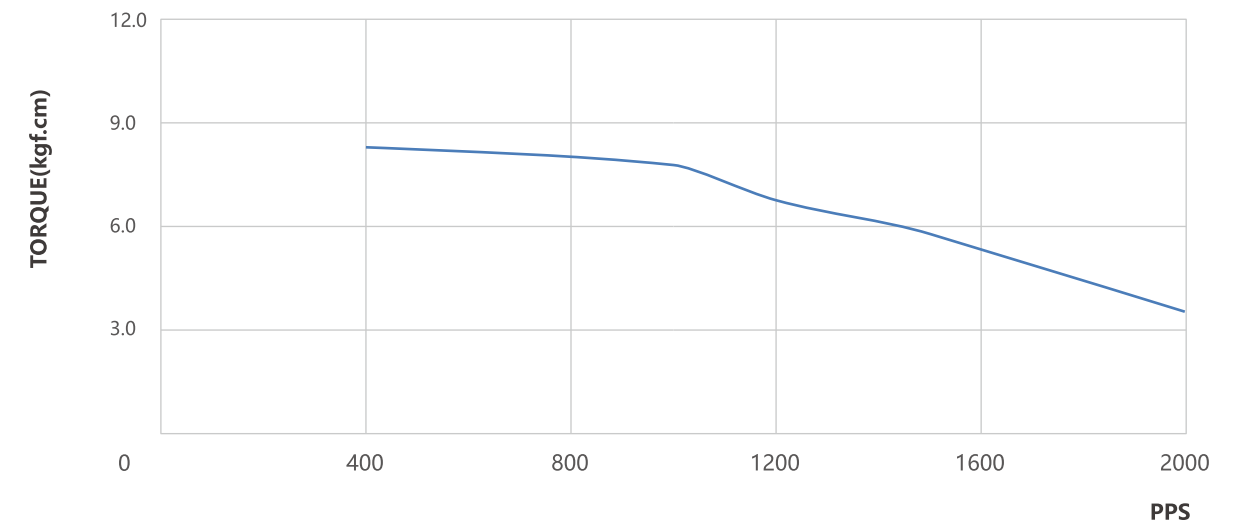

評疋借斡煉徒M

TEST CONDITION: 24VDC 2.8A

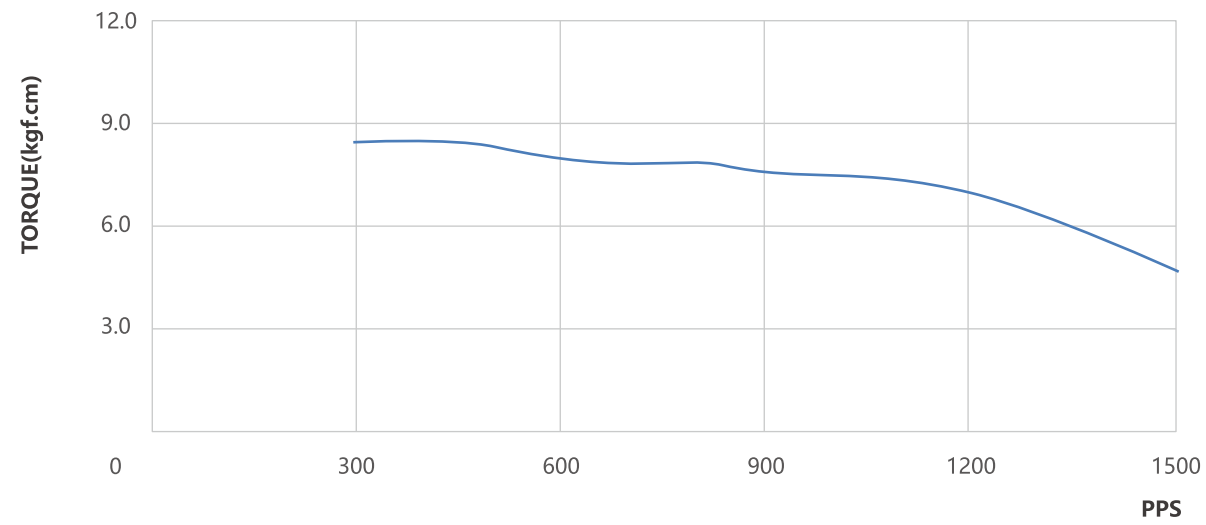

評疋播斡煉徒M

TEST CONDITION: 24VDC 2.8A

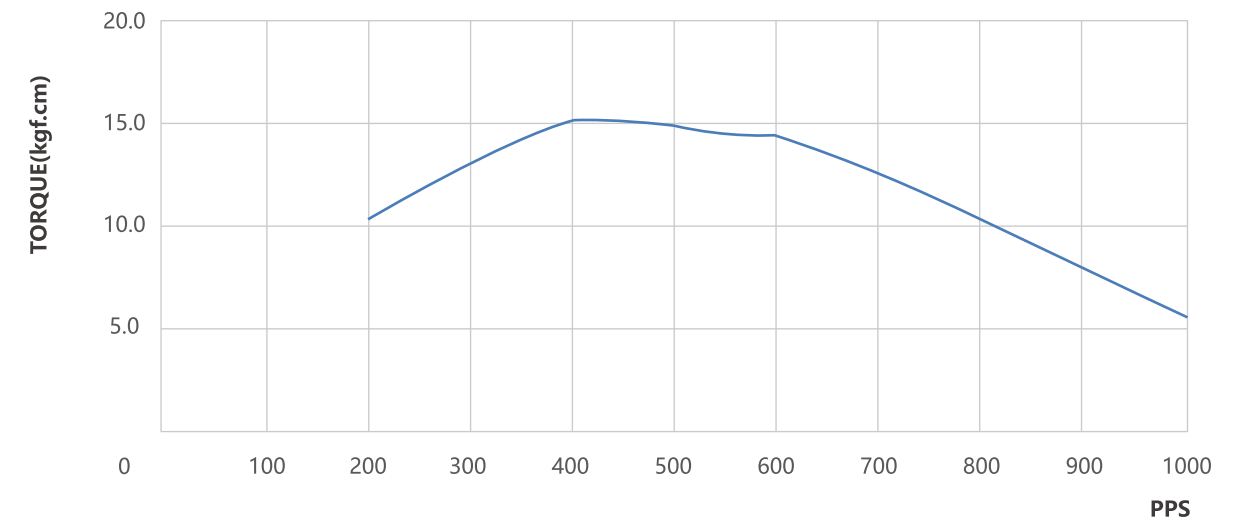

86mm Series Stepper Motor

Electrical performance

Item	parameter
Step Angle accuracy	±5%
Resistance accuracy	±10%
Inductance accuracy	±20%
Temperature rise	80K Max
Insulation grade	Class B (Class F optional)
Ambient temperature	-20°C~50°C
Insulation resistance	100MΩ Min.@500VDC
Dielectric strength	1Min.@500VAC · 5mA Max
Radial run-out	0.06Max.@450g
Axial runout	0.08Max.@450g



Electrical specification

Part Number	Wiring	Voltage V	Current A	Resistance Ω	Inductance mH	Holding torque		Lead wires	Rotor inertia g·cm ²	Weight kg	length mm
						oz-in	kgf·cm				
86HS1600-0370	Bipolar	1.44	6	0.24	1.27	357	25.7	4	600	1.6	66
86HS2300-0370	Bipolar	4.8	3	1.6	12.5	903	65	4	1200	2.5	99
86HS3600-0370	Bipolar	3.6	6	0.6	3.7	1194	86	4	1650	3.2	123

Out line

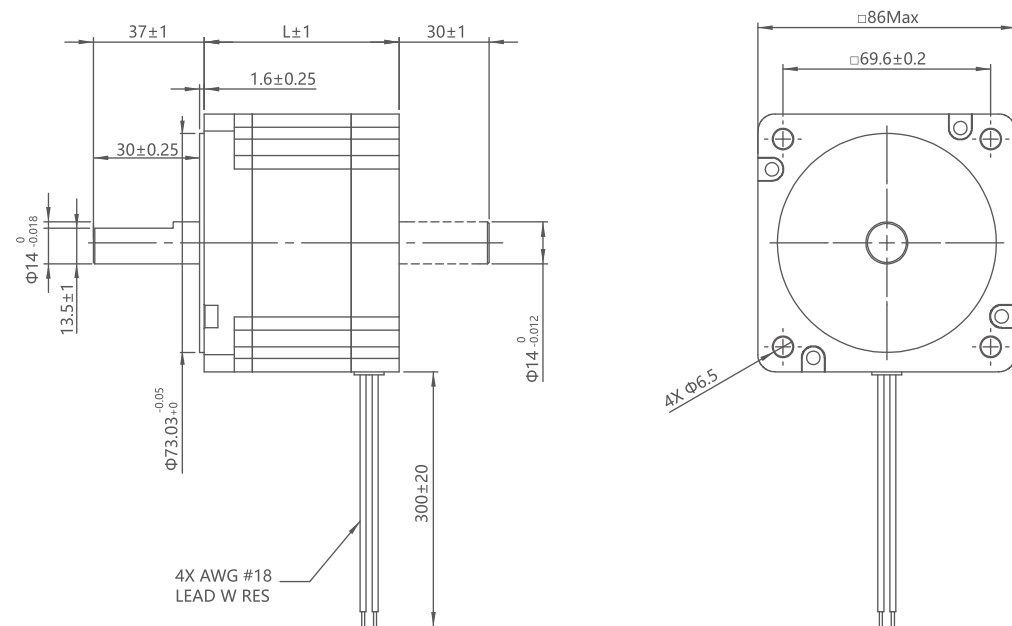

Pulse vs Torque Curve

斧疥座蕨嫌您M

TEST CONDITION: 30VDC 6.0A

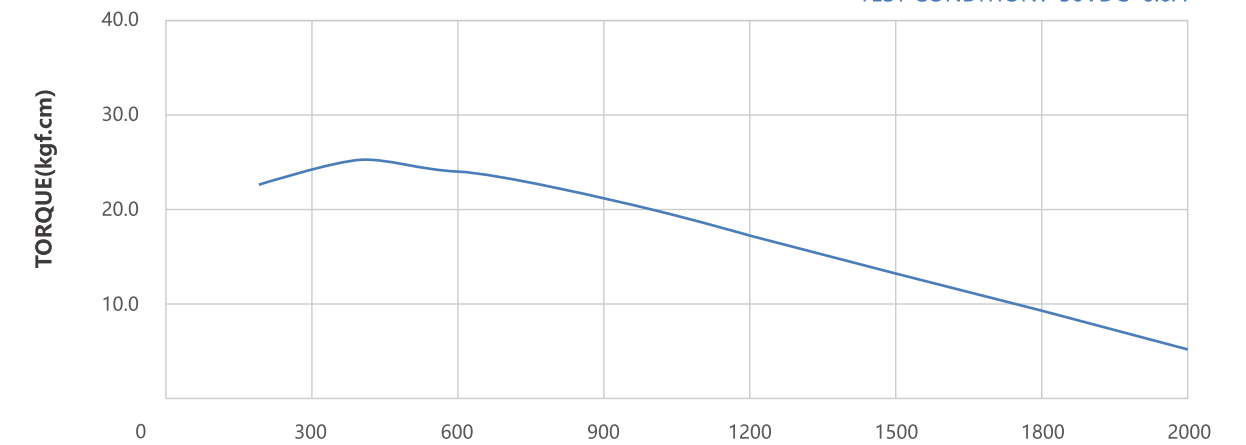

斧疥健蕨嫌您M

TEST CONDITION: 24VDC 3.0A

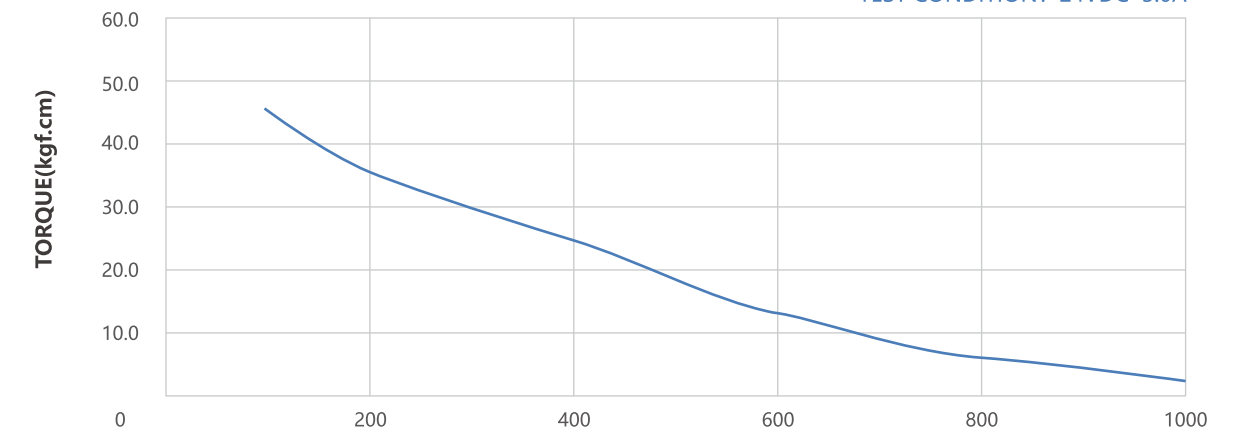

斧疥惺蕨嫌您M

TEST CONDITION: 24VDC 6.0A

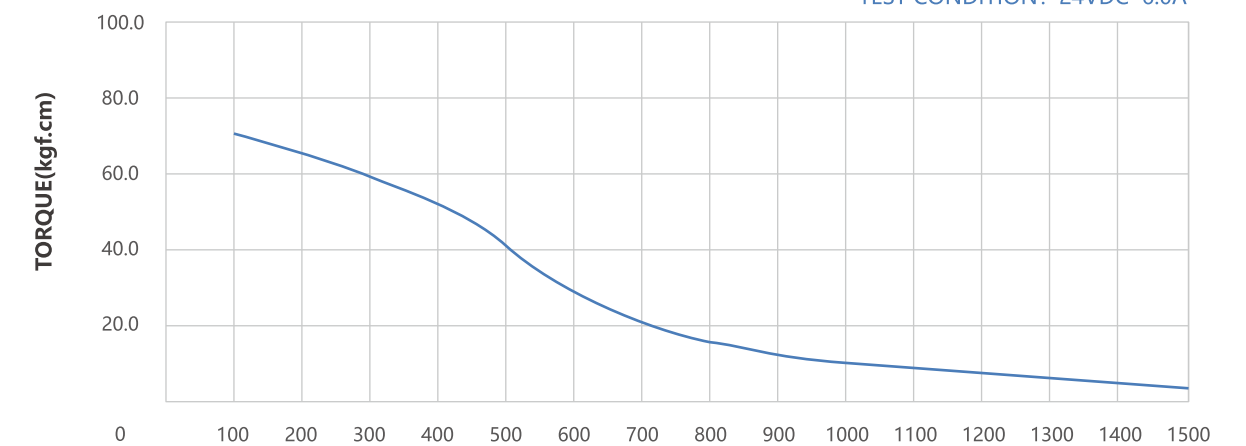

Linear Module Series

LM series modules with high accuracy, good rigidity and excellent load capacity are suitable for most applications requiring linear motion. The series commonly used are 28mm series and 42mm series, other series can also be provided if need.

20mm Series Linear Module

LM20 series module, with high precision, can provide up to 5kg of thrust force, suitable for compact and narrow Spaces.



Electrical specification

Prat number	VoltageV	CurrentA	ResistanceΩ	InductionmH	Lead code	StrokeS	LenthL
LM20E1*050-S	2.5	0.5	5.1	1.6	U=0.3048 N=0.6096 AB=1 AC=2 AD=4 AE=8	See below chart	28.2
LM20E1*024-S	5	0.24	20.4	5.0			28.2
LM20E2*132-S	2.5	1.32	1.9	0.75			38.2
LM20E2*065-S	5	0.65	7.7	3			38.2

Out line

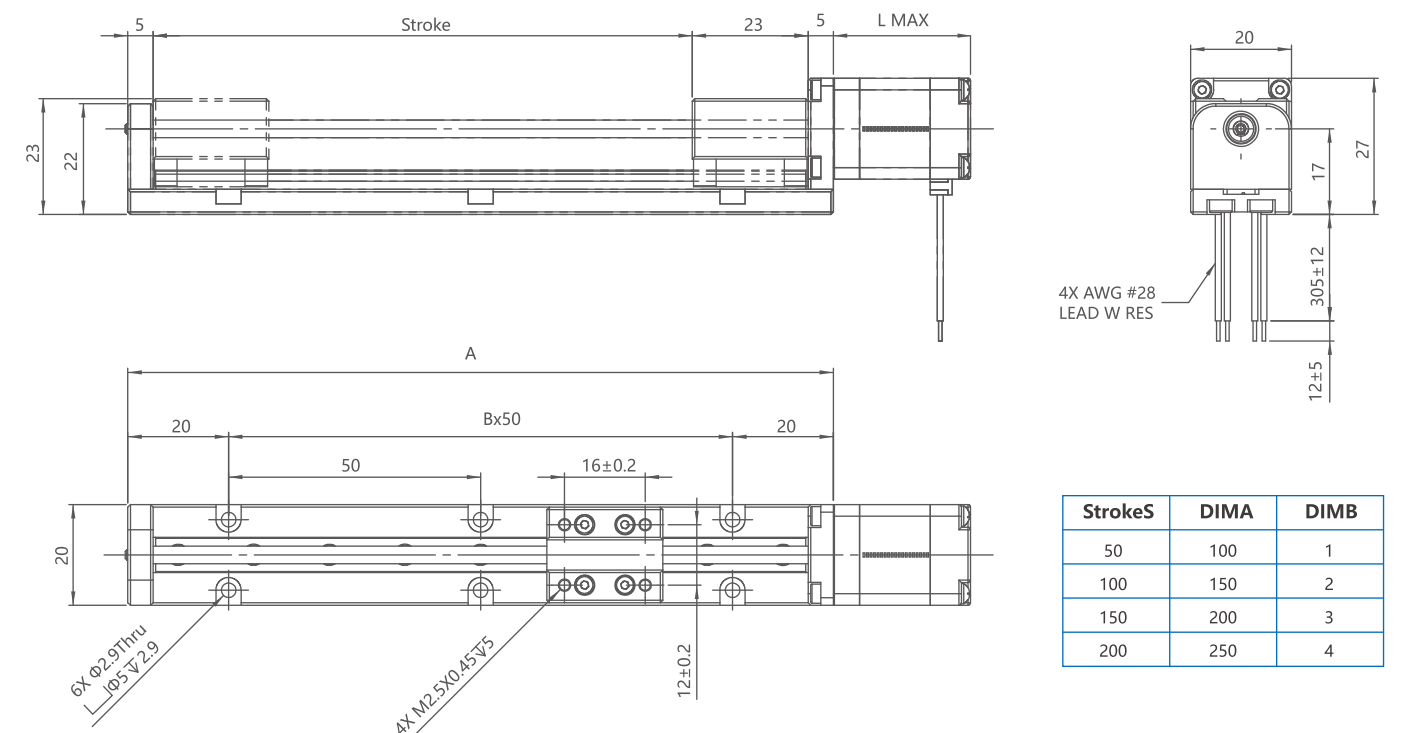

28mm Series Linear Module

LM28 series module, with high precision, can provide up to 10kg of thrust force, suitable for compact and narrow Spaces.



35mm Series Linear Module

LM35 series module, with high precision, can provide up to 20kg of thrust force, suitable for compact and narrow Spaces.



Electrical specification

Prat number	VoltageV	CurrentA	ResistanceΩ	InductionmH	Lead code	StrokeS	LenthL
LM28E1*100-S	2.1	1.0	2.1	1.5	D =0.635 F =1.27 L =2.54 M =5.08 W =10.16	See below chart	32.2
LM28E1*042-S	5	0.42	11.9	8.5			32.2
LM28E2*190-S	2.1	1.9	1.2	1			46
LM28E2*075-S	5	0.75	6.7	5.8			46

Electrical specification

Prat number	VoltageV	CurrentA	ResistanceΩ	InductionmH	Lead code	StrokeS	LenthL
LM35E1*125-S	2.33	1.25	1.86	3	A=1.5875 B=3.175 M=5.08 C=6.35 Y=12.7	See below chart	34.5
LM35E1*057-S	5	0.57	8.8	14			34.5
LM35E2*200-S	2.33	2.0	1.2	1.95			45
LM35E2*091-S	5	0.91	5.5	7.8			45

Out line

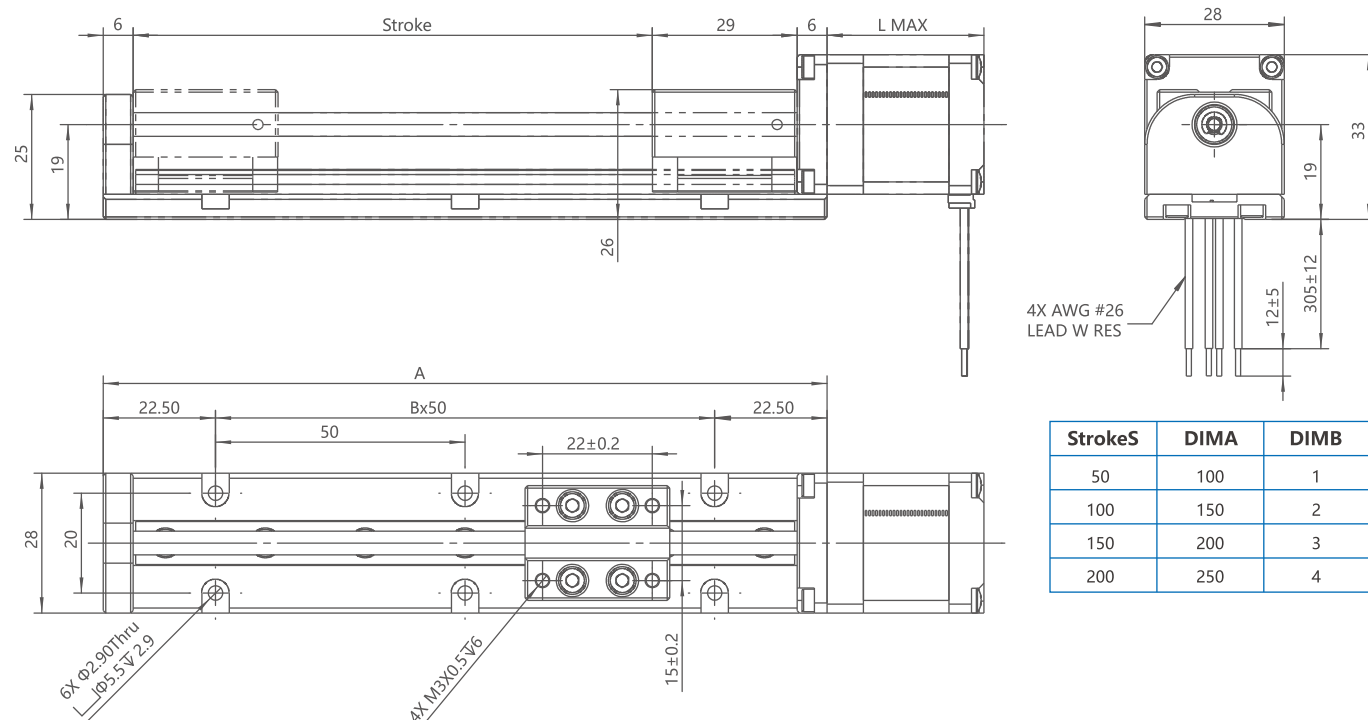

Out line

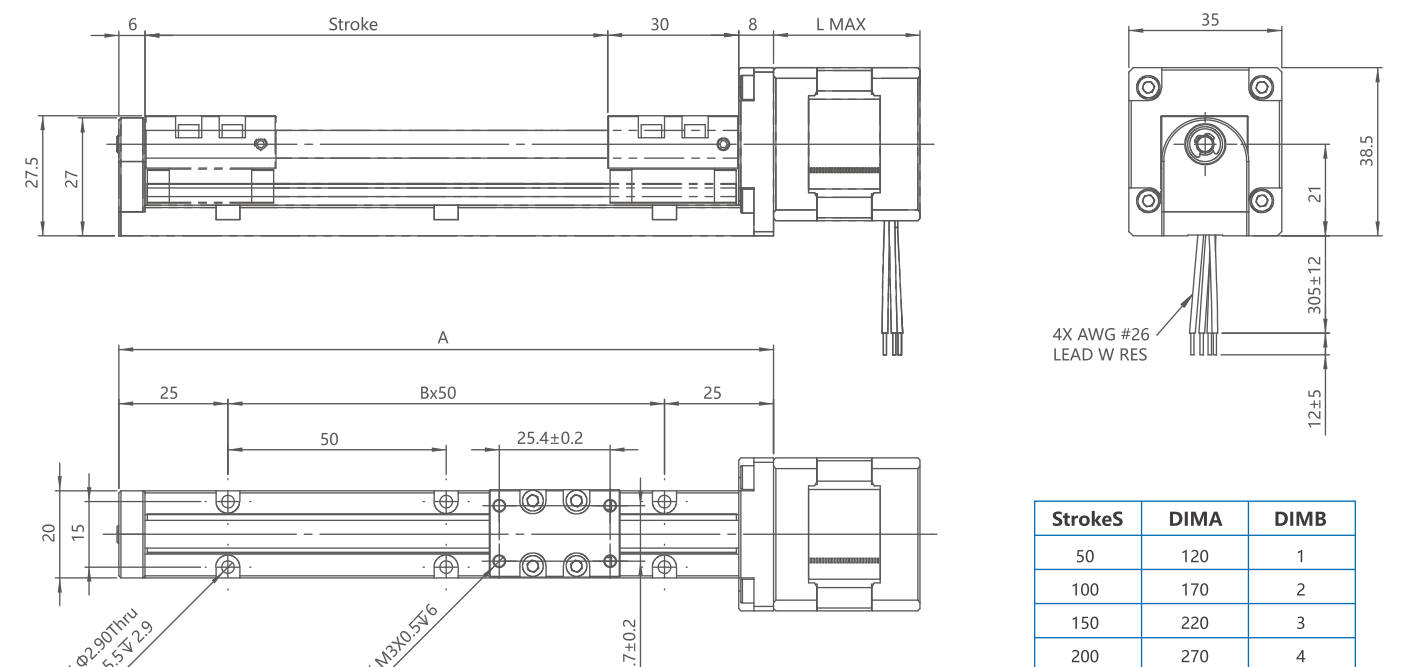

42mm Series Linear Module

LM42 series module, with high precision, can provide up to 30kg of thrust force, suitable for compact and narrow Spaces.



Electrical specification

Prat number	VoltageV	CurrentA	ResistanceΩ	InductionmH	Lead code	StrokeS	LengthL
LM42E1*150-S	2.33	1.5	1.56	1.9	A=1.5875 B=3.175 M=5.08 C=6.35 Y=12.7	See below chart	34
LM42E1*070-S	5	0.7	7.2	9.5			34
LM42E2*260-S	2.33	2.6	0.85	1.1			48
LM42E2*130-S	5	1.3	3.8	7.8			48

Out line

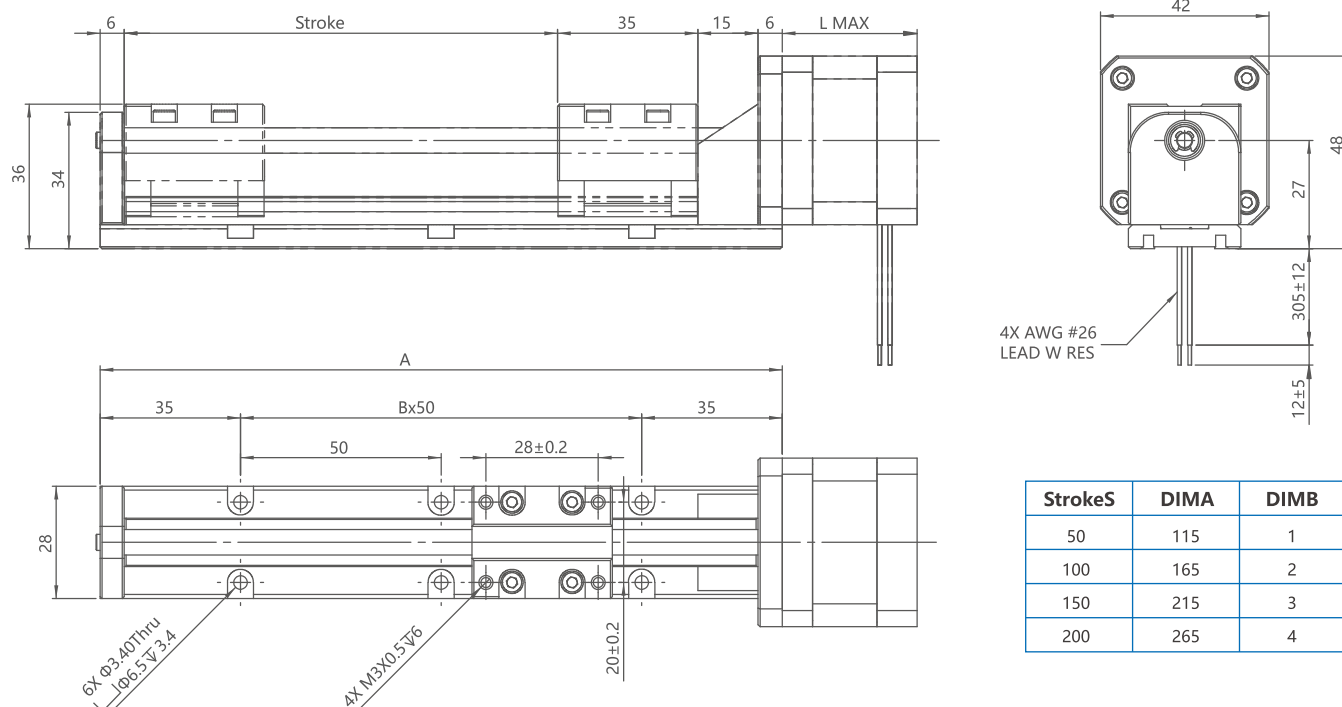

57mm Series Linear Module

LM57 series module, with high precision, can provide up to 90kg of thrust force, suitable for compact and narrow Spaces.



Electrical specification

Prat number	VoltageV	CurrentA	ResistanceΩ	InductionmH	Lead code	StrokeS	LengthL
LM57E1*200-S	3.25	2.0	1.6	3.5	A=1.5875 B=3.175 M=5.08 C=6.35 Y=12.7	See below chart	45
LM57E1*130-S	5	1.3	3.8	15.5			45
LM57E2*330-S	3.25	3.3	0.98	3.2			66
LM57E2*220-S	5	2.2	2.31	7.6			66

Out line

